

Theatrical Fabrics, Custom Curtains & Production Supplies | 2019

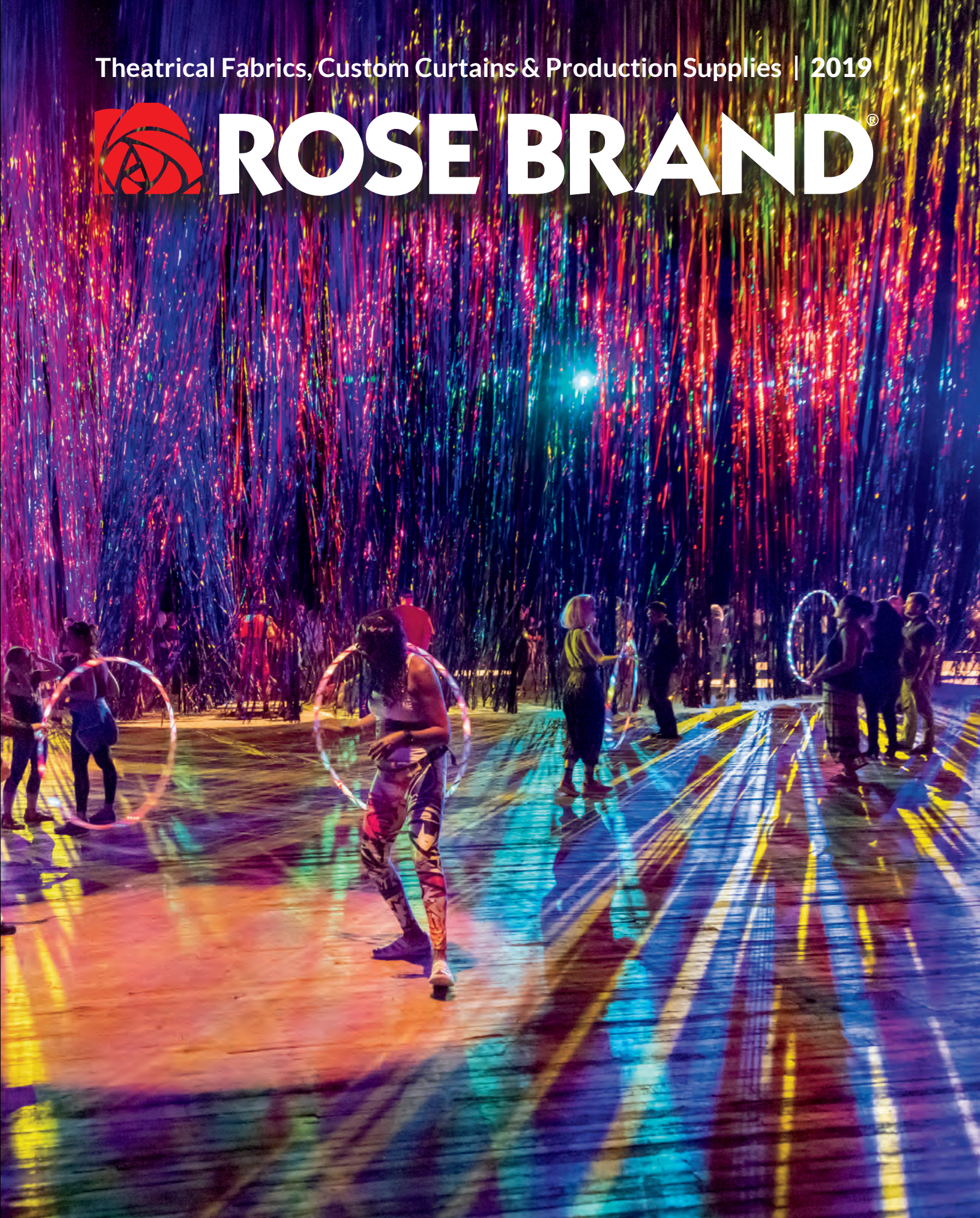

# ROSE BRAND<sup>®</sup>







Product: Precision Cut, 6 Point/3 Thread Sharktooth Scrim, 22 oz Black Encore; The Milwaukee Ballet's *Beauty and the Beast*; Scenic Design: Todd Edward Ivins; The Milwaukee Ballet Scene Shop; Photo: Mark Frohna



# NEW

- P16 DESIGN SPEC BUILD
- P31 ARENA CLOTH
- P38 15 OZ JUVEL CRUSH
- P39 18 OZ JULIET
- P41 SUPER-VEL - WEDGEWOOD
- P56 32'6" IFR MUSLIN
- P70 BARRIER & CLIMBING NETS
- P81 WHITEOUT
- P83 16'5" WHITE VOILE
- P100 ELIZA
- P187 SEAMLESS TRUSS SOCKS
- P188 DIGITAL PRINTING - PRINTHEAD STUDIO
- P195 SEG FRAME SOLUTIONS
- P198 DIGITALLY PRINTED FABRICS BY THE YARD
- P244 SCREEN GOO 2.0
- P253 GLIDE FLOOR
- P255 EXPO GLOSS FLOOR
- P316 INFLATABLE MIRROR SPHERES - GOLD, RED, BLUE
- P336 CHROMA KEY GREEN GAFFER'S TAPE



16

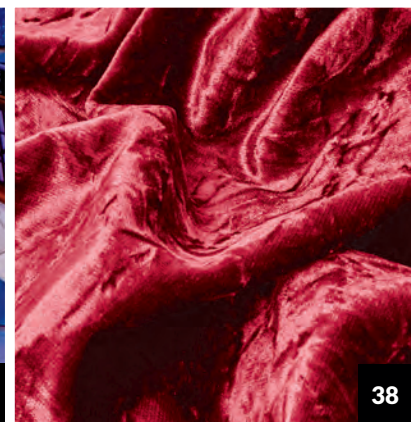

38



39



70



100

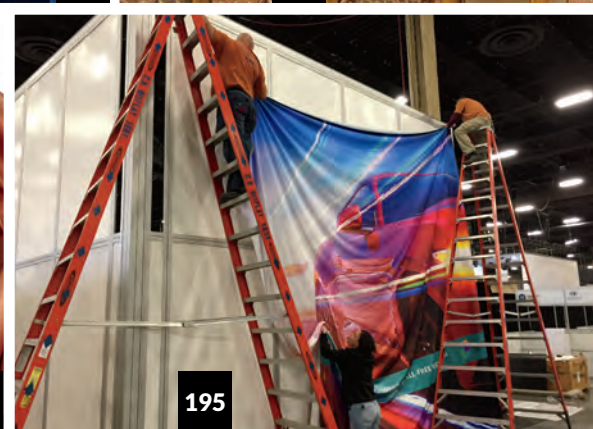

195



188

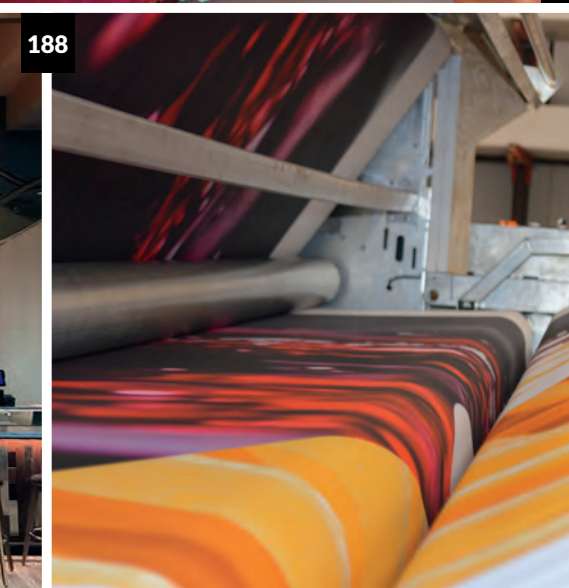

198



## Table of Contents

<b>Introduction</b> <span style="float: right;"><b>6</b></span>	<b>Star Drops &amp; LEDs</b> <span style="float: right;"><b>200</b></span>	<b>Stage Equipment, FXs &amp; Mirrors</b> <span style="float: right;"><b>292</b></span>
Our Vision .....6	ShowLED Classic.....202	The Rose Brand Kabuki System.....294
Made in the USA! .....8	ShowLED Chameleon Star Drops .....204	Snowmachine .....296
Design Spec Build ..... 16	ShowLED Animation Curtains .....206	DMX Scenery Rotator .....297
Portfolio Gallery ..... 18	<b>Pipe &amp; Base</b> <span style="float: right;"><b>208</b></span>	Roll Drums .....298
<b>Fabrics</b> <span style="float: right;"><b>26</b></span>	Pipe & Base 2.0.....210	DMX Winches.....300
Drapery Fabrics ..... 28	Pipe & Base 1.0.....216	SpanFrame™.....304
Black Masking Fabrics ..... 48	<b>Rentals</b> <span style="float: right;"><b>220</b></span>	Glassless Mirrors .....306
Custom Dyable Fabrics ..... 50	Black Masking Curtain Rentals .....222	<b>Scenery Props</b> <span style="float: right;"><b>308</b></span>
Scenic Fabrics ..... 52	Drapery & Swag Rentals .....224	Vacuform Scenic Panels .....310
Stretch Fabrics .....74	LED Star Drops & Animation Curtain..226	Molding Cloth.....312
Specialty Fabrics ..... 76	Metal Beaded Swag Rentals .....226	Stage Props.....314
Event & Display Fabrics..... 82	FXs Rentals.....228	<b>Shop &amp; Production Supplies</b> <span style="float: right;"><b>318</b></span>
Custom Printed Fabrics By The Yard ... 92	Pipe & Base 2.0 Rentals .....228	Scenic Paints .....320
Acoustically Tested Fabrics and Foam...134	Curtain Track Rentals .....229	Adhesives, Primers,
Binder, Swatch Cards .....138	<b>Projection Materials</b> <span style="float: right;"><b>230</b></span>	Base Coats & Coatings.....326
Flame Retardancy.....139	Projection Overview .....232	Decorative Finishes .....328
<b>Custom Stage Curtains &amp; Backdrops</b> <span style="float: right;"><b>140</b></span>	Darknet™ Projections Fabrics .....234	Studio Accessories .....329
Custom Fabric Constructions .....142	Rear Projection Screens .....236	Faux Finishing .....330
Specifying Soft Goods.....144	Front Projection Screens.....238	Theatrical Brushes .....330
Stage Curtain Types.....146	Extra Wide Projection Fabrics .....240	Sprayers .....331
Tassels, Trim & Fringe .....154	Rosco Projection Screens .....241	Flame Retardants .....332
Fire Curtains .....158	Rose Brand Projection Fabrics.....243	Tape .....336
<b>Custom Special Event Sewing</b> <span style="float: right;"><b>160</b></span>	Screen Goo Projection Paint.....244	Prod. Supplies/Shop Supplies .....340
Custom Fabric Constructions .....162	The Rose Brand Stretcher	Prod. Supplies/Sewing Supplies.....342
Precision Cut Fabrics .....164	Frame System .....248	<b>Film &amp; Video Supplies</b> <span style="float: right;"><b>344</b></span>
Custom Jacquard Fabric.....166	<b>Flooring</b> <span style="float: right;"><b>250</b></span>	Masking .....346
Chain Curtains .....168	Stage, Event & Dance Floors.....252	Diffusions .....347
String Curtains .....170	Floor Care.....261	Backdrops & Expendables .....348
Metal Beaded Curtains .....174	Event Carpet .....262	Keying .....349
Rain Curtains.....176	Lux Event Carpet.....264	<b>Discount Store Online</b> <span style="float: right;"><b>350</b></span>
Stretch Shapes .....180	<b>Curtain Track</b> <span style="float: right;"><b>266</b></span>	<b>Index/Ordering Information</b> <span style="float: right;"><b>352</b></span>
<b>Digital Printing</b> <span style="float: right;"><b>188</b></span>	Curtain Track.....268	Index.....354
PrintHead Studio .....190	DMX Track Runner.....269	Staff .....358
Advantages.....192	Triple E Curtain Track.....270	Order Information
Digitally Printed Products .....194	Triple E Curtain Track Motors .....278	and Terms & Conditions.....358
Digital Prints .....196	Touch Panel Controller.....279	
Custom Printed Fabrics By The Yard ..198	ADC Curtain Track.....280	
	ADC Curtain Track Motors & Controller..286	
	ADC Curtain Track Wall Brackets .....287	
	Kirsch Track .....288	
	Rose Brand Custom Bending	
	& Components .....289	
	Stage Rigging & Project	
	Management .....290	



**Rose Brand**  
Company Headquarters  
& Warehouse  
4 Emerson Lane  
Secaucus, NJ 07094  
800-223-1624 | 201-809-1730  
F · 201-809-1851  
automaticdevices.com



**Rose Brand**  
Hardware  
11440 Sheldon Street  
Sun Valley, CA 91352  
800-360-2321  
F · 610-797-4088  
automaticdevices.com

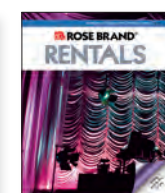

**Rose Brand**  
Rentals  
11440 Sheldon Street  
Sun Valley, CA 91352  
800-360-5056 | 818-505-6290  
F · 818-505-6293

**PrintHead Studio**  
a division of Rose Brand Inc.  
4 Emerson Lane  
Secaucus, NJ 07094  
800-223-1624 x354  
F · 201-809-1851  
printheadstudio.com

**Rose Brand**  
Los Angeles Sales & Warehouse  
11440 Sheldon Street  
Sun Valley, CA 91352  
800-360-5056 | 818-505-6290  
F · 818-505-6293

**Swag Decor, Orlando**  
a Rose Brand company  
3705 Vineland Road  
Orlando, FL 32811  
407-422-3851  
F · 877-455-2851  
SwagDECOR.com

**Rose Brand**  
Canadian Representative  
Technically Yours, Inc.  
288 Judson Street, Unit 5  
Toronto, ON M8Z 5T6  
416-361-9390  
F · 416-361-9745

**Swag Decor, Miami**  
a Rose Brand company  
2203 NW 30th Place, Unit 1  
Pompano Beach, FL 33069  
954-633-4809  
F · 877-455-2851  
SwagDECOR.com



Dear Friends,

Thank you for another great year at Rose Brand. As we enter our 98th year, this new catalog tips the scales at 360 pages, 359 more than when George joined in 1975. We hope it will help you find the best products, services and inspiration for your projects. From staples like rolls of duvetyne and gaff tape to engineering 800' of serpentine curved motorized track, our mission is to help you make your productions happen.

While we're not just fabric anymore it remains our foundation. We have many new offerings in velour, sheers, silks, masking, utility nets and projection substrates.

We are very happy to welcome Automatic Devices Company to the Rose Brand family. Friends and partners for many years, ADC will continue to operate independently, exclusively through its dealer network. Now with stock on the west coast ADC continues to be the industry standard in curtain track and motors.

Last year we launched our Printhead Studio division to concentrate our attention on our fast-growing digital printing services. Like the prints from our new 6 color 16 foot wide fabric printer, the results have been beautiful. We also now offer reasonably priced full color repeat pattern printing by the yard.

Our Swag Decor Division continues to provide the highest quality design and install of event draping and décor in the country. Having a party? Contact Swag.

Thank you so much for your support and friendship. Let's have fun in 2019!

George Jacobstein  
President

Josh Jacobstein  
Executive Vice President

*We Create Your*

**VISION**





# Made in the USA

The Rose Brand® custom sewing operation is  
the largest manufacturing facility  
of its kind in North America.



 **ROSE BRAND**



MADE IN U.S.A.

**NJ 800.223.1624**  
**CA 800.360.5056**  
rosebrand.com



# SERVING THE US ENTERTAINMENT & EVENT MARKETS BETTER AND FASTER THAN ANYONE IN THE WORLD



**THE ROSE BRAND® FAMILY OF COMPANIES:**  
 ROSE BRAND® • SWAG DECOR® • PRINHEAD STUDIO™ • AUTOMATIC DEVICES COMPANY®



INDUSTRIES & ORGANIZATIONS SERVED
THEATRE
EVENTS
SCHOOLS & UNIVERSITIES
SCENE SHOPS
HOUSES OF WORSHIP
TOURING PRODUCTIONS
FILM & VIDEO
THEME PARKS
MUSEUMS
TRADE SHOWS
SPORTS VENUES
EXHIBITS
ARCHITECTURAL ENVIRONMENTS
CONCERTS
VISUAL MERCHANDISING
DANCE
HAUNTED HOUSES
ART INSTALLATIONS

- 1921** Rose Brand Opens its Doors Selling Rags on the Lower East Side of Manhattan.
- 1970** Adds Theatrical Fabrics to Product Offering; Custom Sewing Begins.
- 1986** Publishes First Rose Brand Product Catalog.
- 1995** Rose Brand West Facility Opens in LA.
- 2004** Rose Brand West Outgrows its Facility and Moves to a Bigger Space.
- 2007** East Coast Operations Move to Secaucus, NJ. Facility Space Doubles.



## THE ROSE BRAND FAMILY OF COMPANIES

<b>400+</b> EMPLOYEES	<b>9</b> SALES OFFICES	<b>7</b> WAREHOUSES	<b>4</b> FACTORIES
--------------------------	---------------------------	------------------------	-----------------------



**TALK TO A REP 8:30 AM – 8 PM EASTERN, GET TECHNICAL INFO & BUY ON THE WEB 24X7**

**ROSE BRAND NY/NJ HOURS:** 8:30 AM – 5:00 PM EASTERN  
**ROSE BRAND L.A. HOURS:** 8:30 AM – 5:00 PM PACIFIC  
**PRINHEAD STUDIO HOURS:** 8:30 AM – 5:00 PM EASTERN  
**SWAG DECOR HOURS:** 8:30 AM – 5:00 PM EASTERN  
**ADC HOURS:** 8:00 AM – 5:00 PM EASTERN

OVER  
**15,000**  
SKUS OF  
PRODUCTS

READY FOR SAME DAY SHIPPING

LANGUAGES SPOKEN		
SPANISH	ENGLISH	PORTUGUESE
ARABIC	ITALIAN	JAPANESE
POLISH	CANTONESE	VIETNAMESE
FRENCH	ASHANTI TWI	YIDDISH
HINDI	MANDARIN	HEBREW

NATIVE COUNTRIES		
ARGENTINA	BELIZE	CHINA
COLOMBIA	CUBA	DOMINICAN REPUBLIC
ECUADOR	EL SALVADOR	GHANA
GUATEMALA	GUINEA	GUYANA
HONDURAS	INDIA	MEXICO
NICARAGUA	PERU	CANADA
ST. LUCIA	UNITED STATES	VIETNAM

- 2013** Publishes First Hardware Catalog.
- 2015** NJ Facility Expands by 42,000 Sq Ft. George Jacobstein, President, Celebrates 40 Years with Rose Brand.
- 2015** Rose Brand Acquires Swag Decor, Growing the Florida Market for Event and Decor Services.
- 2016** Rose Brand Celebrates 95 Years of Business.
- 2017** Rose Brand West Again Outgrows its Space and Moves to an Even Larger Facility. Creates Printhead Studio Digital Printing.
- 2018** Acquires Automatic Devices Company.







**We help make stage & event productions more beautiful, more impactful, and much easier to produce. And we do it really FAST!**

### **Largest Sewing Facility in the Industry**

The largest sewing operation of its kind in North America is also the fastest and most experienced. We manufacture more picture-perfect drapery and scenic elements than anyone in the western hemisphere, in 72,000 sq ft of sewing, cutting and layout space, across our East and West Coast facilities.

### **Deepest Inventory**

"In-stock!" We're proud to say those words repeatedly, every day. We've been in the business for so long that we can anticipate most of your fabric, production hardware, and production supply needs. So most of these products are available for same day shipping. We also handle custom curtain and digital printing orders quickly, since most of the time we'll have your selected fabric in stock and we manufacture custom products in-house.



### **Custom Fabrication**

Trust us to deliver expert guidance, workmanship, favorable pricing, and the fastest turnaround time in the industry on custom soft goods. Custom soft goods include curtains, backdrops, and other scenic, event and decorative elements. Our customers range from experts to novices, from the smallest venues to the grandest stages: Broadway theatres, The Academy Awards, arenas, movie sets, churches, museums, college theatres, high school auditoriums, gyms, cafeterias, restaurants, and more.

### **Drapery Design Services**

Many of our clients come to us with designs in-hand. For those who don't, we offer expert design services. Whether you're looking for an ornate main curtain or something more modest, our creative and technical teams work together to design curtains that are as beautiful to see, as they are practical to manufacture and install.

### **Technical Consultation and Engineering:**

We offer Stage Rigging and Technical Project Management services for the design and installation of any curtain, curtain track, or rigging solution. We'll direct, teach & supervise your crew, or bring in our own, depending on your needs. Our network of partners enables us to support clients nationwide.





## Digital Printing

Our Printhead Studio division features 16' high seamless printing in-house, using the most advanced digital direct dye printing technology in the industry. We go beyond the standard 4-color printing to a phenomenal 6-color CMYK+OV process for unbeatable color richness. Our soft fabric folds for compact, inexpensive shipping that stretches to install easily.

We're experts at everything from small banners to enormous backlit fabric translights, to gorgeous floors. Just tell us your objectives, and we'll guide you every step of the way.



## Rentals

Take the stress out of renting curtains, LED drapes and supporting hardware for your events by using our best-in-class rental services. Rose Brand Rentals offers:

- Largest inventory of rental curtains and event drapery in the industry.
- Fast turnaround on orders
- Items checked for perfect condition before shipping
- Items labeled for exact placement in your venue to speed load-in and lower setup costs



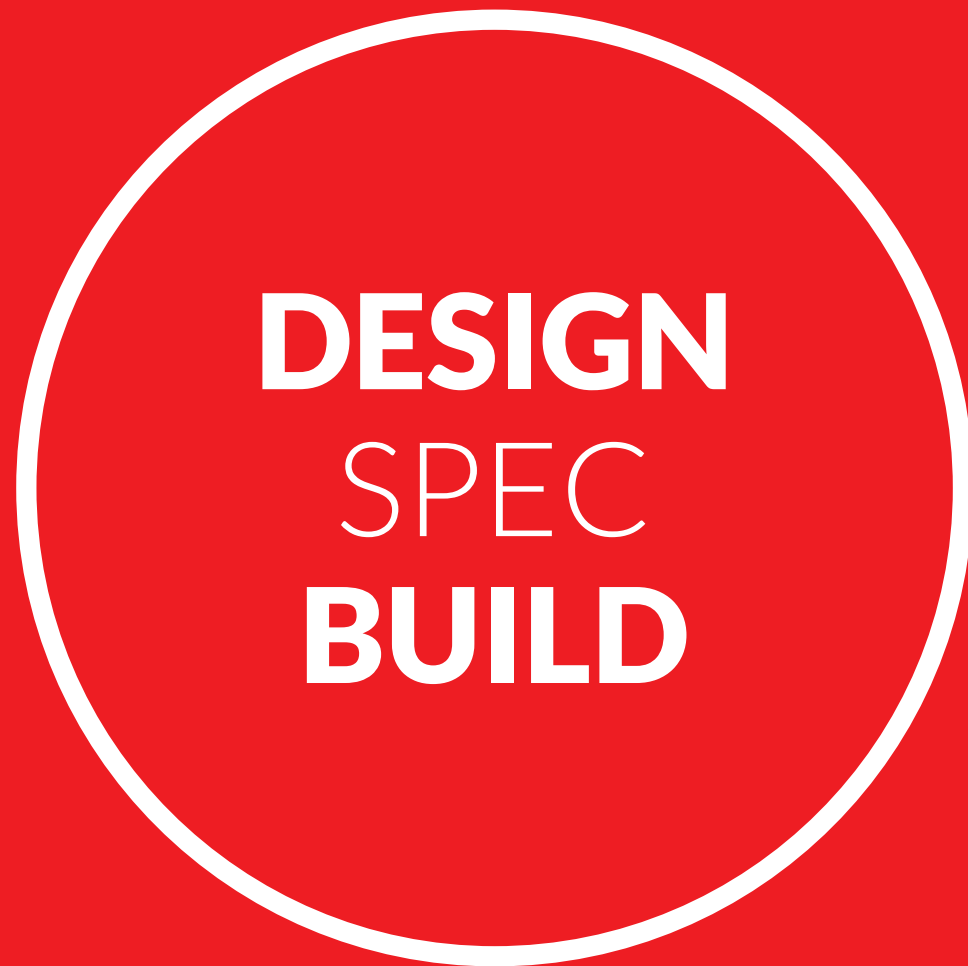

# *Design Specify & Build Services*

We offer design consultation, specification and build services for virtually any production, event or architectural environment that involves fabric and hardware components. We can help you at any or all points in the design, spec and build process.

## **Design**

Whether you're asking us to design your project, or designing on your own, we're happy to consult with you in the earliest phases of concept creation so that we can insure designs that are as practical as they are aesthetic. Practical considerations might include appropriate material choices, safety regulations, budget, timing, maintenance, longevity, ease of installation, etc. Designs usually begin as sketches, which are then translated into technical drawings once they're approved by the customer.

## **Specification**

Once a design has been translated into a technical drawing, the process of specification has begun. Specifications may include products, dimensions, as well as instructions for seaming, fullness, cutting, bending, printing, finishing, installation and more.

## **Build**

Our "builders" include cutters, sewers, scenic artists, metal specialists, carpenters, electricians, and technical project managers with ETCP certification. New, innovative or technically complex projects often proceed with prototypes prior to the final build. Depending on complexity and size, projects may be pre-installed in our warehouse facility to insure minimal issues during load-in at your venue.

## **Projects**

The following pages show just a few examples of our recent work in the design, specification and build areas. Contact us about your own project. Our experience is vast and our knowledge is deep.



# MAIN CURTAIN

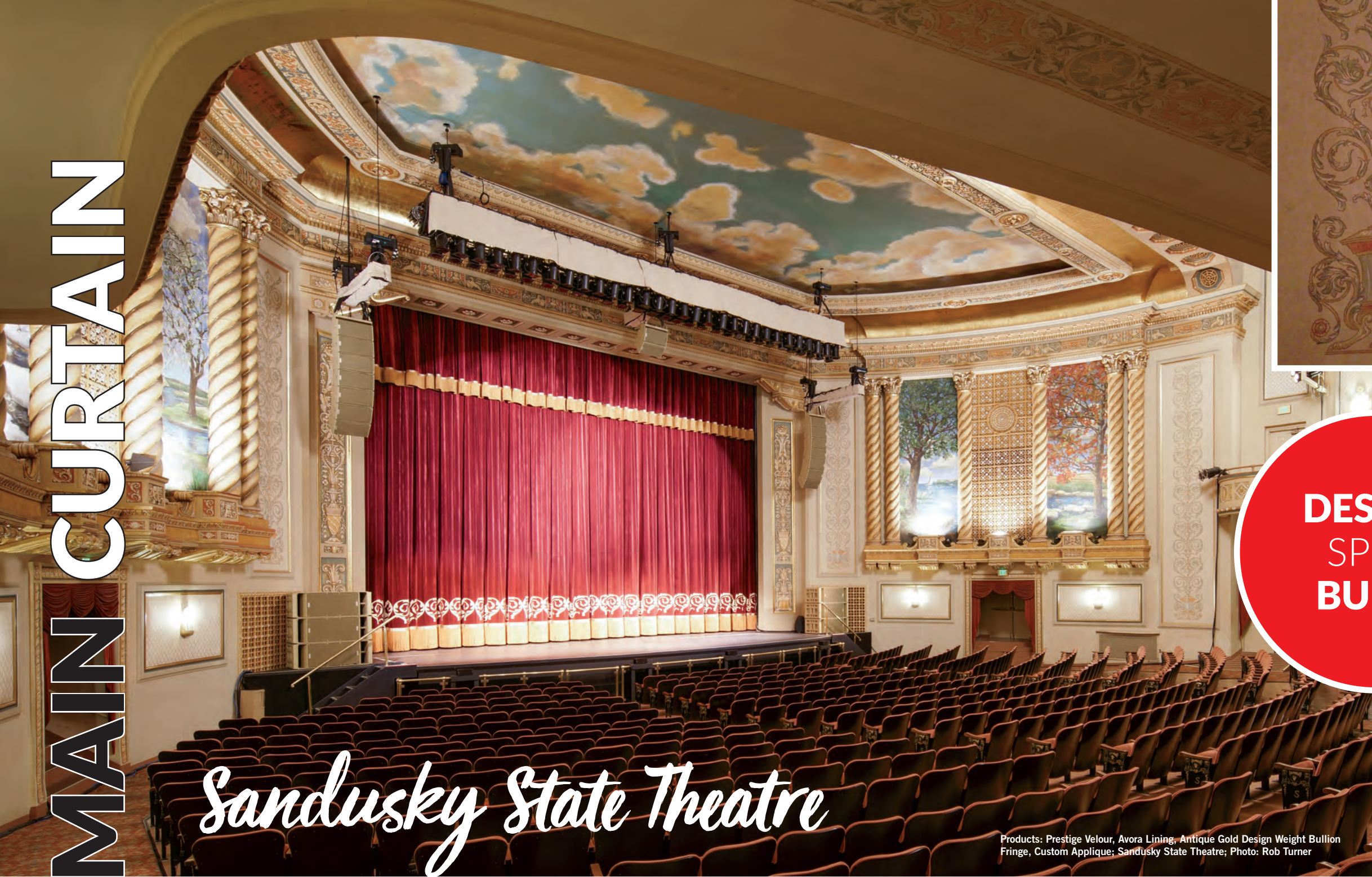

**DESIGN  
SPEC  
BUILD**

## *Sandusky State Theatre*

Products: Prestige Velour, Avora Lining, Antique Gold Design Weight Bullion Fringe, Custom Applique; Sandusky State Theatre; Photo: Rob Turner

The Sandusky State Theatre, a historical landmark in Ohio, wanted to transform the main stage of the 90-year-old theatre with new curtains designed to bring the space to life and capture the theatre's rich heritage.

Inspired by photos of the theatre's interior architecture, we designed a curtain that incorporated a prominent curvilinear architectural detail on the walls near the stage.

Replicating the intricate pattern at the bottom of a pleated drape presented an interesting design challenge. How do

you get the pattern applique to display appropriately, despite the fullness sewn into the curtain? Our technical team developed several renderings of the project, and then several physical mock-ups, before obtaining final design approval.

Rose Brand Inc. led the customer through the entire design, specification and build of this project. The job was a collaborative effort between the client and our sales team, design team, technical department, sewing shop and senior management. It's a great example of how Rose Brand provides turnkey solutions to custom needs.





# ARC

# LIGHTING SURFACE



Concert Tour

DESIGN  
SPEC  
BUILD

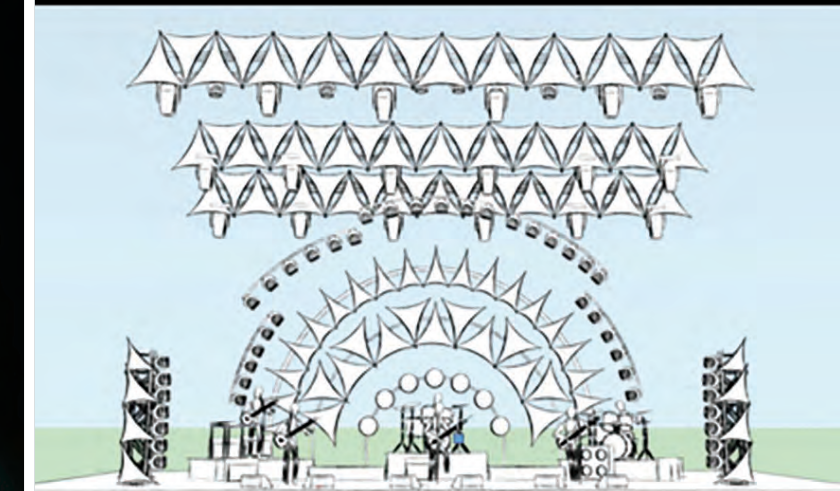

Customer Drawing

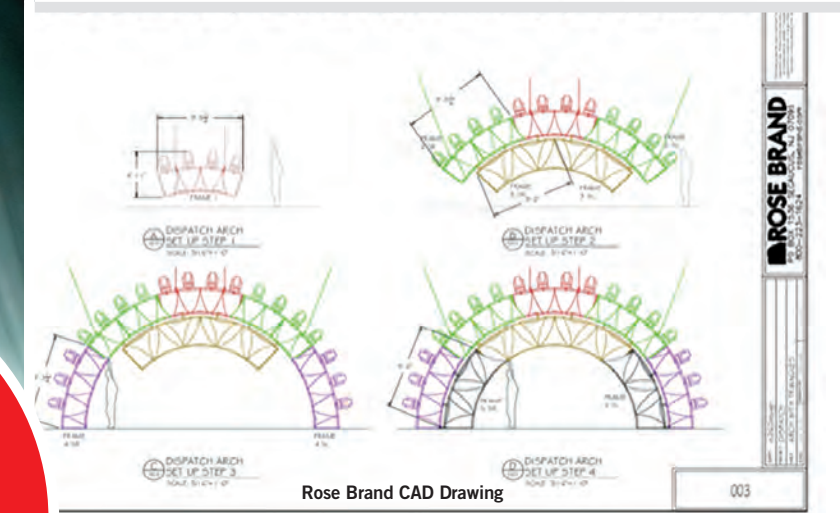

Rose Brand CAD Drawing



Working on the design for the Dispatch Summer tour, lighting designer Marc Janowitz asked us to create a floating visual surface for the tour's lighting design. Janowitz's concept relied on several rings of triangular stretch shapes floating in an arc 30ft in diameter, onto which he would project colored and textured lighting. Since the tour locations were mostly outdoors, concerns for wind and the elements had to be taken into account, as well as the typical fast, easy, tool-free load-in required by music touring in general.

We produced both the stretch shapes and the arched, modular frame to house them. Our frame design consisted of interlocking units held together with détente pins, which could be hung from truss or pipe in short order. Each subsequent frame stiffened the overall structure as it was assembled. The triangular stretch shapes shipped attached to each frame, to speed up load-ins, but could easily be replaced in case of dirt or damage.

Printhead Studio, our internal digital printing division, provided several hundred feet of printed truss borders

to extend the lighting visuals. The prints had a Velcro™ tear-away webbing in case of high winds.

In the end, Rose Brand provided the custom sized stretch shapes, as well as the technical design, fabrication, and digital printing necessary to bring the design to life.

Product: White Tendo Stretch Shapes, Technical Design and Fabrication of Aluminum Touring Arch; *Dispatch Summer Tour*; Designer: Marc Janowitz at E26 Design; Photo: Michael Smith



# FLOORING & BACKDROP

DIGITALLY PRINTED

*NBC Sports*

We worked with our friends at Black Walnut to specify and build printed flooring, ceiling and backdrop tiles for the NBC Sports Winter Olympics studio. Concept and design planning began years in advance of the Olympic games. The Olympic studio's graphically intense scenic elements resulted from months of brainstorming and product sampling. Blackwalnut and NBC Sports selected Rose Brand printed "Impact" floor for the Winter games' studio because it installed much more quickly and

provided greater flexibility than the tiles used in prior years. For example, it allowed Black Walnut to quickly adjust their design on-site in order to create the jagged rock reveals in the fabricated deck.

The ceiling panels that filled in the deconstructed Geodesic dome shape were more challenging. The limited load bearing capacity of the studio infrastructure and the geometry of the 7th Order dome required

Product: Printed Impact Floor, 6 oz. Printed Poplin; NBC Sports Pyeongchang 2018 Winter Olympics; Venue: International Broadcast Center, Pyeongchang, South Korea; Designer: Bryan Higgason, HD Studio; Scene Shop: blackwalnut; Photo: Jacob Gendelman

a substrate with special features. It needed to be oversized yet lightweight, and it needed to look fantastic when printed, seamed and front lit by the LEDs embedded in the dome's frame. We recommended gatorboard for the geometric ceiling tiles and SAV for the marbled backdrop pieces. As our client at Black Walnut said, "The results speak for themselves."

DESIGN  
SPEC  
BUILD





**DESIGN  
SPEC  
BUILD**

# It's Raining Curtains

## PARK AVENUE ARMORY

Products: Rain Curtains; Custom Curved Track and Installation Services; *The Let Go* by Nick Cave at Park Avenue Armory, June 2018; Director of Production: Paul King; Photo by James Prinz Photography. Courtesy of the artist and Jack Shainman Gallery, New York.

At times a magnificent work of performance art; at other times an immersive, interactive art installation playground. That was artist Nick Cave's masterpiece, "The Let Go," which played to sellout crowds at the Park Ave Armory in NYC.

Rose Brand's biggest challenge was how to engineer the 800' loop of serpentine, compound curved track that moved massive multi-layer Rain Curtains continuously

throughout the Armory's huge space. Dancers, hula hoopers, DJs, actors, and the public at large took their turns playing, performing, or expressing whatever emotions they felt within the flowing strips of curtains set to music.

Do you have a custom project that demands a unique solution? *Bring it!*

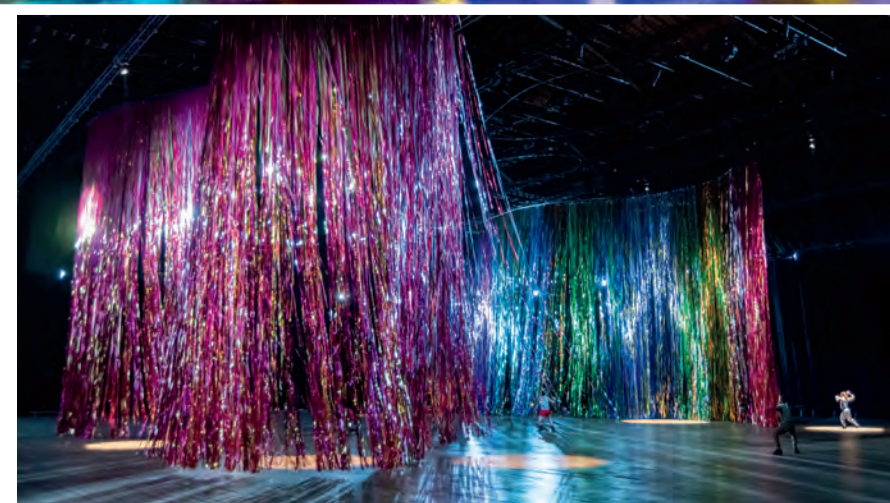



# Fabrics

- Drapery Fabrics** ..... 28
  - Synthetic Velour ..... 29
  - Cotton Velour ..... 42
  - Lining Fabric ..... 45
  - Commando Cloth & Duvetyn ..... 46
- Masking Fabrics** ..... 48
- Custom Dyable Fabrics** ..... 50
- Scenic Fabrics** ..... 52
  - Canvas ..... 53
  - Muslin ..... 54
  - Full Size Netting Comparison ..... 58
  - Scrim & Leno ..... 60
  - Bobbinette ..... 62
  - Netting & Gauze ..... 63
  - Burlap & Textured ..... 67
  - Textured ..... 68
- Barrier & Climbing Nets** ..... 70
- Stretch Fabrics** ..... 74
- Specialty Fabrics** ..... 76
- Event & Display Fabrics** ..... 82
  - Sheer ..... 83
- Custom Printed Fabrics By The Yard** ..... 92
  - Silk ..... 95
  - Satin ..... 102
  - Metallic ..... 112
  - Linen & Gauze ..... 121
  - Textured & Matte ..... 124
  - Expo & Outdoor ..... 130
- Acoustically Tested Fabrics & Foam** ..... 134
- Binder/Swatch Cards** ..... 138
- Flame Retardancy** ..... 139

Look for these indicators for  
Volume Pricing on our Most  
Popular Fabrics

300+ Yards

500+ Yards

**VOLUME DISCOUNT**

\*Must be Purchased in Full Roll/Piece Increments.



- Fabrics
- Black Masking
- Custom Stage Curtains & Backdrops
- Custom Special Event Sewing
- Digital Printing
- LED Star Drops
- Pipe & Base
- Rentals
- Projection Materials
- Flooring
- Curtain Track
- Stage Equipment, FXs & Mirrors
- DMX Winches
- Scenery Props
- Shop & Production Supplies
- Tape
- Film & Video Supplies
- Index





Rose Brand has the widest and deepest stock of **Flame Retardant** and **Inherently Flame Retardant** velour in the industry. It ranges from lightweight velour and velvet for pipe & drape and decorative swags; to medium and heavyweight velour for main drapes, stage masking and acoustical panels.

Product: 25 oz. Prestige Velour; *Red Velvet*, Chicago Shakespeare Theater, Courtyard Theater; Director: Gary Griffin; Scenic Designer: Scott Davis; Scene Shop: Scenic Solutions and Ravenswood Scenic Studios Inc.; Photo: Liz Lauren

Synthetic Velour

32 OZ. ROYALE

**Inherently Flame Retardant.** This sumptuous matte velour has great depth of color and a plush feel. The Black absorbs light like a cotton velour with all the advantages of an **IFR** synthetic. This Super Weight velour is opaque and sound absorbing making it an excellent choice for new high-end installations or historical replacements. Available by special order in custom colors or any of the cotton velour colors on page 42. Requires approximate 3 week lead time and minimum 200 yard order.

Roll = Approx. 50-60 yds.

	Price Per Yard	
	Cut	Full Roll
54" <b>IFR</b>	N.A.	31.20



32 OZ. IMPERIAL

**Inherently Flame Retardant.** This luxurious velour has the rich satiny look of velvet. Use it to create the most opulent curtains with all the durability and benefits of an **IFR** synthetic. This Super Weight velour is moisture resistant, making it ideal for regions with high humidity. Available by special order in custom colors or any of the cotton velour colors on page 42. Requires approximate 3 week lead time and minimum 200 yard order.

Roll = Approx. 70-75 yds.

	Price Per Yard	
	Cut	Full Roll
54" <b>IFR</b>	N.A.	28.00

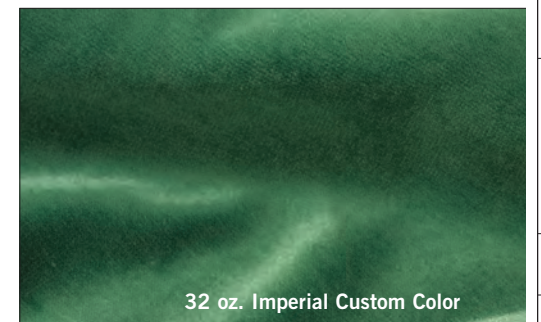



## Synthetic Velour

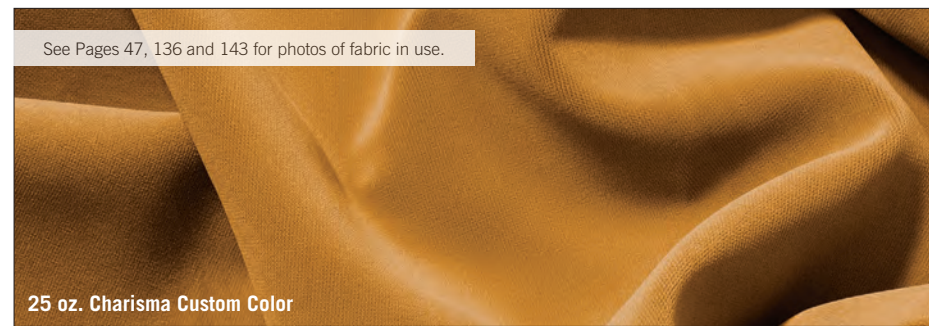

See Pages 47, 136 and 143 for photos of fabric in use.

25 oz. Charisma Custom Color

### 25 OZ. CHARISMA

**Inherently Flame Retardant.** Elegant matte velour with incredible depth of color. Absorbs light like a cotton velour with all the advantages of an IFR synthetic velour. Superior for sound absorbency. Black in stock. Available by special order in custom colors or any of the cotton velour colors on page 42. Colors require approximately 3 week lead time and 200 yard order.

Roll = Approx. 90-110 yds.

	Price Per Yard	
	Cut	Full Roll
54" <b>IFR</b> Black	27.95	21.50
54" <b>IFR</b> Colors	N.A.	21.50

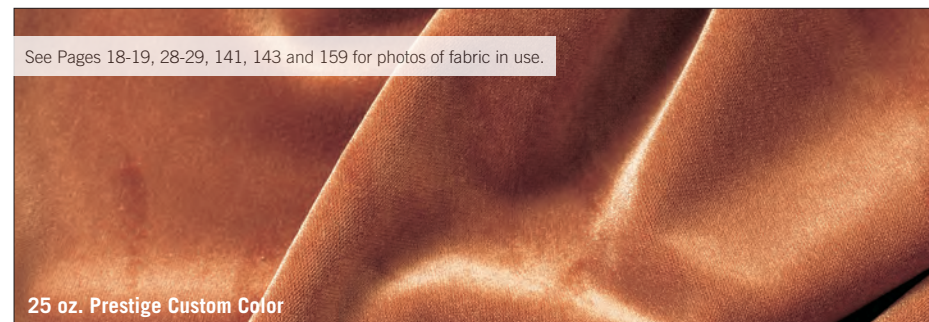

See Pages 18-19, 28-29, 141, 143 and 159 for photos of fabric in use.

25 oz. Prestige Custom Color

### 25 OZ. PRESTIGE

**Inherently Flame Retardant.** Heavy weight. Has the rich, satiny full look of velvet with the durability and moisture resistance of a synthetic. Black in stock. Available by special order in custom colors or any of the cotton velour colors on page 42. Colors require approximately 3 week lead time and minimum 200 yards.

Roll = Approx. 70-80 yds.

	Price Per Yard	
	Cut	Full Roll
54" <b>IFR</b> Black	26.65	20.50
54" <b>IFR</b> Colors	N.A.	20.50

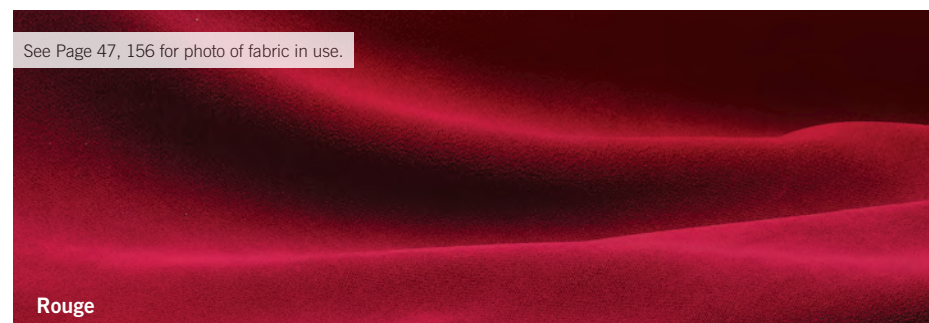

See Page 47, 156 for photo of fabric in use.

Rouge



### Most Popular!

#### 20 OZ. CRESCENT

**Inherently Flame Retardant.** Crescent is an extremely durable medium weight matte velour that is 99% opaque. It has the classic look of cotton velour with all the advantages and versatility of a synthetic. Soft of hand, this exceptional fabric hangs beautifully and can be used for all types of contour curtains, masking panels and grand drapes. All colors in stock and ready to ship. Custom colors – 200 yd. minimum.

Roll = Approx. 90-110 yds.

	Price Per Yard	
	Cut	Full Roll
54" <b>IFR</b>	22.50	17.30

### 16 OZ. CRYSTAL VEL

**Inherently Flame Retardant.** A beautiful jet black or white lightweight velour covered in a brilliant silver metallic treatment. The glittering highlights reflect light magnificently. This brushed polyester velour is nearly opaque, durable and wrinkle resistant. Crystal Vel is ideal for Austrian curtains and swags. Wrinkle resistance makes this fabric wonderful for touring shows as well.

Roll = Approx. 80-85 yds.

	Price Per Yard	
	Cut	Full Roll
60" <b>IFR</b>	23.75	19.00

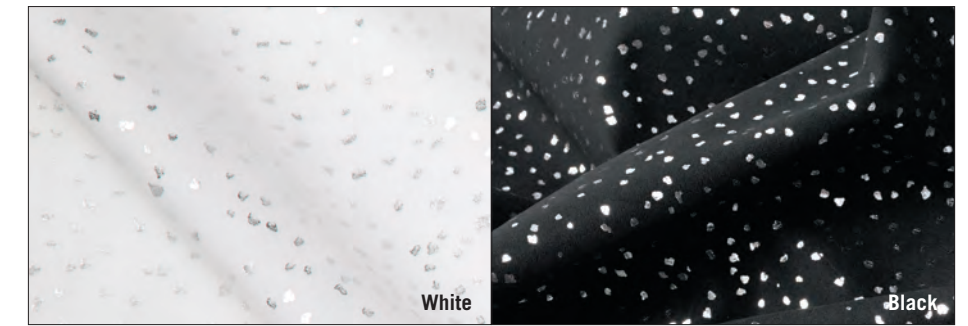

White

Black

### 14 OZ. MAGICIAN

**Inherently Flame Retardant.** The deep black finish on this nearly opaque, lightweight velour makes it an ideal choice for masking when you need an economical IFR velour with great light absorbing properties.

Roll = Approx. 120 yds.

	Price Per Yard	
	Cut	Full Roll
54" <b>IFR</b> Deep Black	19.75	15.80



Deep Black

### ARENA CLOTH

**Inherently Flame Retardant.** Great for arena and bowl reductions. A lightweight but durable brushed fabric, it's 130" width at this price makes it an economical option for coverage of large areas.

Roll size = 100 yds.

	Price Per Yard	
	Cut	Full Roll
130" <b>IFR</b> Black, Grey	29.25	19.50

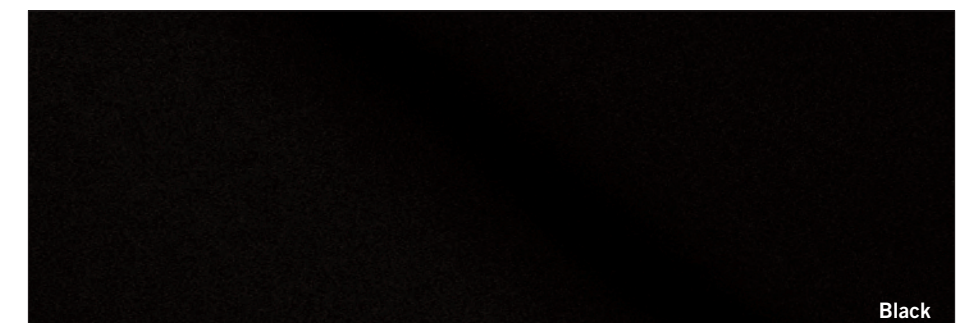

Black

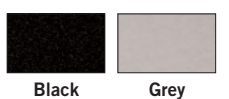





Product: Encore and Erosion Cloth; *The World's Game Show "Harvest of Riches"*, Winstar Worlds Casino; Photo: Mike Foosh

## Synthetic Velour

*Consistent Color from Dye Lot to Dye Lot! All Colors in Stock. Largest Inventory in the Country!*

**Most Popular!**

### 22 OZ. ENCORE™

**Inherently Flame Retardant.** Medium weight brushed 100% polyester. Totally opaque, durable and wrinkle resistant. Ideal for outdoor venues and high humidity climates. 16 colors in stock and ready to ship.

Roll = Approx. 65 yds.

	Price Per Yard	
	Cut	Full Roll
64" <b>IFR</b> Black	22.23	18.50
64" <b>IFR</b> Colors	22.91	19.10

**Most Popular! | Buy or Rent**

### 15 OZ. ENCORE™

**Inherently Flame Retardant.** Lightweight brushed polyester. Drapes beautifully. Ideal for swags and Austrian drapes. 16 colors in stock and ready to ship.

**Also used for our rental stock drapes.**

Roll = Approx. 60 yds.

	Price Per Yard	
	Cut	Full Roll
62" <b>IFR</b> Black	15.94	12.75
62" <b>IFR</b> Colors	17.53	13.50



See Pages 32, 63, 110, 136, 222, 233, 267 and 287 for photos of fabric in use.



Working closely with renowned textile innovator Milliken & Co., Rose Brand helped develop ENCORE™, the most popular synthetic velour in the entertainment industry!

- Fabrics
- Black Masking
- Custom Stage Curtains & Backdrops
- Custom Special Event Sewing
- Digital Printing
- LED Star Drops
- Pipe & Base
- Rentals
- Projection Materials
- Flooring
- Curtain Track
- Stage Equipment, FXs & Mirrors
- DMX Winches
- Scenery Props
- Shop & Production Supplies
- Tape
- Film & Video Supplies
- Index



## Synthetic Velour

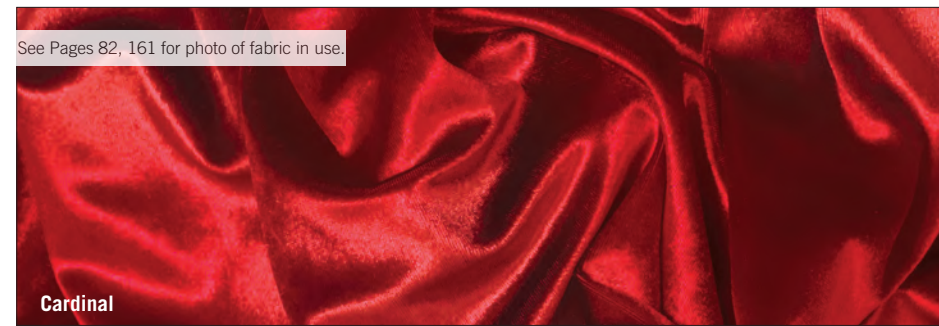

### GLISS VELVET

**Inherently Flame Retardant.** A beautiful lightweight polished polyester velvet that glistens and glows with reflected light. In stock and ready to ship.

Roll = Approx. 50-65 yds.

	Price Per Yard	
	Cut	Full Roll
57" <b>IFR</b>	16.90	13.00

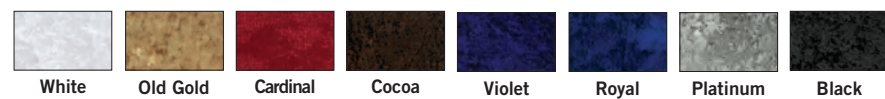
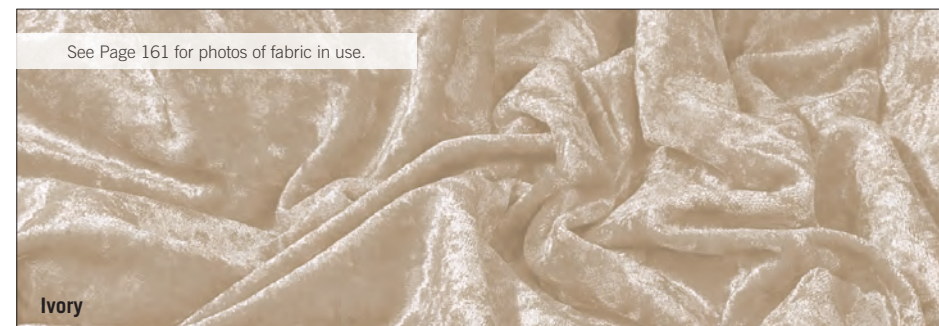

Most Popular! | Buy or Rent

### GLISS PANNÉ VELVET

**Inherently Flame Retardant.** A lustrous lightweight polished polyester velvet finished with the classic panné texture. In stock and ready to ship.

Roll = Approx. 55-65 yds.

	Price Per Yard	
	Cut	Full Roll
56" <b>IFR</b>	18.93	14.55



### 20 OZ. EMPRESS

**Inherently Flame Retardant.** Lightweight, high-napped synthetic velour with a silky finish. Great for draping and Austrian curtains. Available by special order in custom colors or any of the cotton velour colors on page 42. Colors require approximate 3 week lead time and minimum 200 yard order.

Roll = Approx. 44-55 yds.

	Price Per Yard	
	Cut	Full Roll
54" <b>IFR</b> Black	N.A.	17.30
54" <b>IFR</b> Colors	N.A.	19.00

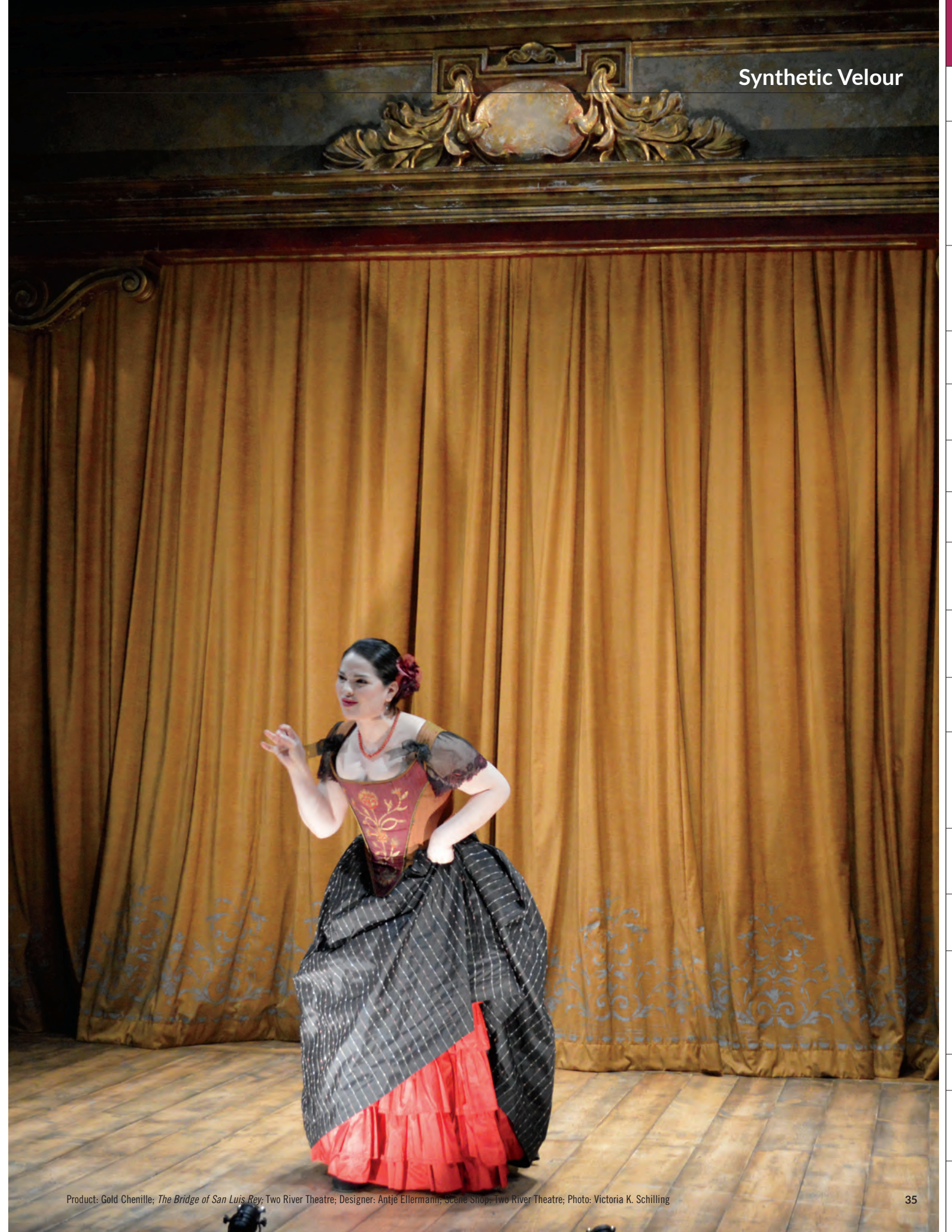

## Synthetic Velour

- Fabrics
- Black Masking
- Custom Stage Curtains & Backdrops
- Custom Special Event Sewing
- Digital Printing
- LED Star Drops
- Pipe & Base
- Rentals
- Projection Materials
- Flooring
- Curtain Track
- Stage Equipment, FXs & Mirrors
- DMX Winches
- Scenery Props
- Shop & Production Supplies
- Tape
- Film & Video Supplies
- Index





Products: Athena, Custom Sewing; The Sarasota Ballet in George Balanchine's *Jewels*; Photo: Frank Atura

## Synthetic Velour

### 23 OZ. ATHENA

**Inherently Flame Retardant.** With the same features as the lighter weight Athena, the 23 oz. is a great choice for large scale applications that require heavy duty curtains.

Roll = Approx. 65-75 yds.

	Price Per Yard		
	Cut	Full Roll	500+ Yds*
60" <b>IFR</b>	25.50	17.00	15.00

#### VOLUME DISCOUNT

\*Must be Purchased in Full Roll/Piece Increments.

### Most Popular!

### 16 OZ. ATHENA

**Inherently Flame Retardant.** It is easy to mistake this lightweight durable fabric for a much heavier velour. Athena is totally opaque and its chamois brushed surface creates a smooth luxurious look. The soft hand is great for Austrian curtains, Swags and other draping projects. Wrinkle resistant construction makes it ideal for touring and masking. In stock and ready to ship.

Roll = Approx. 85-95 yds.

	Price Per Yard		
	Cut	Full Roll	500+ Yds*
60" <b>IFR</b>	16.50	11.00	9.50

#### VOLUME DISCOUNT

\*Must be Purchased in Full Roll/Piece Increments.



- Fabrics
- Black Masking
- Custom Stage Curtains & Backdrops
- Custom Special Event Sewing
- Digital Printing
- LED Star Drops
- Pipe & Base
- Rentals
- Projection Materials
- Flooring
- Curtain Track
- Stage Equipment, FXs & Mirrors
- DMX Winches
- Scenery Props
- Shop & Production Supplies
- Tape
- Film & Video Supplies
- Index



Synthetic Velour

# Juvel Crush

## 15 OZ. JUVEL CRUSH

**Inherently Flame Retardant.** A radiant medium weight IFR crushed velvet that can play a period role and also works in contemporary settings.

Roll = Approx. 60 yds.

54" IFR	Price Per Yard	
	Cut	Full Roll
	19.60	14.00

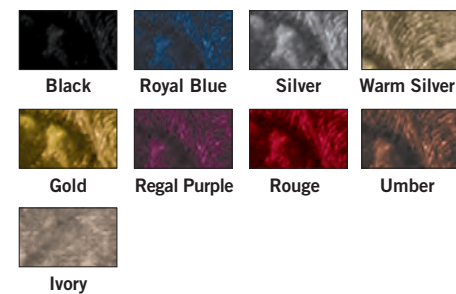

## 18 OZ. JULIET

**Inherently Flame Retardant.** This lustrous medium weight IFR velour has the look of high end interior fabric at a price that makes it practical for large scale drapery treatments.

Roll = Approx. 50 yds.

54" IFR	Price Per Yard	
	Cut	Full Roll
	18.90	13.50

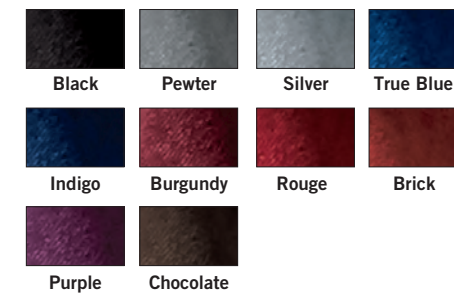

Synthetic Velour

# Juliet

- Fabrics
- Black Masking
- Custom Stage Curtains & Backdrops
- Custom Special Event Sewing
- Digital Printing
- LED Star Drops
- Pipe & Base
- Rentals
- Projection Materials
- Flooring
- Curtain Track
- Stage Equipment, FXs & Mirrors
- DMX Winches
- Scenery Props
- Shop & Production Supplies
- Tape
- Film & Video Supplies
- Index



## Synthetic Velour

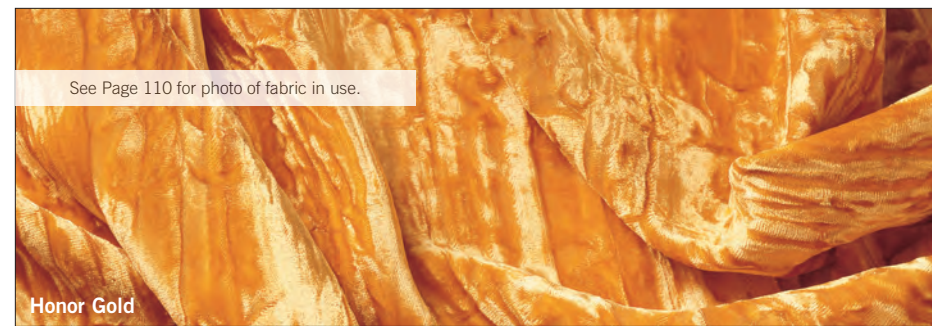

See Page 110 for photo of fabric in use.

Honor Gold

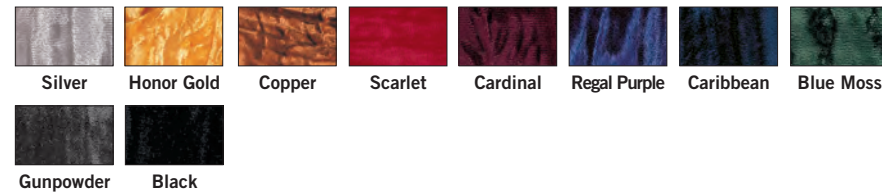

### 10 OZ. CRUSHED VELVET

**Flame Retardant.** Medium weight, synthetic velvet, 100% rayon, captures light for a wonderful effect. In stock and ready to ship.

Roll = Approx. 20-30 yds.

53" FR	Price Per Yard	
	Cut	Full Roll
	23.97	18.45



See Page 35 for photo of fabric in use.

Green Apple

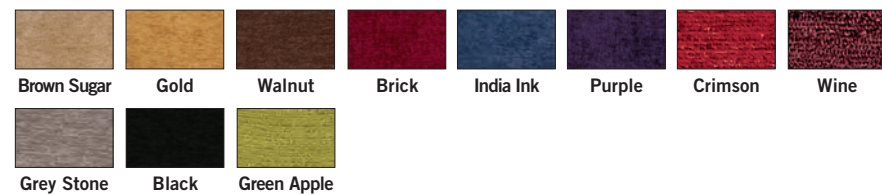

### 16 OZ. CHENILLE

**Inherently Flame Retardant.** 100% polyester. The richness of velour with varied texture in a lightweight, contemporary drapery fabric. Perfect for swags, decorative treatments and Austrian curtains. In stock and ready to ship.

Roll = Approx. 55-70 yds.

54" IFR	Price Per Yard	
	Cut	Full Roll
	16.90	13.00



Cornflower



### 13 OZ. APOLLO

**Inherently Flame Retardant.** Lightweight and virtually opaque. This beautiful synthetic velour has the look and feel of high end velvets many times its price. Vibrant saturated colors and a soft hand for draping. Custom colors available. In stock and ready to ship.

Roll = Approx. 125-150 yds.

54" IFR	Price Per Yard	
	Cut	Full Roll
	17.95	13.80

### 12 OZ. BRAVA

**Inherently Flame Retardant.** The best possible value in an opaque, lightweight lightly, brushed masking fabric. Drapes beautifully for decorative treatments. In stock and ready to ship.

Roll = Approx. 80-100 yds.

54" IFR	Price Per Yard	
	Cut	Full Roll
	11.75	9.00

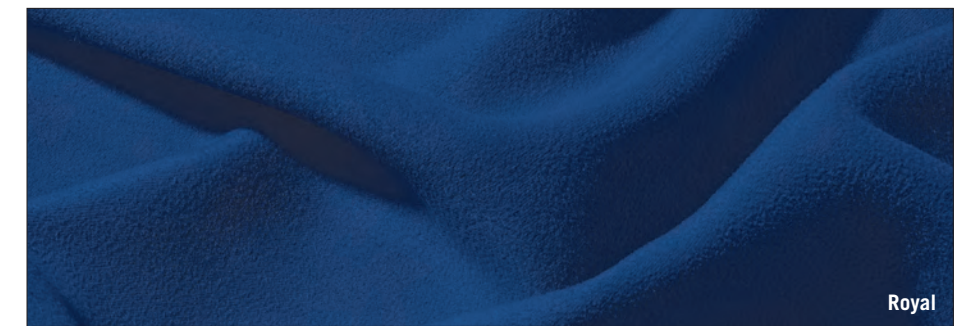

Royal



Buy or Rent

### 8 OZ. SUPER-VEL®

**Inherently Flame Retardant.** Our most popular ultra lightweight, brushed velour! In stock and ready to ship.

Roll = Approx. 100 yds.

60" IFR	Price Per Yard	
	Cut	Full Roll
	10.92	8.40

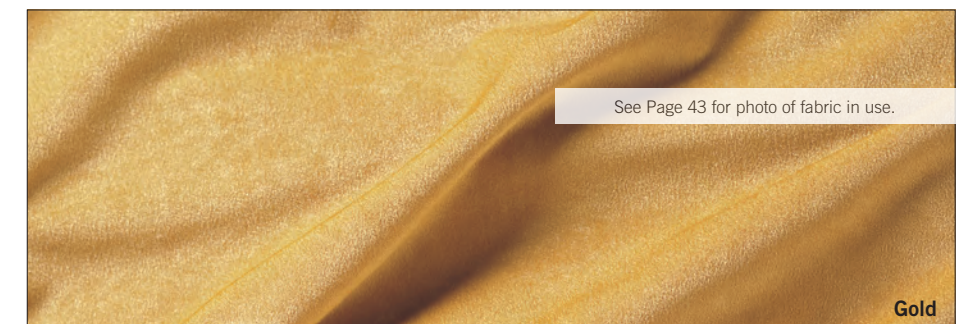

See Page 43 for photo of fabric in use.

Gold



### 10 OZ. POLYVEL

**Inherently Flame Retardant.** This super economical lightweight brushed velour has a smooth finish and vibrant colors.

Roll = Approx. 100-120 yds.

60" IFR	Price Per Yard		
	Cut	Full Roll	500+ Yds*
	8.95	5.95	4.95

#### VOLUME DISCOUNT

\*Must be Purchased in Full Roll/Piece Increments.



Red







Most Popular!

**21 OZ. MARVEL**

**Flame Retardant.** Medium weight. Used in venues ranging from high school and college theaters to Broadway shows and national tours. Black and 25 colors (left). In stock and ready to ship. Custom colors available — 200 yd. min.

Roll = Approx. 80-90 yds.

	Price Per Yard	
	Cut	Full Roll
54" Black	19.50	15.00
54" Colors	21.60	16.60

Most Popular!

**25 OZ. MEMORABLE**

**Flame Retardant.** Heavy weight, opaque with a rich, long nap. Used in grand drapes and valances in major theatrical applications worldwide. Stocked in Black. Rose Brand or custom colors available by special order — 200 yd. min.

Roll = Approx. 65-75 yds.

	Price Per Yard	
	Cut	Full Roll
54" <b>FR</b> Black	21.45	16.50
54" <b>FR</b> Colors	24.20	18.60

**20 OZ. MERLIN**

**Flame Retardant.** Medium weight and still 99% opaque. Premium light absorbing velour for when you really need to create a black hole. 100% cotton. Black in stock.

Roll = Approx. 40 yds.

	Price Per Yard	
	Cut	Full Roll
59" Black	36.25	29.00

**21 OZ. VIRTUE**

**Flame Retardant.** Medium weight. Shorter, denser nap than Marvel. Colors require approximately 3 week lead time and minimum 200 yard order.

Roll = Approx. 70-90 yds.

	Price Per Yard	
	Cut	Full Roll
54" Black	21.30	16.40
54" Colors	N.A.	18.00

**25 OZ. MAJESTIC**

**Flame Retardant.** Heavy weight and opaque with a shorter, denser nap than Memorable. Black in stock. Other colors require approximately 3 week lead time and minimum 200 yard order.

Roll = Approx. 50-60 yds.

	Price Per Yard	
	Cut	Full Roll
54" Black	24.50	18.90
54" Colors	N.A.	19.80

**32 OZ. MAGIC**

**Flame Retardant.** The heaviest weight velour in standard use. Opaque with an extra long nap, Magic affords an ultra-rich look and superior sound dampening. Black in stock. Other colors require approximately 3 week lead time and minimum 200 yard order.

Roll = Approx. 50-60 yds.

	Price Per Yard	
	Cut	Full Roll
54" Black	27.30	21.00
54" Colors	N.A.	23.00

**25 OZ. WIZARD**

**Flame Retardant.** With a fine mercerized yarn at 1,190 pile tufts/inch<sup>2</sup>, Wizard traps light and doesn't let it out. 100% cotton. Opaque. Black in stock.

Roll = Approx. 70-85 yds.

	Price Per Yard	
	Cut	Full Roll
54" Black	37.70	29.00

**16 OZ. PRINCESS**

**Flame Retardant.** 100% cotton. Lightweight and economical, with traditional matte finish. Used in theaters, industrial shows, special events, and stock draperies. In stock and ready to ship in all colors show below. Custom colors available — 200 yd. min.

Roll = Approx. 80-100 yds.

	Price Per Yard	
	Cut	Full Roll
54" <b>FR</b> Black	14.87	11.75
54" <b>FR</b> Colors	15.18	12.00

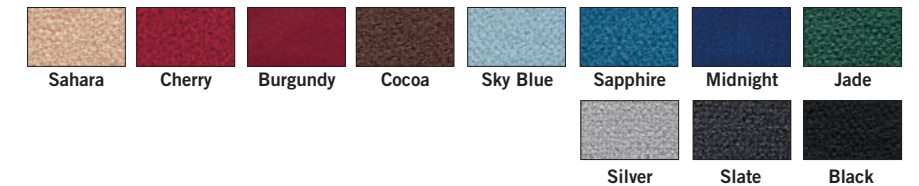
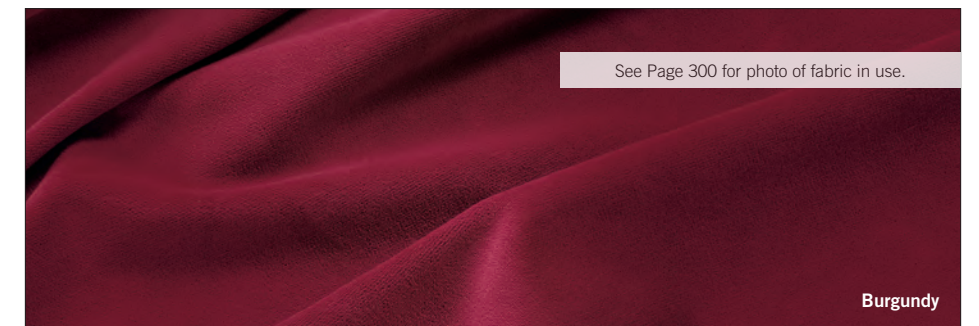

Product: 8 oz. Super Vel; *Cabaret*, Arden Theatre Company; Designer: David P. Gordon; Scene Shop: Arden Theatre Company; Photo: Mark Garvin

- Fabrics
- Black Masking
- Custom Stage Curtains & Backdrops
- Custom Special Event Sewing
- Digital Printing
- LED Star Drops
- Pipe & Base
- Rentals
- Projection Materials
- Flooring
- Curtain Track
- Stage Equipment, FXs & Mirrors
- DMX Winches
- Scenery Props
- Shop & Production Supplies
- Tape
- Film & Video Supplies
- Index





Product: Avora Lining. Photo: Yazmin Gomez

## Lining Fabric

### LINING FABRIC

Rolls of fabric wider than 100" must ship via common carrier.

FABRIC	SPECIFICATIONS					PRICE PER YARD		
	Width	Color	Additional Colors	Properties	Approximate Roll / Piece Size	Cut	Full Roll	500+ Yds
<b>FR RANGER</b>	54"	Black		100% Cotton. Use as lining for velour draperies.	100 yds.	8.25	5.50	
<b>IFR RB CLOTH</b>	72"	Black	See pg. 128	AKA "PD Cloth".	90 yds.	12.75	8.50	7.00
<b>IFR POLY PREMIER</b>	61"	Black	See pg. 127	100% Polyester. Economical and durable liner. Also available in 11 colors.	100 yds.	6.40	4.25	3.75
<b>IFR AVORA™ LINING</b>	56"	Black		Economical synthetic for lining synthetic velour drapes. VISA® Intrinsic IFR polyester.	100 yds.	8.65	5.75	5.25
<b>IFR AVORA™ LINING PLUS</b>	126"	Black		A heavier version of our Avora™ lining with greater opacity and protection of face fabric. VISA® Intrinsic IFR polyester.	110 yds.	10.25	6.25	4.95
<b>IFR BLACKOUT LINING</b>	54"	White/White		70% Polyester/30% Cotton. <i>Also known as 3-Pass Foam.</i> Total light blockage protects from sunlight damage. For use as a lining for window draperies.	60 yds.	10.25	6.25	4.95
	54"	Grey/White			60 yds.	10.40	8.00	
	54"	Black/Grey			60 yds.	10.40	8.00	
	110"	White/White			60 yds.	16.38	12.60	
<b>IFR BLACKOUT SATIN</b>	58"	See Below	See pg. 108	Totally opaque. Medium weight with a soft hand.	50 yds.	13.50	9.00	7.50
<b>IFR POLYANNA</b>	54"	Black White	See pg. 97	An economical artificial silk liner that's also great for dressing event spaces.	60-90 yds.	6.82	5.25	

#### AVORA LINING



Black

#### AVORA LINING PLUS



Black

#### BLACKOUT LINING



White/White



Grey/White

#### BLACKOUT SATIN



Black

#### POLYANNA



Black

#### RANGER

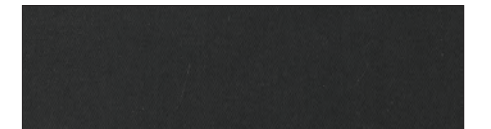

Black

#### RB CLOTH



Black

#### POLY PREMIER



Black

- Fabrics
- Black Masking
- Custom Stage Curtains & Backdrops
- Custom Special Event Sewing
- Digital Printing
- LED Star Drops
- Pipe & Base
- Rentals
- Projection Materials
- Flooring
- Curtain Track
- Stage Equipment, FXs & Mirrors
- DMX Winches
- Scenery Props
- Shop & Production Supplies
- Tape
- Film & Video Supplies
- Index



# Commando Cloth & Duvetyn

## FR BLACK COMMANDO

FABRIC	SPECIFICATIONS				PRICE PER YARD			
	Width	Weight	Color	Properties	Approximate Roll / Piece Size	Cut	Full Roll	500+ Yds*
FR COMMANDO	Most Popular! 54"	16 oz.	Black	Known on the West Coast as Duvetyn. The most widely used back masking fabric in the entertainment industry.	50 or 100 yds.	9.20	5.25	4.95
	60"	16 oz.	Black	5' width saves sewing time and prevents waste on many common sizes of finished backings.	100 yds.	11.20	8.00	6.90
	78"	16 oz.	Black	Extra width allows for fewer seams	100 yds.	19.50	13.00	11.25
FR DOUBLE FACED COMMANDO	118"	16 oz.	Black	Brushed finish on both sides. Extra width allows for 9' seamless panels. Cut yardage may be folded for UPS shipping.	65 yds.	22.50	15.00	13.50
FR LIGHTWEIGHT COMMANDO	54"	12 oz.	Black	Between 8 oz. Duvetyn and 16 oz. Commando Cloth in weight. Ideal for backdrops on a limited budget.	50 or 100 yds.	7.50	5.00	4.25
FR LIGHTWEIGHT COMMANDO	118"	12 oz.	Black	Between 8 oz. Duvetyn and 16 oz. Commando Cloth in weight. Ideal for backdrops on a limited budget.	60 yds.	18.48	14.45	12.75

\*Must be purchased in full roll/piece increments.

## IFR BLACK COMMANDO

FABRIC	SPECIFICATIONS				PRICE PER YARD			
	Width	Weight	Color	Properties	Approximate Roll / Piece Size	Cut	Full Roll	500+ Yds*
IFR COMMANDO	62"	16 oz.	Black	Permanently flame resistant alternative to regular commando. 100% polyester. Not compatible with 118".	50-60 yds.	12.75	8.75	7.60
	118"	16 oz.	Black	Permanently flame resistant alternative to regular commando. 100% polyester. Not compatible with 62".	50-60 yds.	27.50	21.95	17.20

\*Must be purchased in full roll/piece increments.

## FR BLACK DUVETYN

FABRIC	SPECIFICATIONS				PRICE PER YARD			
	Width	Weight	Color	Properties	Approximate Roll / Piece Size	Cut	Full Roll	500+ Yds*
FR DUVETYN	54"	8 oz.	Black	The most economical black masking fabric available. Light-weight 8 oz. cotton with a brushed matte finish. For masking below stages and other areas where there is no light source behind the material.	50 or 100 yds.	6.75	4.50	3.85
	118"	8 oz.	Black	Extra width allows for 9' seamless panels. Cut yardage may be folded for UPS shipping.	65 yds.	13.57	10.60	9.55

\*Must be purchased in full roll/piece increments.

## FR BLACK WOOL SERGE

FABRIC	SPECIFICATIONS				PRICE PER YARD			
	Width	Weight	Color	Properties	Approximate Roll / Piece Size	Cut	Full Roll	500+ Yds*
FR WOOL SERGE	59"	30 oz.	Black	Used widely in Europe for maskings, 59" wide, 30 oz. wool serge has a matte finish with no nap direction.	60 yds.	25.50	20.40	17.50

\*Must be purchased in full roll/piece increments.

## FR COMMANDO COLORS

FABRIC	SPECIFICATIONS				PRICE PER YARD		
	Width	Weight	Color	Properties	Approximate Roll / Piece Size	Cut	Full Roll
FR COMMANDO COLORS	54"	16 oz.	See Chart for Colors	A unique and durable drapery fabric. Opaque, lighter and more economical than velour. Used in theater, industrial shows, social events, and stock draperies.	100 yds.	9.88	7.70
FR DOUBLE FACED COMMANDO COLORS	118"	16 oz.	White	Great when both sides are seen. Highly reflective.	65 yds.	21.76	17.00
FR LIGHTWEIGHT COMMANDO COLORS	118"	12 oz.	See Chart for Colors	Light-weight (12 oz.) 100% cotton Commando Cloth in colors is a versatile and durable drapery fabric, and is lighter and more economical than velour. Used in theatre, industrial shows, special events, and stock draperies.	60 yds.	18.48	14.45

## FR DUVETYN COLORS

FABRIC	SPECIFICATIONS				PRICE PER YARD		
	Width	Weight	Color	Properties	Approximate Roll / Piece Size	Cut	Full Roll
FR DUVETYN COLORS	54"	8 oz.	See Chart for Colors	An economical, lightweight fabric with a brushed matte finish in five colors and black.	100 yds.	7.94	6.20



## LITEOUT™

**Inherently Flame Retardant.** The lightest weight blackout fabric available. Water and tear resistant, LiteOut can be used as a liner or as a stand alone blackout.

Roll = Approx. 54 yds.

\*Must ship on roll.

Width	IFR	Price Per Yard	
		Cut	Full Piece
120"	IFR	35.00	25.00



Black

The lightest weight full blackout fabric available.

## LITEOUT™ B/W

**Inherently Flame Retardant.** Black on one side, plus a highly reflective white side for superior projection results. Significant sound blocking is an added bonus.

Roll = Approx. 54 yds.

\*Must ship on roll.

Width	IFR	Price Per Yard	
		Cut	Full Piece
122"	IFR	39.00	29.00

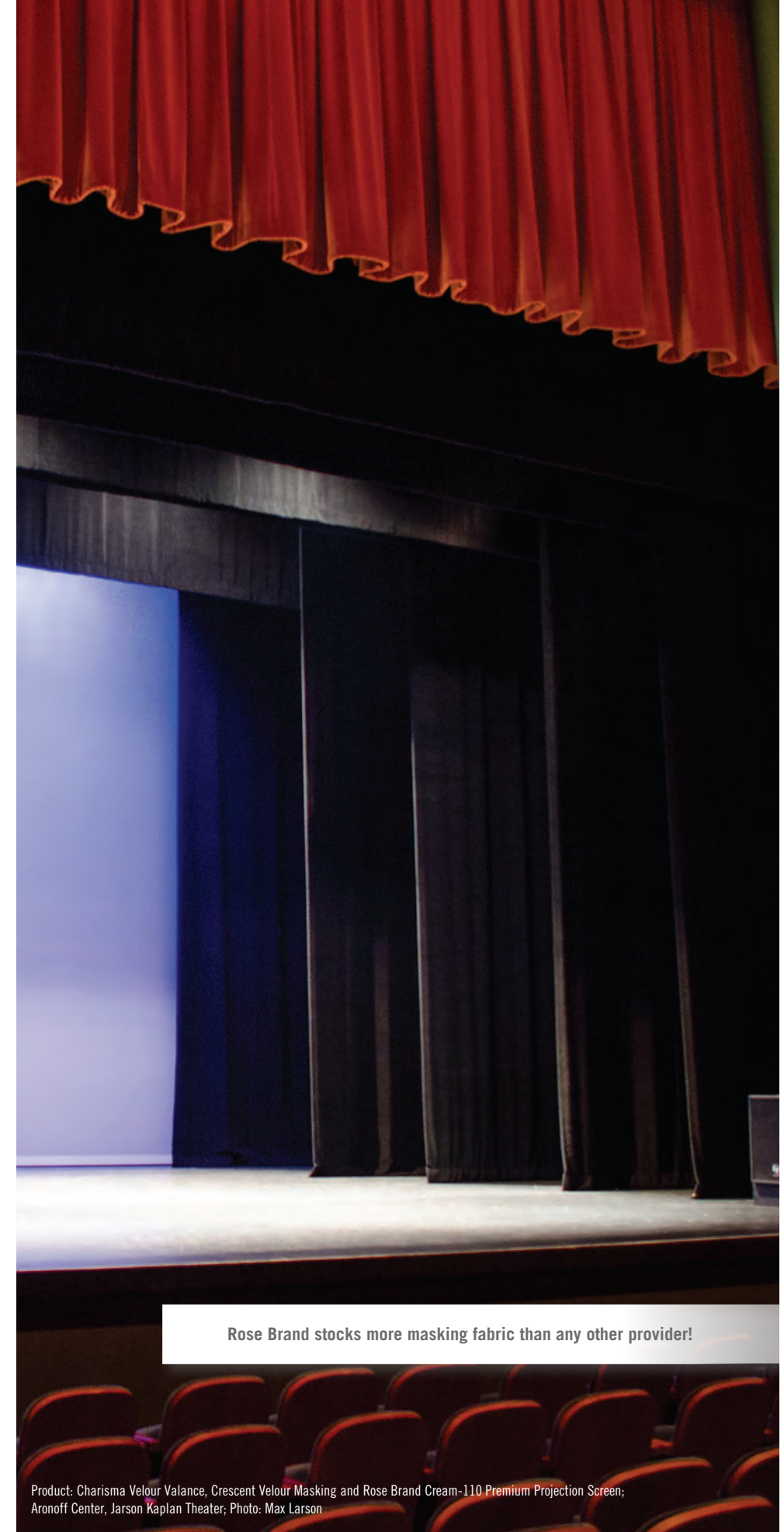

Rose Brand stocks more masking fabric than any other provider!

Product: Charisma Velour Valance, Crescent Velour Masking and Rose Brand Cream-110 Premium Projection Screen, Aronoff Center, Jarson Kaplan Theater; Photo: Max Larson

- Fabrics
- Black Masking
- Custom Stage Curtains & Backdrops
- Custom Special Event Sewing
- Digital Printing
- LED Star Drops
- Pipe & Base
- Rentals
- Projection Materials
- Flooring
- Curtain Track
- Stage Equipment, FXs & Mirrors
- DMX Winches
- Scenery Props
- Shop & Production Supplies
- Tape
- Film & Video Supplies
- Index



# MASKING FABRIC SELECTOR

Masking curtains are an indispensable element of stagecraft. They are almost always black and have the job of blocking and absorbing light and sound and to focus the audience's attention on the featured performance and scenery. In the Theatre masking usually consist of legs, borders, tabs and blackout curtains.

Masking fabrics also have many uses outside of theatre. They are widely used for arena and bowl reduction, defining spaces in large events as well as light management on TV, film sets, to name a few.

This chart will help you narrow down your choice of masking fabrics to suit the requirements of your projects and budgets.

## Blackness

The blacker and more neutral, the better to absorb light. These descriptions are somewhat subjective but can serve to help narrow down your choices.

## Light Block/Opacity

Very few fabrics are a total UV light block, but if they are at least 90% opaque they can be used as functionally opaque in most settings if there are not lights shining directly on the back of the curtains.

## Acoustic Sound Absorption

All of the masking fabrics provide sound dampening while some are better than others. As always with acoustics, the characteristics of the fabric are one of several important factors in the context of any particular venue along with the distance from walls, fullness, lining and other architectural elements.

## Masking Fabrics

### IFR SYNTHETICS

Fabric	Width	Page	Blackness	Light Block/Opacity	Acoustic Sound Absorption	Comments	Price Per Yard		
							Cut	Full Piece	500+
32 OZ. ROYALE	54"	p. 29	Superior	99%	Very Good	Heavy weight deep pile for large scale venues.	N.A.	31.20	
25 OZ. CHARISMA	54"	p. 30	Best IFR Black	90%	Very Good	The most widely used IFR velour for permanent masking.	27.95	21.50	
22 OZ. ENCORE	64"	p. 33	Good	99%	Best	The standard for schools, durable and wrinkle resistant.	22.23	18.50	
20 OZ. CRESCENT	54"	p. 30	Superior	90%	Very Good	Widely used for high end tours and permanent house masking.	22.50	17.30	
23 OZ. ATHENA	60"	p. 37	Superior	95%	Very Good	Good for schools and arena reduction masking.	25.50	17.00	15.00
14 OZ. MAGICIAN	54"	p. 31	Superior	85%	Good	Very black light weight napped velour.	19.75	15.80	
13 OZ. APOLLO	54"	p. 40	Good	85%	Good	Most economical napped IFR velour.	17.95	13.80	
15 OZ ENCORE	62"	p. 33	Good	70%	Very Good	The standard for rental masking, durable and wrinkle resistant.	15.94	12.75	
16 OZ. ATHENA	60"	p. 37	Superior	90%	Very Good	Great for arena reduction masking.	16.50	11.00	9.50
12 OZ. BRAVA	54"	p. 41	Standard	100%	Satisfactory	The most economical IFR light blocking masking.	11.75	9.00	
IFR 16 OZ. COMMANDO	62"	p. 46	Standard	99%	N.A.	The most economical 99% light blocking masking.	12.75	8.75	7.60
ARENA CLOTH	130"	p. 31	Standard	70%	Good	Great Sq Ft coverage/ \$	29.25	19.50	

### FR NATURAL FIBER

Fabric	Width	Page	Blackness	Light Block/Opacity	Acoustic Sound Absorption	Comments	Price Per Yard		
							Cut	Full Piece	500+
25 OZ. WIZARD	54"	p. 42	Best	85%	Good	Super light absorbency.	37.70	29.00	
20 OZ. MERLIN	59"	p. 42	Superior	90%	Good	The blackest, most light absorbing.	36.25	29.00	
32 OZ. MAGIC	54"	p. 42	Superior	99%	Best	Heavy weight deep pile for large venues.	27.30	21.00	
30 OZ. WOOL SERGE	59"	p. 46	Good	99%	Very Good	No nap/pile direction. Most popular in Europe.	25.50	20.40	17.50
25 OZ. MEMORABLE	54"	p. 42	Superior	99%	Best	Most widely used cotton velour for permanent masking.	21.45	16.50	
21 OZ. MARVEL	54"	p. 42	Good	90%	Good	Widely used for show masking.	19.50	15.00	
16 OZ. COMMANDO	54"	p. 46	Standard	99%	N.A.	The most economical masking that is opaque.	9.20	5.25	4.95
12 OZ. LT. WGT. COMMANDO	54"	p. 46	Standard	70%	N.A.	A good buy when opacity isn't necessary.	7.50	5.00	4.25
8 OZ. DUVETYN	54"	p. 46	Standard	50%	N.A.	The most economical masking for covering area, but not blocking light	6.75	4.50	3.85

**ORDER OF LISTING** Inherently Flame Retardant synthetics are listed separately from Flame Retardant natural fiber fabrics, and the fabrics are listed in descending order of price from the most expensive to the least.

**COMMENTS** These brief comments are meant as a starting point in the process of Rose Brand helping you to focus on the best options for your application.

 Fabrics for which we have acoustical test results available online.

- Fabrics
- Black Masking
- Custom Stage Curtains & Backdrops
- Custom Special Event Sewing
- Digital Printing
- LED Star Drops
- Pipe & Base
- Rentals
- Projection Materials
- Flooring
- Curtain Track
- Stage Equipment, FXs & Mirrors
- DMX Winches
- Scenery Props
- Shop & Production Supplies
- Tape
- Film & Video Supplies
- Index





# CUSTOM DYE Quickly And In Small Batches

FABRICS WE CAN

## FR Synthetic Velour

Minimum Order - 200 yds. Lead time - 3 weeks. Lab Dips are available.

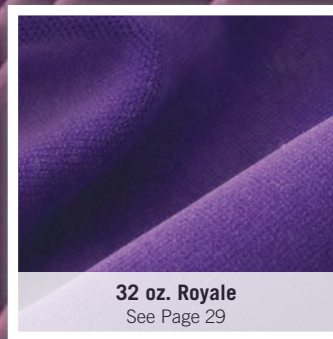

32 oz. Royale  
See Page 29



32 oz. Imperial  
See Page 29



25 oz. Charisma  
See Page 30



25 oz. Prestige  
See Page 30



20 oz. Crescent  
See Page 30



20 oz. Empress  
See Page 34



13 oz. Apollo  
See Page 40

## FR Cotton Velour

Minimum Order - 200 yds. Lead time - 3 weeks. Lab Dips are available.

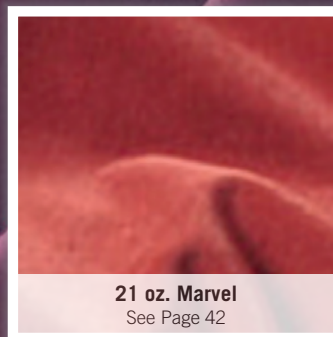

21 oz. Marvel  
See Page 42

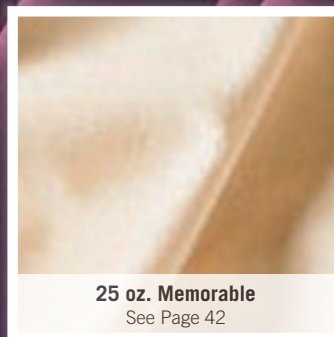

25 oz. Memorable  
See Page 42

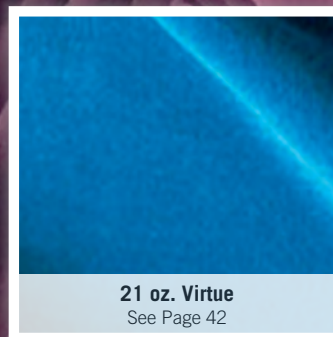

21 oz. Virtue  
See Page 42

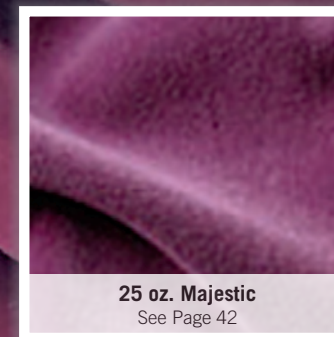

25 oz. Majestic  
See Page 42

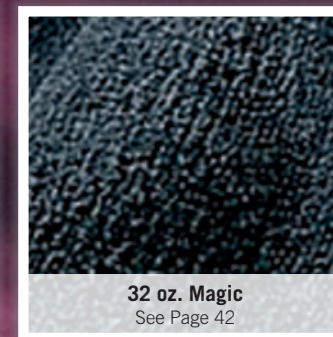

32 oz. Magic  
See Page 42

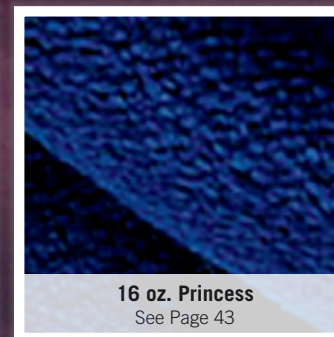

16 oz. Princess  
See Page 43

## FR Scenic Fabrics

Minimum Order - 60 yds. Lab Dips are not available.



Muslin  
See Page 56



Sharktooth Scrim  
See Page 60



Leno Filled Scrim  
See Page 61

We can custom dye many of our fabrics, but here's the list of ones that we can do relatively quickly and in relatively small batches, as indicated here.



- Fabrics
- Black Masking
- Custom Stage Curtains & Backdrops
- Custom Special Event Sewing
- Digital Printing
- LED Star Drops
- Pipe & Base
- Rentals
- Projection Materials
- Flooring
- Curtain Track
- Stage Equipment, FXs & Mirrors
- DMX Winches
- Scenery Props
- Shop & Production Supplies
- Tape
- Film & Video Supplies
- Index



**CANVAS,  
MUSLIN, SCRIM,  
LENO, GAUZE,  
NETTING,  
BOBBINETTE  
AND MORE**



Product: Painted Muslin, Argo Starch; *Beyond the Shore*, Joffrey Ballet, Choreographer: Nick Blanc; Designer: Mark Stanley; Scene Shop: Scenic Art Studios; Photo: Lawrence Gregorek

Our scenic fabrics are the artist's choice for painted backdrops, ground cloths, and scrims. Select the one with the most appropriate width, weight, weave, transparency, and paintability for your use. If you're looking for a sewn fabric for your backdrop, call for a price quote. We have short lead times and reasonable pricing.

**PAINTER'S LINEN**

Scenic and fine artists have used linen for centuries because of its durability and the beautiful way it takes paint.

Roll = Approx. 56 yds.

**MONK'S CLOTH**

100% cotton, 4 x 4 thread basket weave. (Allow 1 week for **FR** treatment.)

Roll = Approx. 50 yds.

	Price Per Yard	
	Cut	Full Roll
120" NFR	45.00	36.00

		Price Per Yard	
		Cut	Full Roll
60"	NFR	10.40	8.00
60"	<b>FR</b>	13.55	11.00



Painter's Linen

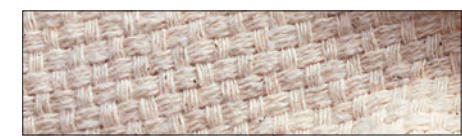

Monk's Cloth

CANVAS						
Rolls of fabric over 100' must ship via common carrier.						
FABRIC	SPECIFICATIONS			PRICE PER YARD		
	Width	Weight	Color	Approximate Roll / Piece Size	Cut	Full Piece
<b>NFR CANVAS</b> 100% Cotton. Durable, tightly woven fabric, also known as duck cloth. Commonly used for ground cloths, murals and decorative floor cloths. Unprimed. Wider pieces can be folded for UPS shipment.	72"	7 oz. (#16)	Natural	125 yds.	5.34	3.80
	128"	10½ oz. (#14)	Natural	55 yds.	20.28	15.60
	72"	12 oz. (#12)	Natural	100 yds.	8.40	6.00
	84"	12 oz. (#12)	Natural	100 yds.	10.22	7.30
	120"	12 oz. (#12)	Natural	50-65 yds.	16.64	12.80
	144"	12 oz. (#12)	Natural	50 yds.	22.83	17.55
<b>FR CANVAS</b>	60"	18 oz. (#10)	Natural	100-130 yds.	10.39	7.70
	68"	7 oz.	Natural	100 yds.	8.10	6.00
	70"	12 oz.	Natural	100-130 yds.	12.21	9.20
	68"	8 oz.	Black	100 yds.	8.36	6.20
<b>FR CANVAS COLORS</b>	68"	15 oz.	Black	100 yds.	14.38	10.65
	108"	6 oz.	White	54 yds.	24.88	19.90
	60"	7 oz.	White, French Pink, Charcoal, Black	100 yds.	7.75	6.20
<b>NFR CANVAS EXTRA-WIDE</b> Highest Quality, Tight Weave	14'5"	9 oz.	Natural	65 yds.	46.20	36.96
	23'7"	9 oz.	Natural	65 yds.	90.98	72.77
	32'9"	9 oz.	Natural	65 yds.	135.08	108.05
<b>FR CANVAS EXTRA-WIDE</b>	14'5"	9 oz.	Natural	65 yds.	68.93	55.13
	23'7"	9 oz.	Natural	65 yds.	128.10	102.48
	32'9"	9 oz.	Natural	65 yds.	176.40	141.12
	14'5"	9 oz.	White	65 yds.	79.43	63.53
	23'7"	9 oz.	White	65 yds.	154.35	123.48
	32'9"	9 oz.	White	65 yds.	214.99	171.99



Natural

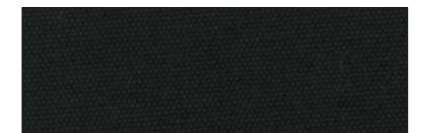

Black



White



French Pink



Charcoal

Product: Muslin; *The Pajama Game*; North Rockland High School; Designer: James Huppert; Photo: James Huppert



- Fabrics
- Black Masking
- Custom Stage Curtains & Backdrops
- Custom Special Event Sewing
- Digital Printing
- LED Star Drops
- Pipe & Base
- Rentals
- Projection Materials
- Flooring
- Curtain Track
- Stage Equipment, FXs & Mirrors
- DMX Winches
- Scenery Props
- Shop & Production Supplies
- Tape
- Film & Video Supplies
- Index



# Muslin

See Pages 53, 56-57, 120, 123, 231, 233, 242 and 320 for photos of fabric in use.



Natural

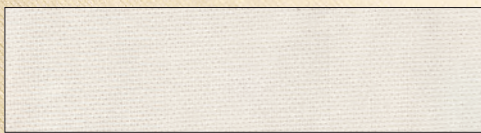

White



Light Grey

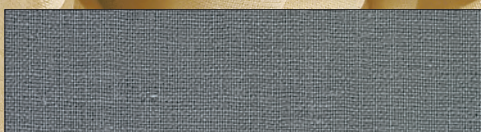

Dark Grey



Light Blue



Dark Blue

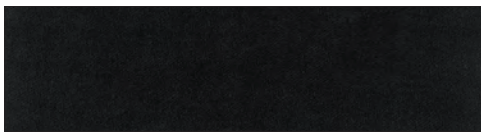

Black

## STANDARD MUSLIN

FABRIC	SPECIFICATIONS			PRICE PER YARD				
	Color	Width	Weight	Approximate Roll / Piece Size in Yards	Cut	Full Piece	300+ Yards*	Rolled or Folded
NFR NATURAL		45"	Light	50	3.59	2.00		Rolled
		44"	Medium	50	4.08	2.50		Rolled
		59"	Heavy	135	5.95	3.95		Rolled
		60"	Medium	135	5.03	3.35	2.95	Rolled
		72"	Heavy	100	6.00	4.00		Folded
		76"	Medium	120	5.12	3.40		Folded
		80"	Heavy	100	6.40	4.25		Both
		84"	Medium	120	5.63	3.75		Folded
		90"	Heavy	100	6.60	4.40		Rolled
		108"	Heavy	135	7.95	5.30	4.65	Folded
		120"	Medium	135	7.58	5.05	4.30	Folded
		120"	Heavy	135	8.25	5.50	4.80	Folded
		126"	Heavy	65	9.38	6.25	4.95	Rolled
		140"	Heavy	100	9.83	6.55	5.90	Folded
FR NATURAL		56"	Heavy	100	6.40	4.25		Rolled
		75"	Medium	100	7.42	4.95		Rolled
		77"	Heavy	100	8.55	5.70		Rolled
		98"	Heavy	100	9.40	6.25		Rolled
		108"	Movie	109	11.65	7.75	6.60	Rolled
		110"	Heavy	100	10.40	6.95	5.50	Rolled
		110"	Medium	100	10.05	6.70		Rolled
		126"	Heavy	65	15.50	10.35	8.20	Rolled

## STANDARD MUSLIN

FABRIC	SPECIFICATIONS				PRICE PER YARD				
	Color	Width	Weight	FR	Approximate Roll / Piece Size in Yards	Cut	Full Piece	300+ Yards*	Rolled or Folded
WHITE		108"	Heavy	FR	109	12.60	8.40	7.30	Rolled
		108"	Movie	FR	109	13.05	9.00	7.70	Rolled
		126"	Heavy	FR	65	16.50	11.00	9.00	Rolled
		108"	Heavy	NFR	109	10.50	7.00		Rolled
LT. GREY		108"	Heavy	FR	109	12.60	8.40		Rolled
		108"	Movie	FR	109	13.05	9.00	7.70	Rolled
		126"	Heavy	FR	65	16.50	11.00	9.00	Rolled
DK. GREY		108"	Heavy	FR	109	12.60	8.40		Rolled
		108"	Movie	FR	109	13.05	9.00	7.70	Rolled
		126"	Heavy	FR	65	16.50	11.00	9.00	Rolled
LT. BLUE		108"	Heavy	FR	109	12.60	8.40		Rolled
		108"	Movie	FR	109	13.05	9.00	7.70	Rolled
DK. BLUE		108"	Heavy	FR	109	12.60	8.40		Rolled
		108"	Movie	FR	109	13.05	9.00	7.70	Rolled
BLACK		108"	Heavy	FR	109	12.60	8.40		Rolled
		108"	Movie	FR	109	13.05	9.00	7.70	Rolled
		126"	Heavy	FR	65	16.50	11.00	9.00	Rolled
		126"	Heavy	NFR	65	18.45	12.30		Rolled

## VOLUME DISCOUNTS FOR MUSLIN YOU USE EVERY DAY



SPECIFICATIONS				PRICE PER YARD				
Width	FR	Weight	Color	Approximate Roll/ Piece Size	Cut	Full Piece	300+ Yards*	Rolled or Folded
60"	NFR	Medium	Natural	135	5.03	3.35	2.95	Rolled
108"	NFR	Heavy	Natural	135	7.95	5.30	4.65	Folded
120"	NFR	Medium	Natural	135	7.58	5.05	4.30	Folded
120"	NFR	Heavy	Natural	135	8.25	5.50	4.80	Folded
140"	NFR	Heavy	Natural	100	9.83	6.55	5.90	Folded
110"	FR	Heavy	Natural	100	10.40	6.95	5.50	Rolled
108"	FR	Heavy	White	109	12.60	8.40	7.30	Rolled
126"	FR	Heavy	White	65	16.50	11.00	9.00	Rolled

\*Must be Purchased in Full Roll/Piece Increments.

## DID YOU KNOW?

### Muslin

Muslin is used virtually everywhere in entertainment production – by costumers, scene painters, in set construction, for cycloramas and bounces and even as projection screens. To accommodate this wide variety of applications, it is available in many different weights, widths, colors.

Flame Retardant (FR) or Non Flame Retardant (NFR) - Many scenic painters prefer to use natural color NFR muslin for **painted backdrops** and then apply a topical FR treatment (see p. 332 for a list of suitable Flame Retardants) after the fabric has been painted. This is because FR muslin which has been treated by the mill with a durable flame retardant chemical may react with wet paint, causing a bloom of white residue to appear on top of the paint finish. Regardless of which material you specify, it is crucial to comply with local regulations and to insure a safe venue.

Choosing the proper weight and width of the muslin you need is determined by the project. Select the most cost-effective and efficient size to place seams where they will be least visible on your project. Medium and heavy weight materials have similar properties but vary in hand and strength.

For **cycloramas, bounces, and projection screens** Bleached White or Light Grey FR muslin is the typical choice of most professionals.

**Seamless translucent backdrops** are determined by the size needed and the painter's preference for FR or NFR goods. Tight Weave muslin offers advantages over standard muslin when some areas of the translucent design need to be painted opaque. The closer thread construction makes it easier to fill and properly opaque without overly saturating the fabric with a heavy stiff layer of paint.

Inherently Flame Retardant (IFR) muslin is available and is a great choice for installations that want to insure proper fire retardance without the effort of periodic retreatment, such as cyc and screens in permanent venues. However, the synthetic yarns in IFR muslin are NOT suitable for painting.

### Buy Muslin by the Full Piece and Save!

All roll and bale sizes are approximate and based on availability. We can only offer full piece pricing for piece sizes we have in stock at the time of your order. If you need to know the exact yardage on available full pieces, let us know.

**Cut pieces are rolled or folded. If this is critical, please let us know.**

### Weights

There are 4 common weights of muslin:

- **Lightweight** – used by costumers for a lining fabric or patterning.
- **Medium Weight** – used for hard-covered flats or small drops.
- **Heavy Weight** – used for soft-covered flats and large drops.
- **Movie Weight** – Movie Muslin's weight and construction makes it ideal for light diffusion.

**MUSLIN  
IN STOCK  
AND  
READY TO SHIP**

- Fabrics
- Black Masking
- Custom Stage Curtains & Backdrops
- Custom Special Event Sewing
- Digital Printing
- LED Star Drops
- Pipe & Base
- Rentals
- Projection Materials
- Flooring
- Curtain Track
- Stage Equipment, FXs & Mirrors
- DMX Winches
- Scenery Props
- Shop & Production Supplies
- Tape
- Film & Video Supplies
- Index



# Muslin



Natural



White

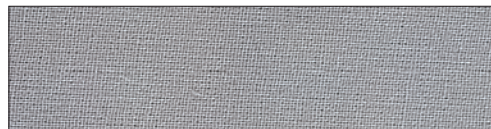

Light Grey

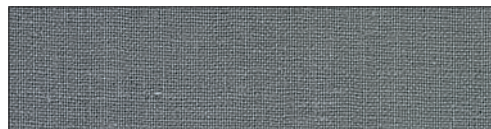

Dark Grey



Light Blue

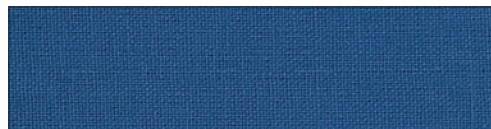

Dark Blue



Black



### CUSTOM DYED EXTRA-WIDE MUSLIN

We can match a color swatch or Pantone® number in most widths of our **FR** Extra-Wide Muslin. Minimum = Approx. 30 yds.

Allow 3 weeks lead time.

## EXTRA WIDE MUSLIN

Heavy Weight, Approximate Piece Size 65 yds, Comes Folded

### Extra Wide NFR Muslin - Natural

NFR muslin in natural is the standard in theatre production for painted backdrops, skies, painted cycloramas and translucencies. Whether seamed or seamless widths, NFR Muslin should be sized to properly prepare the surface for paint. After painting, treat with the appropriate flame retardant solution to insure adequate protection and to meet local fire regulations.

### Extra Wide FR Muslin

Pre-treated with fire retardants to meet local fire regulations, FR Muslin is great for bounces, cycs, and projection surfaces. When painting on FR muslin, avoid over saturating the fabric with paint or water to minimize the migration of FR salts to the surface of the paint.

FABRIC	SPECIFICATIONS	PRICE PER YARD	
Color	Width	Cut	Full Piece
NFR NATURAL	12'	16.50	11.00
	14' 5"	22.10	17.00
	16' 5"	26.00	20.00
	17'	28.60	22.00
	20' 4"	39.00	30.00
	21'	42.90	33.00
	26' 8"	93.60	72.00
	32' 9"	104.00	80.00
FR NATURAL	12'	150.00	115.00
	12'	24.70	19.00
	14' 5"	36.40	28.00
	16' 5"	40.30	31.00
	17'	44.20	34.00
	20' 4"	75.40	58.00
	21'	83.20	64.00
	26' 8"	119.60	92.00
FR WHITE	32' 9"	145.60	112.00
	39'	205.40	158.00
	12'	27.30	21.00
	14' 5"	39.00	30.00
	16' 5"	48.10	37.00
	17'	52.00	40.00
	20' 4"	83.20	64.00
	21'	91.00	70.00
FR LT. BLUE & LT. GREY	26' 8"	135.20	104.00
	32' 9"	182.00	140.00
	39'	241.80	186.00
	12'	29.90	23.00
	14' 5"	63.70	49.00
	16' 5"	74.10	57.00
	17'	78.00	60.00
	21'	117.00	90.00
FR BLACK	26' 8"	156.00	120.00
	32' 9"	221.00	170.00
	39'	286.00	220.00
IFR WHITE TREVIRA	12'	29.90	23.00
	14' 5"	49.40	38.00
	21'	109.20	84.00
IFR WHITE TREVIRA	13' 9"	45.00	36.00
	17'	52.00	40.00
	20' 4"	83.20	64.00
IFR WHITE TREVIRA	32' 9"	195.00	150.00

Product: Extra Wide Canvas; Boston Ballet's Sleeping Beauty; Designer: David Walker; Scene Shop: Mystic Scenic Studios; Photo: Mark Marengi

# Muslin

## EXTRA WIDE TIGHT WEAVE MUSLIN

Heavy Weight, Approximate Piece Size 65 yds, Comes Folded

Extra Wide Tight Weave Muslin is superior for painting translucent drops when some areas need to be painted opaque. The closer thread construction makes it easier to fill and properly opaque without overly saturating the fabric with a heavy stiff layer of paint. Makes excellent seamless projection screens as large as 40' x 180' for either front or rear projection. Note that the Tight Weave has slightly lower transmission than our Standard extra wide muslin when used as an RP surface.

FABRIC	SPECIFICATIONS	PRICE PER YARD	
Color	Width	Cut	Full Piece
NFR NATURAL	26' 10"	80.60	62.00
	33' 6"	89.70	69.00
	39' 8"	126.10	97.00
FR NATURAL	26' 10"	105.30	81.00
	33' 6"	119.60	92.00
	39' 8"	176.80	136.00
FR WHITE	26' 10"	123.50	95.00
	33' 6"	143.00	110.00
	39' 8"	218.40	168.00
FR LT. GREY	26' 10"	145.60	112.00
	33' 6"	161.20	124.00
	39' 8"	239.20	184.00

### **NEW** 33' 6" IFR MUSLIN FOR CYCS AND SCREENS

A new 100% PET construction makes this extra wide muslin inherently fire retardant – perfect for cycloramas, projection surfaces and anywhere a permanent FR treatment is needed. Not suitable for scenic paint treatments. Care must be taken in handling and storage to avoid hard creases and wrinkles.

FABRIC	SPECIFICATIONS	PRICE PER YARD	
Color	Width	Cut	Full Piece
IFR BLACK	33' 6"	230.00	172.50
IFR GREY	33' 6"	230.00	172.50
IFR WHITE	33' 6"	189.00	141.00

- Fabrics
- Black Masking
- Custom Stage Curtains & Backdrops
- Custom Special Event Sewing
- Digital Printing
- LED Star Drops
- Pipe & Base
- Rentals
- Projection Materials
- Flooring
- Curtain Track
- Stage Equipment, FXs & Mirrors
- DMX Winches
- Scenery Props
- Shop & Production Supplies
- Tape
- Film & Video Supplies
- Index



## Full Size Netting Comparison

This chart is designed to make it easier for you to select the net or gauze best suited to your project. Each image is shown at actual size to help compare the weave styles and opening size of the various materials. For more information about each type of net, refer to their product page.

All Samples Scale 1:1

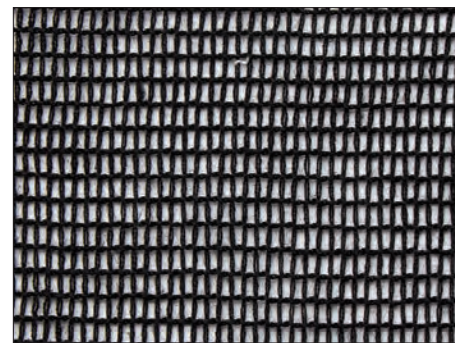

SHARKSTOOTH SCRIM PAGE 60

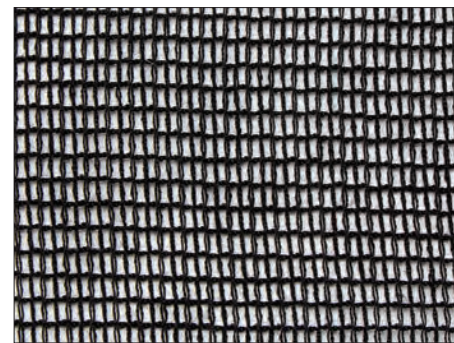

6 POINT/3 THREAD SCRIM PAGE 61

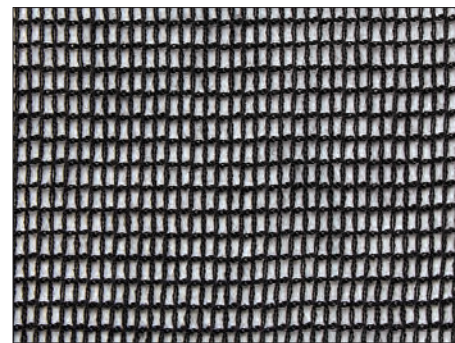

TREVIRA® CS SCRIM PAGE 61

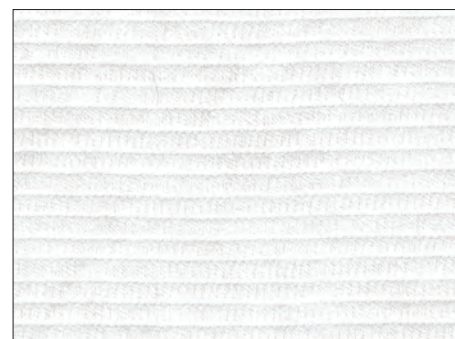

LENO FILLED SCRIM PAGE 61



PAINTER'S SCRIM PAGE 61

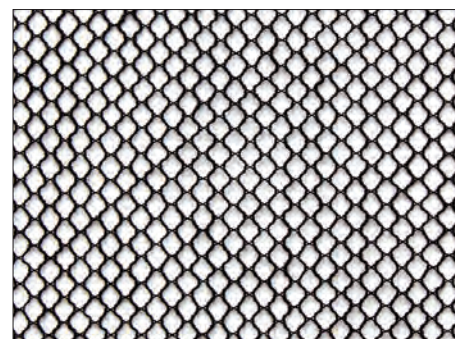

BOBBINETTE WEAVE A PAGE 62

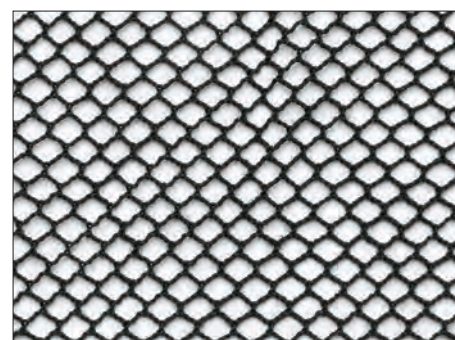

BOBBINETTE WEAVE B PAGE 62



THEATRICAL GAUZE PAGE 66



SINGLE CINETENET PAGE 347



DOUBLE CINETENET PAGE 347

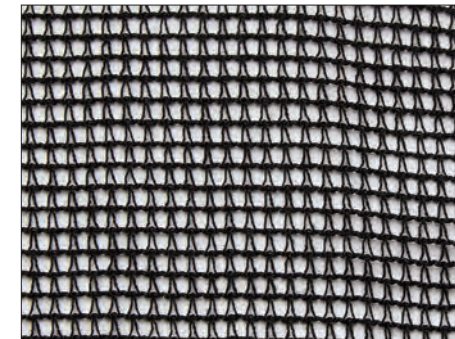

TRANSNET PAGE 62



SQUARE GAUZE PAGE 64

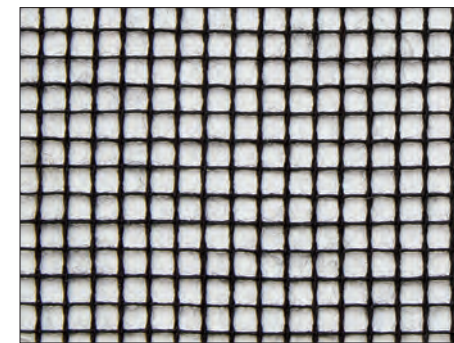

XNET PAGE 65

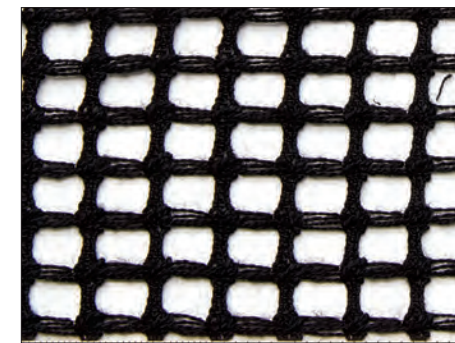

TIGER GAUZE PAGE 63

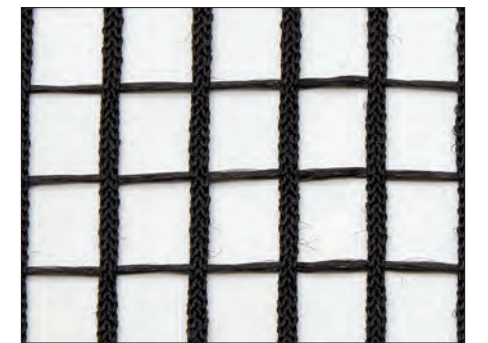

KENNY NET PAGE 63

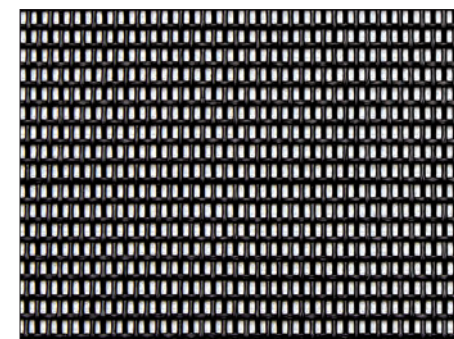

TEXTILENE® PAGE 64

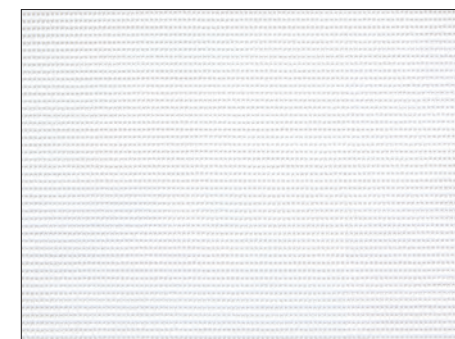

MESH 30 PAGE 76



MESH 70 PAGE 76



BLOWTHROUGH PAGE 78



1 X 1 SCENERY NETTING PAGE 64



13'3" SCENERY NET PAGE 64





Product: Painter's Scrim; *Oklahoma!*, Civic Center Music Hall; Producer: Lyric Theatre, Oklahoma City; Director: Nick Demos; Designer: Michael Schweikardt; Lighting Designer: Helena Kukka; Scene Shop and Construction: Virginia Scenic; Photo: Michael Schweikardt

All Samples Scale 1:1

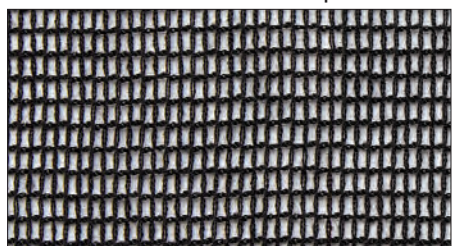

Black



White

### TREVIRA® CS SCRIM

**Inherently Flame Retardant.** 8 point, 2 thread construction. The resin coating provides a more uniform and stable finish than previously possible with synthetic scrim, while not affecting its Inherent Flame Retardancy.

Full Piece = Approx. 55-66 yds.

		Price Per Yard	
		Cut	Full Piece
White	35'	IFR 132.50	106.00
Black	35'	IFR 145.00	116.00

### 6 POINT / 3 THREAD SCRIM

Flame Retardant. 100% Cotton. The traditional 3 thread construction has long been the standard for major European opera and theatre. 6 point/3 thread construction provides durability and a more substantial surface for paint and light without sacrificing smooth bleed-through.

Full Piece = Approx. 60 yds.

		Price Per Yard	
		Cut	Full Piece
White	35'	FR 120.00	96.00
Black	35'	FR 130.00	104.00
Lt. Grey	35'	FR 130.00	104.00



White



Black



Light Grey

### PAINTER'S LENO

Non Flame Retardant. 100% Cotton. Identical to regular Leno, Painter's Leno is not bleached, dyed or flame treated, and its textured surface takes paint beautifully.

Full Piece = Approx. 40 or 54 yds.

		Price Per Yard	
		Cut	Full Piece
Natural	29'	NFR 140.40	112.30



Natural

### LENO FILLED SCRIM

**Flame Retardant.** 100% Cotton. Used for bounce drops and cycloramas, Leno's weave is like that of Sharktooth Scrim, but with the openings filled in. The resulting textured surface diffuses and softens reflective light, making it a favorite of the lighting designers.

Full Piece = Approx. 40-50 yds.

		Price Per Yard	
		Cut	Full Piece
White	19'	FR 137.50	100.00
	29'	FR 170.00	136.00
	38'6"	FR 192.50	154.00
Lt. Blue	19'	FR 156.00	124.80
	29'	FR 197.60	158.10
Lt. Grey	19'	FR 147.50	118.00
	29'	FR 185.00	148.00
	38'6"	FR 195.00	156.00



White



Light Blue



Light Grey

### PAINTER'S SCRIM

Non Flame Retardant. 100% Cotton. Identical to Sharktooth Scrim, Painter's Scrim is not bleached, dyed or Flame Retardant, making it a favorite of scenic artists.

Full Piece = Approx. 60 yds.

		Price Per Yard	
		Cut	Full Piece
Natural	36'	NFR 70.00	56.00
	39'	NFR 80.00	64.00

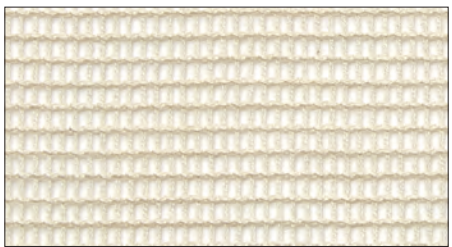

Natural

## DID YOU KNOW?

### Sharktooth Scrim

Sharktooth Scrim is an open weave net, meaning there is more open space than actual fabric. The opening of our standard 2-thread construction weave is 1/8" by 1/16". Sharktooth Scrim is primarily used to achieve the "bleed through" effect i.e., magically revealing items upstage of the scrim. When lit properly, Sharktooth Scrim can appear either opaque or transparent. These effects are then used to perform conceals and reveals. Sharktooth Scrim can also be used to create the illusion of distance.

Leno, or leno-filled scrim, can be described as "Sharktooth Scrim with the holes filled in." Leno has a lovely soft, textured surface that reflects light beautifully, making it ideal for a cyclorama or a bounce drop. Leno-filled scrim is also ideal for projecting abstract shapes and patterns, due to its highly reflective surface. The texture, however, will mitigate high resolutions, so leno is not the best surface for video projection.

Use these fabrics with our Stretcher Frame System on Page 248.

Great solution for "Hourglassing" and Puckering.

All Samples Scale 1:1

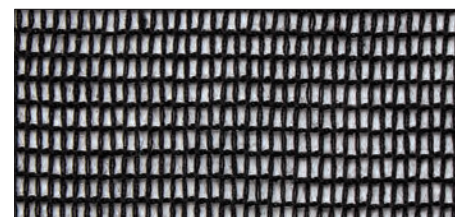

Black

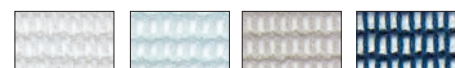

White



Light Blue



Light Grey



Dark Blue

Buy or Rent

### SHARKSTOOTH SCRIM

**Flame Retardant.** 100% Cotton. 8 point, 2 thread construction. Weave opening is 1/8" x 1/16", used for the "bleed-through" effect. Can be painted, sewn into a finished drop, or attached to a frame or scenery. The "tooth" of scrim will normally be vertical, but the scrim will be as effective if the tooth is horizontal. This may allow a more efficient use of the width of the scrim. See Pages 60, 133 and 164 for photos of fabric in use.

		Price Per Yard		Price Per Yard			
		Cut	Full Piece	Cut	Full Piece		
Black	10'9"	FR 55.00	44.00	White	10'9"	FR 50.00	40.00
	15'6"	FR 60.00	48.00		15'6"	FR 55.00	44.00
	19'6"	FR 75.00	60.00		19'6"	FR 70.00	56.00
	25'	FR 93.75	75.00		25'	FR 86.25	69.00
	31'	FR 102.50	82.00		31'	FR 96.25	77.00
Lt. Grey	35'	FR 127.50	102.00	35'	FR 103.75	83.00	
	39'	FR 138.75	111.00	39'	FR 130.00	104.00	
	31'	FR 122.50	98.00	Lt. Blue	15'6"	FR 70.00	56.00
	Dk. Blue	31'	FR 122.50		98.00	19'6"	FR 82.50
			31'		FR 125.00	100.00	
				35'	FR 142.50	114.00	



## Bobbinette

All Samples Scale 1:1

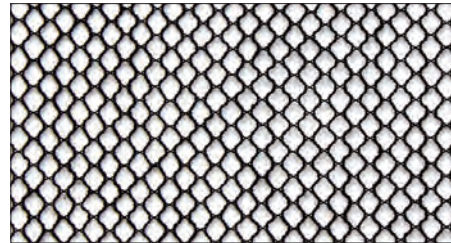

Black



White

### BOBBINETTE - WEAVE A

**Flame Retardant.** 100% Cotton. Bobbinettes have a more open weave than Sharkstooth Scrim or Square Gauze. Often used in combination with Sharkstooth Scrim or in front of rear projection screens to reduce glare and increase contrast. Various weaves give designers a range of light transmission values to create depth and to give a soft, hazy look to images.

Full Piece = Approx. 50-55 yds.

		Price Per Yard		
			Cut	Full Piece
White	10'	FR	38.17	29.35
Black	10'	FR	42.17	32.45
White	30'	FR	105.51	81.15
Black	30'	FR	111.18	86.50



Black



White

### BOBBINETTE - WEAVE B

**Flame Retardant.** 100% Cotton. Bobbinettes have a more open weave than Sharkstooth Scrim or Square Gauze. Often used in combination with Sharkstooth Scrim or in front of rear projection screens to reduce glare and increase contrast. Various weaves give designers a range of light transmission values to create depth and to give a soft, hazy look to images.

Full Piece = Approx. 22-30 yds.

		Price Per Yard		
			Cut	Full Piece
White	31'	FR	112.48	86.50
Black	31'	FR	120.54	92.70
White	39'4"	FR	125.58	96.50
Black	39'4"	FR	136.50	105.00



Black



White

### TRANSNET

**Flame Retardant.** 100% Cotton. A unique new weave design provides a level of light transmission nearly as high as Bobbinette without the instability and extreme "hourglassing" of the hexagonal Bobbinette weave. A great alternative for a seamless full stage netting, especially in touring situations where stretcher frames cannot be used to hold out the sides of the drop. See Page 72-73 for fabric in use.

Full Piece = Approx. 60 yds.

		Price Per Yard		
			Cut	Full Piece
White	39'	FR	162.50	130.00
Black	39'	FR	170.00	140.00

Use these bobbinette fabrics with our Stretcher Frame System on Page 248.

Great solution for "Hourglassing" and Puckering.

## Netting & Gauze

All Samples Scale 1:1

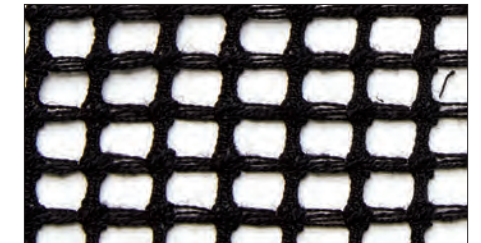

Black



White

### TIGER GAUZE

**Flame Retardant.** 100% Cotton. Heavy duty 1/4" square netting has more body than other scenery netting and creates subtle lighting. Ideal for Precision Cut projects adding a sense of depth similar to bobbinette while remaining virtually transparent.

Full Piece = Approx. 60 yds.

		Price Per Yard		
			Cut	Full Piece
White	32'	FR	132.50	101.90
Black	32'	FR	137.91	106.10

Working hand in hand with Boston based **Mystic Scenic Studios**, Rose Brand's Project Management Team provided Precision Cutting Technology to produce the intricate lacy quality of this drop designed by **Benjamin Phillips** for **Boston Ballet**. Using our **22 oz Encore™ Velour** as the base fabric, the precise cuts were etched throughout the fabric leaving a clean fray-free edge. Mystic Scenic Studio's team of scenic artists stabilized the open areas of the precision cut Encore Velour by gluing it down on our **Tiger Gauze** netting.



Close-up view of photo above.

### KENNY NET

**Flame Retardant.** Waterproof, highly stable netting with 1/2" grid. Ideal for outdoor or indoor use. Ask us about adding clip-on LEDs to produce an amazing see-through Animation Curtain or Star Drop.

Full Roll = 56 yds.

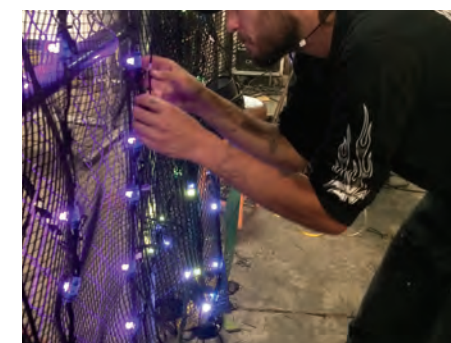

		Price Per Yard		
			Cut	Full Piece
13'5"	FR		111.50	90.00



Black

[Blog](#) Creating a Custom LED Drop Using Kenny Net and LED Pixels - <http://bit.ly/KennyNetBlog>

All Rose Brand Flame Resistant Fabrics Pass NFPA 701 testing. See [RoseBrand.com](http://RoseBrand.com) for additional FR standards and registration numbers.



## Netting & Gauze

All Samples Scale 1:1

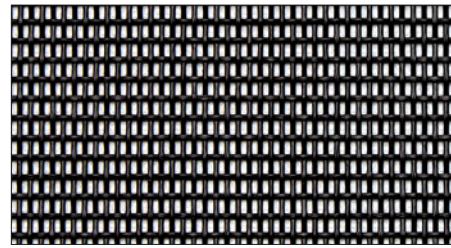

Black



White

Silver

### TEXTILENE®

**Inherently Flame Retardant/Non Flame Retardant.** PVC Coated Polyester. Sturdy weatherproof mesh used for covering outdoor concert scaffolding and speaker towers, and for backdrops with lighting and laser projection. Low acoustic absorption. Textilene's open mesh decreases wind resistance at outdoor venues. Available in 6 additional colors (54" only), see page 130.

Roll = Approx. 60 yds.

			Price Per Yard	
			Cut	Full Piece
White	54"	NFR	13.42	8.95
Black	54"	NFR	13.42	8.95
White	98"	IFR	24.00	16.00
Black	98"	IFR	24.00	16.00
Silver	98"	IFR	24.00	16.00



Black



White

### 1 x 1 SCENERY NETTING

**Inherently Flame Retardant.** 100% Polyester. 1" square netting for stabilizing the open areas of cut drops and foliage drops.

Full Piece = 24 yds.

			Price Per Yard	
			Cut	Full Piece
White	32'	IFR	81.00	54.00
Black	32'	IFR	81.00	54.00



Black



White

### 13'3" SCENERY NETTING

**Inherently Flame Retardant.** 100% Trevira. Synthetic fiber provides durability for indoor/outdoor use. Opening: 3/8" x 1/2"

Roll = Approx. 40-55 yds.

			Price Per Yard	
			Cut	Full Piece
White	13'3"	IFR	32.66	24.20
Black	13'3"	IFR	32.66	24.20

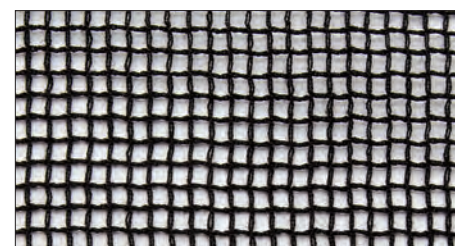

Black



White

### SQUARE GAUZE

**Flame Retardant.** 100% Cotton. Often used to soften images or create a heightened sense of depth on stage. Can be used in combination with Sharkstooth Scrim or Bobbinette without creating the moiré effect that results when identical open-weave fabrics are doubled up. Also useful to mask ceilings below sprinklers where unrestricted water flow is a critical factor.

Full Piece = Approx. 60 yds.

			Price Per Yard	
			Cut	Full Piece
White	35'	FR	125.74	96.70
Black	35'	FR	131.15	100.90

## Netting & Gauze

All Samples Scale 1:1

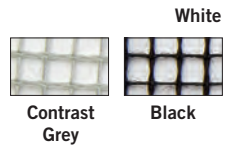
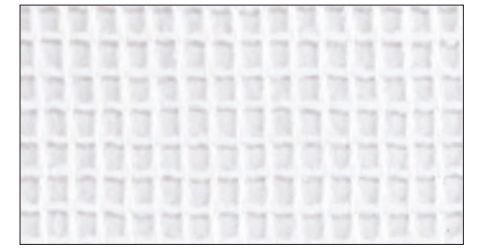

Contrast Grey

White

Black

### XNET

**Inherently Flame Retardant.** This sturdy and stable 1/8" square poly netting is color fast and UV resistant making it great for lighting effects indoors or out. Also an internationally accepted standard for trade show booth ceilings.

Roll Size = Approx. 66 yds.

			Price Per Yard	
			Cut	Full Piece
White	16'5"	IFR	32.50	26.00
Black	16'5"	IFR	38.75	31.00
Grey	16'5"	IFR	38.75	31.00

### SPEAKER CLOTH

**Flame Retardant.** 100% Cotton. Combining a brushed surface for masking with good acoustical qualities at a wide width. Fabric shipped half folded and rolled on a core.

Roll = Approx. 55 yds.

			Price Per Yard	
			Cut	Full Piece
Black	102"	FR	10.13	7.50

Also see **Sonic Stretch** acoustical fabric on page 75.



Black



Product: Scrim; American Ballet Theatre; Scene Shop: Michael Hagen Inc.; Choreographer: Alexei Ratmansky; Scenery and Costume Design: Richard Hudson; Dancers: American Ballet Theatre; Photo: Gene Schiavone



## Netting & Gauze

All Samples Scale 1:1



Natural



White

### COTTON SCRIM

**Flame Retardant/Non Flame Retardant.** 100% Cotton. Ultra-fine gauze that drapes beautifully. Used in special events and interior decorating as well as in theatres for quick and economical swags and billows that are light as a feather.

Roll = Approx. 100 yds.

		Price Per Yard		
		Cut	Full Piece	
Natural	55"	NFR	3.24	1.75
Natural	54"	FR	6.46	4.15
White	55"	NFR	3.24	1.75
White	54"	FR	6.46	4.15



Natural



Black

White

### FINE GAUZE

100% Cotton. Fine Gauze is a lightweight cotton available in wide, seamless widths with a beautiful, consistent and stable weave.

Full Piece = Approx. 65-72 yds.

		Price Per Yard		
		Cut	Full Piece	
Natural	9'9"	NFR	9.75	6.50
Natural	9'9"	FR	12.75	8.50
White	9'9"	FR	16.50	11.00
Black	9'9"	FR	17.25	11.50
Natural	19'6"	NFR	26.25	21.00
Natural	19'6"	FR	44.00	36.00
White	19'6"	FR	56.00	40.00
Black	19'6"	FR	62.40	48.00
Natural	32'9"	NFR	78.00	60.00



Natural



Off-White

### THEATRICAL GAUZE

**Flame Retardant/Non Flame Retardant.** 100% Linen. Theatrical Gauze is a durable but light gauze with a rustic texture that, when properly lit, allows a bleed-through effect similar to that of Sharktooth Scrim.

Roll = Approx. 55 yds.

		Price Per Yard		
		Cut	Full Piece	
Natural	72"	NFR	18.75	12.50
Off-White	72"	NFR	20.62	13.75
Natural	66/67"	FR	21.00	14.00
Off-White	66/67"	FR	22.25	15.00

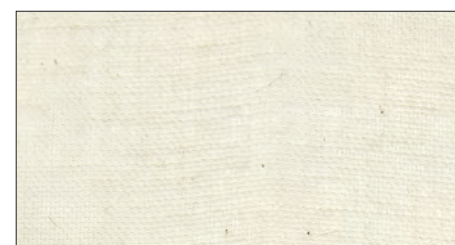

Natural

### CHINCHA

**Can be made Flame Retardant.** 100% Cotton. Tighter weave than cheesecloth. (Allow 1 week for FR treatment. Full roll minimum.)

Full Piece = 100 yds.

		Price Per Roll	
Natural	38"	NFR	165.00

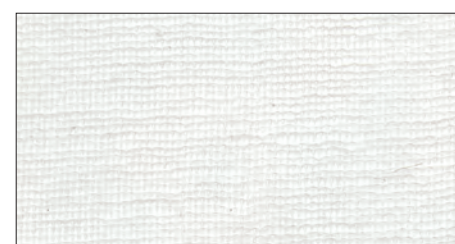

White

### CHEESECLOTH

100% Cotton. Medium grade construction.

70 yd. Box Only.

		Price Per Box	
White	36"	NFR	132.50

## Burlap & Textured

All Samples Scale 1:1

### 7 1/2 OZ. BURLAP

**Can be made Flame Retardant.** Looser weaves. (\$4.50 per yard additional for FR. Allow 2 weeks. 50 yard minimum.)

Full Piece = Approx. 130-150 yds.

		Price Per Yard		
		Cut	Full Piece	
Natural	48"	NFR	3.41	2.20
Natural	72"	NFR	4.34	2.80



Natural

### 10 OZ. BURLAP

**Can be made Flame Retardant.** Dense texture, fine weave. (\$4.50 per yard additional for FR. Allow 2 weeks. 50 yard minimum.)

Full Piece = Approx. 130-150 yds.

		Price Per Yard		
		Cut	Full Piece	
Natural	48"	NFR	3.96	2.55
Natural	72"	NFR	5.08	3.50



Natural

### EXTRA-WIDE BURLAP

100% Jute. Great natural surface for textured treatments at wide widths.

Full Roll = Approx. 55 yds.

		Price Per Yard		
		Cut	Full Piece	
Natural	17'	NFR	46.80	36.00
Natural	17'	FR	62.40	48.00



Natural

### JUTE GAUZE

**Can be made Flame Retardant.** Looser weaves. (\$4.50 per yard additional for FR. Allow 2 weeks.) (50 yard minimum.)

Full Piece = Approx. 130-150 yds.

		Price Per Yard		
		Cut	Full Piece	
Natural	40"	NFR	3.20	1.90

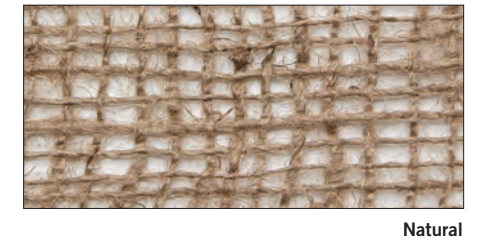

Natural

### 10 OZ. BURLAP COLORS

**Can be made Flame Retardant.** Tight weave burlap. Available in 16 additional colors. See page 122. (Allow 1 week for FR treatment, 50 yard minimum.)

Full Piece = Approx. 50 yds.

		Price Per Yard		
		Cut	Full Piece	
Light Natural	59"	NFR	11.25	7.50
Light Natural	59"	FR	17.25	11.50
Jute Natural	59"	NFR	11.25	7.50
Jute Natural	59"	FR	17.25	11.50



Light Natural



Jute Natural

### EROSION CLOTH

**Can be made Flame Retardant.** Open weave. Used for texture. (\$4.50 per yard additional for FR. Allow 2 weeks. (50 yard minimum.)

Full Piece = Approx. 50 yds.

		Price Per Yard		
		Cut	Full Piece	
Natural	48"	NFR	3.63	2.20



Natural



**KAOS**

**Flame Retardant.** This handmade material features a textured, random, and chaotic quality. Available in fine, medium, heavy, or open thread. Kaos is and can be used in a multitude of ways including set designs, trade shows, special events, interior design, projection, and costumes. Grey Kaos is great for lighting and projection effects. **\*Must ship on a roll. Scale: 2" = 1'.**

Kaos, Fine		Price Per Yard	
Full Piece = Approx. 55 yds.		Cut	Full Piece
Black	118" <b>FR</b>	75.00	63.00
Natural	118" <b>FR</b>	75.00	63.00

Kaos, Medium		Price Per Yard	
Full Piece = Approx. 27 yds.		Cut	Full Piece
Black	118" <b>FR</b>	85.00	71.40
Natural	118" <b>FR</b>	85.00	71.40

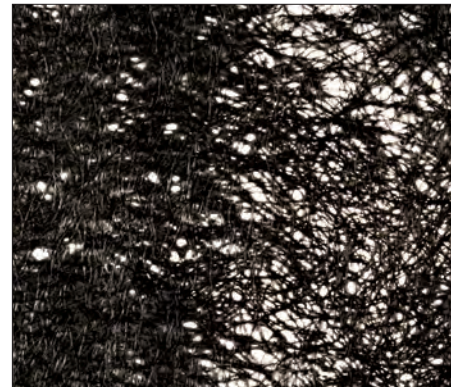

Fine Black

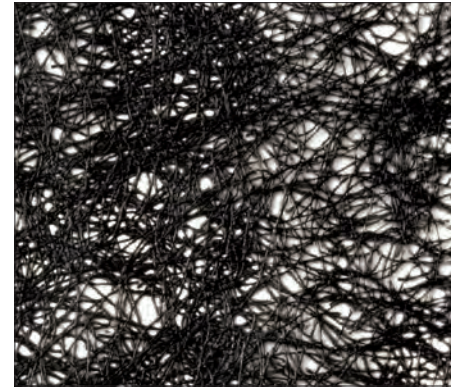

Medium Black

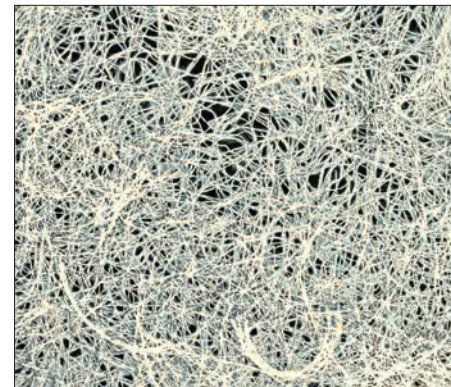

Fine Natural

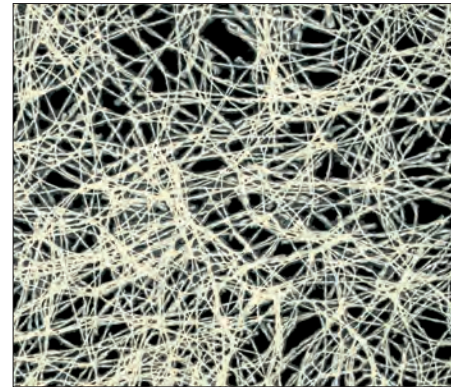

Medium Natural



Kaos, Heavy		Price Per Yard	
Full Piece = Approx. 22 yds.		Cut	Full Piece
Black	118" <b>FR</b>	81.00	68.25
Natural	118" <b>FR</b>	81.00	68.25
Grey	118" <b>FR</b>	81.00	68.25

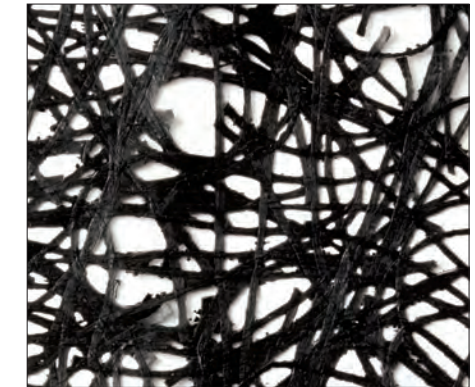

Heavy Black

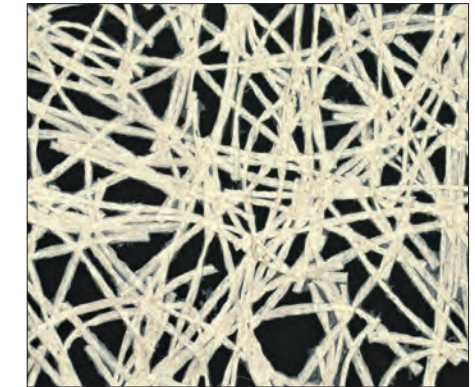

Heavy Natural



Heavy Grey

Kaos, Open		Price Per Yard	
Full Piece = Approx. 27 yds.		Cut	Full Piece
Black	118" <b>FR</b>	81.00	68.25
Natural	118" <b>FR</b>	81.00	68.25
Grey	118" <b>FR</b>	81.00	68.25

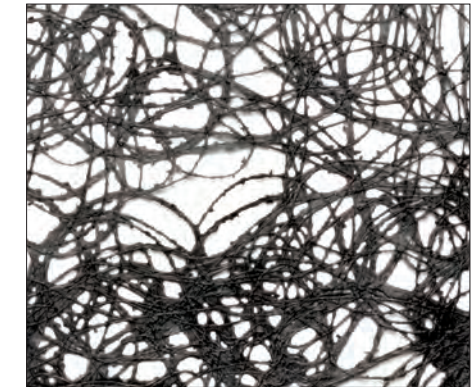

Open Black

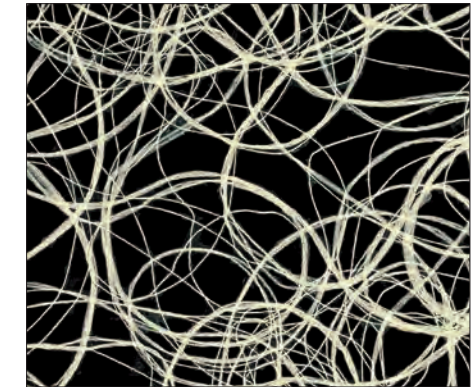

Open Natural

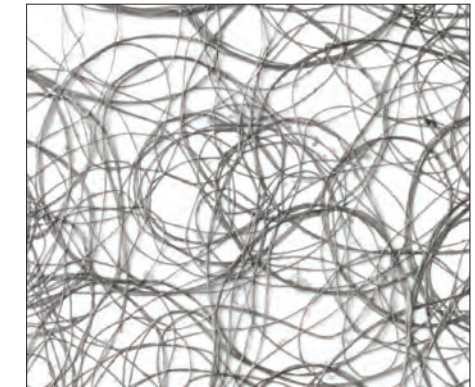

Open Grey

Products: Kaos, Custom Sewing: Heather Henson's Crane, On Earth, In Sky, National Tour, IBEX Puppetry, Scenic Designers: Christopher & Justin Swader, Lighting Designer: Zach Blane, Projection Designer: Katherine Freer, Costume Designer: Donna Zakowska, Sound Designer: Emma Wilk, Scenic Art: Cobalt Studios, Platform: Mind the Gp, Inc., Photo: Justin Swader

- Fabrics
- Black Masking
- Custom Stage Curtains & Backdrops
- Custom Special Event Sewing
- Digital Printing
- LED Star Drops
- Pipe & Base
- Rentals
- Projection Materials
- Flooring
- Curtain Track
- Stage Equipment, FXs & Mirrors
- DMX Winches
- Scenery Props
- Shop & Production Supplies
- Tape
- Film & Video Supplies
- Index



## Barrier & Climbing Nets

Now Available

Netting in a wide range of sizes, styles, color and construction. Useful for safety applications like railings and barriers as well as for scenic elements like nautical rigging, webs, and walls. These nets can be purchased in virtually any size, in an array of colors. Call for pricing.



Natural



### 3 STRAND KNOTTED POLYESTER ROPE NET

A strong polyester construction that won't stretch or degrade like a traditional nautical hemp. Solution dyed tan to mimic sailing nets, these nets are perfect alternatives for scenic use and where live climbing may be required.

Other colors and sizes available. Call for information.

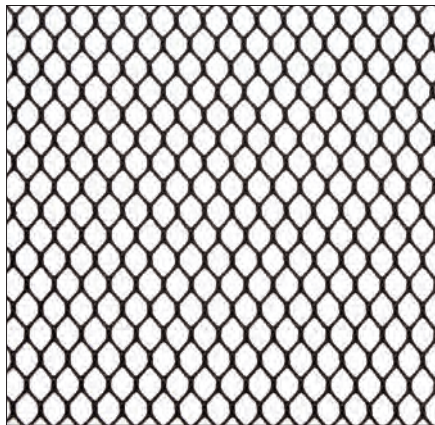

Black



### FR BARRIER NETTING

**Flame Retardant.** Lightweight and abrasion resistant. A versatile  $\frac{3}{8}$ " in mesh that can be used for a variety of purposes. Available in white, black, grey and natural. Call for pricing.



White



### $\frac{3}{4}$ " KNOTLESS NETTING

A strong, traditional square net but made using a knotless, continuous polypropylene filament construction. Available in 1" Black, or  $\frac{3}{4}$ " White. Call for pricing.

Fabrics
Black Masking
Custom Stage Curtains & Backdrops
Custom Special Event Sewing
Digital Printing
LED Star Drops
Pipe & Base
Rentals
Projection Materials
Flooring
Curtain Track
Stage Equipment, FXs & Mirrors
DMX Winches
Scenery Props
Shop & Production Supplies
Tape
Film & Video Supplies
Index





Product: Mesh 70; Black Transnet; Production Design: Jeremy Roth; Scenic Artwork: Valerie Light; Scenic Painting: Cobalt Studios; Scenic Fabrication: Proof Productions; Photos: Jeremy Roth

# 3-Layer Projection Screen Visual Effect

Production Designer, Jeremy Roth, turned to Rose Brand to develop and execute his unique 3-layered projection surface. A cut, tensioned aperture of Mesh 70, backed by a layer of Transnet followed with a second layer of Mesh 70 create the

ideal translucent “sandwich” for lighting and projection effects. Each scrim layer was painted and toned by Cobalt Studios, and the complex touring frame system was built by Proof Productions.



Products used  
Mesh 70 and  
Black Transnet



- Fabrics
- Black Masking
- Custom Stage Curtains & Backdrops
- Custom Special Event Sewing
- Digital Printing
- LED Star Drops
- Pipe & Base
- Rentals
- Projection Materials
- Flooring
- Curtain Track
- Stage Equipment, FXs & Mirrors
- DMX Winches
- Scenery Props
- Shop & Production Supplies
- Tape
- Film & Video Supplies
- Index



## Stretch Fabrics

**ROSE BRAND**  
IS THE LEADING  
**SUPPLIER OF**  
**FLAME RETARDANT**  
STRETCH FABRIC

Product: Tendo Splats. Location: Private residence, Bal Harbour FL. Designer: Swag Decor

Stretch fabrics are used in a broad array of applications such as 3-D structures, projection, acoustics, decoration, and more. We can help you choose the stretch fabric with the properties that best suit your application in terms of stretchability, sound & light transparency, flame retardancy, washability, and color.



### MACRONET™

**Inherently Flame Retardant.** Macronet™ is an ingenious stretch mesh fabric that can be stretched from 17' up to 23'! It's strong and durable construction is well suited for use in tension structures, ceilings and walls. The open weave is great for projection or as an acoustically translucent surface as well. Takes light and images beautifully. For proper sizing, estimate a stretch of 20-35% depending on tension. For example, to cover a 16' wide frame, use Macronet™ that is approximately 12'-10" wide (+25% stretch => 16').

Roll = Approx. 50 yds.

	Price Per Yard	
	Cut	Full Roll
16'4" <b>IFR</b> White	62.00	49.00
16'4" <b>IFR</b> Grey & Black	68.00	54.00



White



Black Grey

### BOOST

Great Stretch in Both Directions

**Inherently Flame Retardant.** Heavy Weight. A breakthrough fabric with the most 4-way stretch possible in an **IFR** fabric. Versatile and sturdy, and an excellent projection surface, Boost is the choice fabric for all stretch applications.

Roll = Approx. 100-107 yds.

	Price Per Yard		
	Cut	Full Roll	500+ Yds*
122" <b>IFR</b>	26.60	19.00	16.50

#### VOLUME DISCOUNT

\*Must be Purchased in Full Roll/Piece Increments.

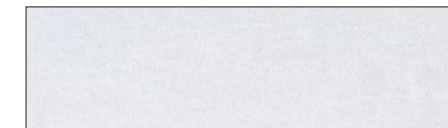

White



Black Red Grey

### NFR SPANDEX

Non Flame Retardant. When your application does not require flame retardant fabric, traditional NFR Spandex has the most stretch you can get.

Roll = Approx. 65-75 yds.

	Price Per Yard	
	Cut	Full Roll
120" NFR	20.82	16.30

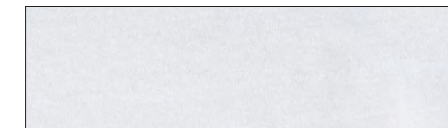

White



Black

### POLY STRETCH

**Flame Retardant.** This 4-way stretch fabric is excellent for projection surfaces. Black, White and Silver. Please use 61" and 120" fabric separately.

Roll of 61" = Approx. 100 yds.

Roll of 120" = Approx. 100 yds.

	Price Per Yard	
	Cut	Full Roll
61" <b>FR</b>	12.00	8.05
120" <b>FR</b> White Only	30.75	20.50



Silver



Black White

### BOOST™

The New IFR Tension Fabric

### TENDO

More Stretch across the 122" width and more stability down the length

**Inherently Flame Retardant.** Medium weight. A rainbow of color is available in our Trevira® CS **IFR** stretch fabric. Great for projection effects and light diffusion. Exclusively at Rose Brand.

Roll = Approx. 100 yds.

	Price Per Yard		
	Cut	Full Roll	500+ Yds*
122" <b>IFR</b> White	32.50	23.00	19.50
122" <b>IFR</b> Colors	35.00	25.00	

#### VOLUME DISCOUNT

\*Must be Purchased in Full Roll/Piece Increments.



White Beige Yellow Tangerine



Pink Red Fuchsia Purple



Sapphire Cobalt Lime Kelly



Grey Black

### SPARKLE & CRACKLE TENDO

**Inherently Flame Retardant.** The most reliable stretch fabric in the industry is now available with glittering highlights without losing any flame retardancy or stretch.

Roll = Approx. 100 yds.

	Price Per Yard	
	Cut	Full Roll
60" <b>IFR</b> Sparkle Tendo	24.60	18.90
60" <b>IFR</b> Crackle Tendo	23.40	18.00

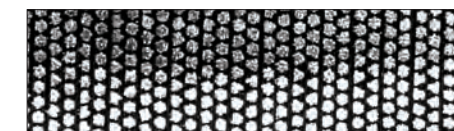

SPARKLE TENDO Silver/Black

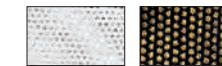

Silver/White Gold/Black



CRACKLE TENDO Silver/Black

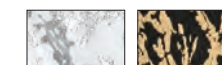

Silver/White Gold/Black

## Stretch Fabrics

### EXTENDA

More stretch down the length and more stability across the 122" width

**Inherently Flame Retardant.** Heavy Weight. An economical and popular choice for lighting effects and diffusion with excellent memory.

Roll = Approx. 70-80 yds.

	Price Per Yard	
	Cut	Full Roll
122" <b>IFR</b>	22.50	18.00

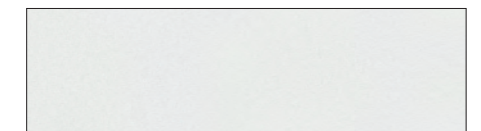

White

### TULLE TEX

**Inherently Flame Retardant.** Trevira CS® 2-way stretch lightweight sheer that provides wide width, transparency and the ability to be stretched to give a smooth, solid surface. White, Black, Silver.

Roll = Approx. 55-75 yds.

	Price Per Yard	
	Cut	Full Roll
13'1" <b>IFR</b>	33.00	22.00

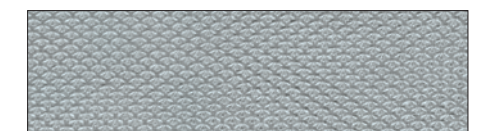

Silver



White

### SONIC STRETCH

**Flame Retardant.** An acoustically transparent soft knit speaker grille fabric that can stretch taut on a frame or be draped. Sonic stretch appears solid and is great for dye sublimation printing. Black & White.

Roll = Approx. 60 yds.

	Price Per Yard	
	Cut	Full Roll
64" <b>FR</b>	18.05	13.00



White



Black



# Specialty Fabrics

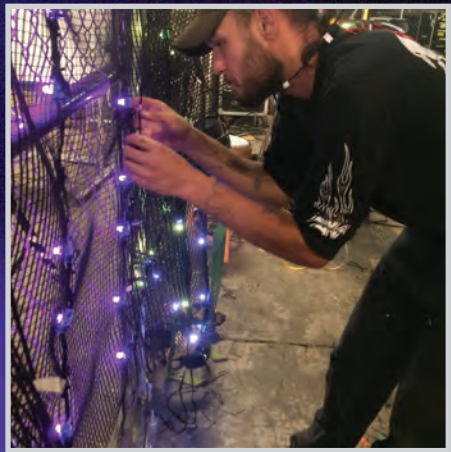

Strong Enough to Hold  
1,850 LED Pixels

Product: Kenny Net; Wilco – Star Wars Tour; Kings Theatre – Brooklyn, NY; Designer: Jeremy Roth – Stageworks; Scene Shop: Stageworks; Photos: Andrew Scott Blackstein/Jeremy Roth

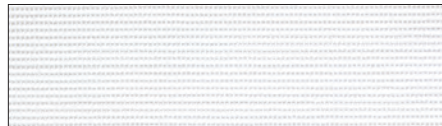

White

## MESH 30

**Inherently Flame Retardant.** Mesh 30 is an IFR, wide width, open weave PVC coated fabric suitable for long-term exterior use. Its fine mesh, basket weave construction allows 30% air-flow through the fabric. Mesh 30 can be printed on or painted and works well as a front projection surface or perforated screen for outdoor use. See fabric in use Page 72-73.

Roll = Approx. 54 yds.

	Price Per Yard	
	Cut	Full Roll
126" <b>IFR</b>	45.00	29.75
16'4" <b>IFR</b>	65.75	43.75



White

## MESH 70

**Inherently Flame Retardant.** Mesh 70 is an IFR, wide width, open weave PVC coated fabric suitable for long-term exterior use. The large mesh, scrim-like construction allows 70% air-flow through the fabric for optimal acoustic transparency and minimal billowing. Mesh 70 can be printed on or painted and works well as a front projection surface.

Roll = Approx. 54 yds.

	Price Per Yard	
	Cut	Full Roll
126" <b>IFR</b>	24.75	16.75
16'4" <b>IFR</b>	36.25	24.75



White

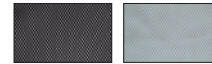

Black

Grey

## MACRONET™

**Inherently Flame Retardant.** Macronet™ is an ingenious stretch mesh fabric that can be stretched from 17" up to 23"! It's strong and durable construction is well suited for use in tension structures, ceilings and walls. The open weave is great for projection or as an acoustically translucent surface as well. Takes light and images beautifully. For proper sizing, estimate a stretch of 20-35% depending on tension. For example, to cover a 16' wide frame, use Macronet™ that is approximately 12'-10" wide (+25% stretch => 16').

Roll = Approx. 50 yds.

	Price Per Yard	
	Cut	Full Roll
16'4" <b>IFR</b> White	62.00	49.00
16'4" <b>IFR</b> Black & Grey	68.00	54.00



Black

## KENNY NET

**Flame Retardant.** Waterproof, highly stable netting with 1/2" grid. Ideal for outdoor or indoor use. Ask us about adding clip-on LEDs to produce an amazing see-through Animation Curtain or Star Drop.

Full Roll = 109 yds.

	Price Per Yard	
	Cut	Full Piece
14' <b>FR</b>	111.50	90.00

**Blog** Creating a Custom LED Drop Using Kenny Net and LED Pixels



Silver



White

Black

## TEXTILENE®

**Inherently Flame Retardant** PVC Coated Polyester. Sturdy weatherproof mesh for covering speaker towers and backdrops with lighting and laser projection. Low acoustic absorption. The 36% open mesh (54") and 28% open (98") decreases wind resistance. 54" NFR colors on page 130.

Roll = Approx. 50-60 yds.

	Price Per Yard	
	Cut	Full Piece
98" <b>IFR</b> Black, White, Silver	24.00	16.00

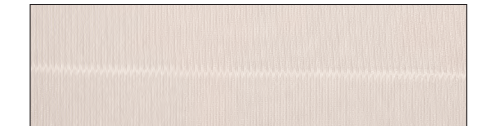

Light Grey

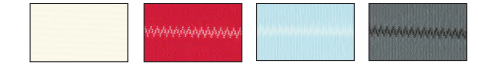

White

Red

Blue

Dark Grey

Black

## MELT OUT

**Inherently Flame Retardant.** New more economical overhead trade show ceiling fabric for stretched ceilings over exhibitions, trade show booths, and museum displays. Melt Out diffuses light beautifully and in the event of a fire, meltable seams every 12" along the length of the fabric open allowing smoke to escape and water from sprinklers to come through.

Roll = Approx. 50 yds.

	Price Per Yard		
	Cut	Full Roll	500+Yds*
96" <b>IFR</b> White	32.10	26.75	21.00
96" <b>IFR</b> Black/Colors	34.80	29.00	22.85

### VOLUME DISCOUNT

\*Must be Purchased in Full Roll/Piece Increments.

- Fabrics
- Black Masking
- Custom Stage Curtains & Backdrops
- Custom Special Event Sewing
- Digital Printing
- LED Star Drops
- Pipe & Base
- Rentals
- Projection Materials
- Flooring
- Curtain Track
- Stage Equipment, FXs & Mirrors
- DMX Winches
- Scenery Props
- Shop & Production Supplies
- Tape
- Film & Video Supplies
- Index





Products: SoftScreen, HD Grey 225 Projection Screen; *The Webby Awards 2017, Cipriani Wall Street*, Designer: David Korins; Scene Shop: Rory Mulholland Scenery; Photo: David Korins Design

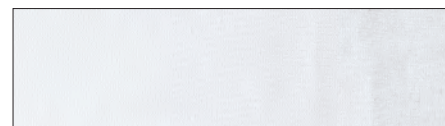

White



Contrast Grey Black

**CELTIC CLOTH**

Most Durable. Great for touring.

**Inherently Flame Retardant.** Medium weight knit with a very soft hand. Wrinkle resistant with a slight stretch that makes a great screen surface when tensioned. Great as a lightweight yet robust touring screen.

Roll = Approx. 95 yds.

	Price Per Yard		
	Cut	Full Roll	500+ Yds*
122" IFR	17.70	9.00	7.85

**VOLUME DISCOUNT**

\*Must be Purchased in Full Roll/Piece Increments.

Roll = Approx. 60 yds.

	Price Per Yard		
	Cut	Full Roll	
13'4" IFR White Only	27.30	21.00	
16'0" IFR White Only	33.80	26.00	

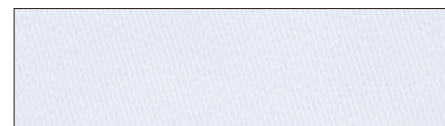

White

**HEAVYWEIGHT CELTIC CLOTH**

Most Durable. Great for touring.

**Inherently Flame Retardant.** A heavy weight version of the popular Celtic Cloth. Additional body and strength make a more robust screen or tension surface with less hot-spotting.

Roll = Approx. 50 yds.

	Price Per Yard	
	Cut	Full Roll
126" IFR	14.30	11.00

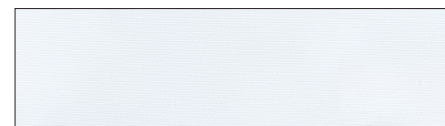

White

**AGLO™**

Best Definition.

**Inherently Flame Retardant.** 16 feet wide, this is the widest rear projection fabric available. This Heavyweight woven polyester fabric is a great light diffuser when backlit and works well as a front or rear projection screen. Aglo is often used for creating large scale lighting effects and its stability makes it ideal for roll drop projection screens. See Page 304 for photo of fabric in use.

Roll = Approx. 55 yds.

\*Must ship on roll.

	Price Per Yard	
	Cut	Full Roll
122" IFR	39.95	29.00
16'4" IFR	56.70	42.00



White

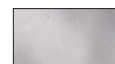

Contrast Grey

**SOFTSCREEN**

Great HD viewing quality. No moiré effect.

**Inherently Flame Retardant.** Excellent for front projection and good for rear projection with minimal hot-spotting. Very soft and wrinkle resistant, SoftScreen is great for touring and events. It deploys smoothly right out of the bag with just enough stretch to create a nice tight surface. See pages 78-79 for photo of fabric in use.

Roll = Approx. 90-100 yds.

	Price Per Yard	
	Cut	Full Roll
122" IFR	33.80	26.00

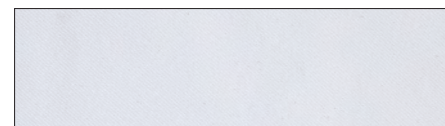

White



Contrast Grey

**HALO**

**Inherently Flame Retardant.** Halo Triple White is a lush, bright white twill with a gorgeous drapable hand. The smooth tight weave makes for an ideal rear projection fabric that won't hot spot or sparkle and can be folded for transport without fear of hard creases. Halo Contrast Grey provides richer colors, deep blacks and high contrast images. Roll = Approx. 50 yds.

	Price Per Yard	
	Cut	Full Roll
118" IFR	18.50	14.50

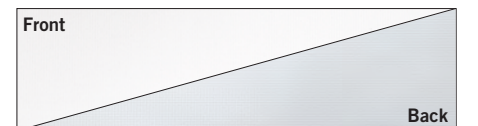

**WHITEOUT** NEW

**Inherently Flame Retardant** Wide-width. The tight weave on this bright white fabric makes an ideal seamless projection surface. The backside has a soft vinyl coating to create a total light block as well as provide a water resistant barrier.

Roll = Approx. 55 yds.

	Price Per Yard	
	Cut	Full Roll
16' 4" IFR	50.75	45.75



- Fabrics
- Black Masking
- Custom Stage Curtains & Backdrops
- Custom Special Event Sewing
- Digital Printing
- LED Star Drops
- Pipe & Base
- Rentals
- Projection Materials
- Flooring
- Curtain Track
- Stage Equipment, FXs & Mirrors
- DMX Winches
- Scenery Props
- Shop & Production Supplies
- Tape
- Film & Video Supplies
- Index





Product: Textilene; Phish, Magna Ball; Photo: Moment Factory

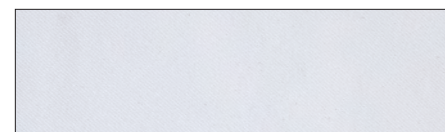

White

**WHITE BLACKOUT SATEEN**

**Inherently Flame Retardant.** White Blackout Sateen is a soft, pliable IFR woven that provides a near complete light block - perfect as a fabric projection screen. White on both sides, the front face of White Blackout Sateen offers a gentle satin surface for the brightest imaging while the rear face is a matte finish to minimize glare - you choose which face is best suited to your project.

Roll = Approx. 50 yds.

	Price Per Yard	
	Cut	Full Roll
118" IFR	18.20	13.00

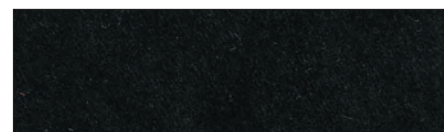

Black

**LITEOUT™**

**Inherently Flame Retardant.** The lightest weight blackout fabric available. Water and tear resistant, LiteOut can be used as a liner or as a stand alone blackout.

Roll = Approx. 54 yds. \*Must ship on roll.

	Price Per Yard	
	Cut	Full Piece
120" IFR	35.00	25.00



**LITEOUT™ B/W**

**Inherently Flame Retardant.** Black on one side, plus a highly reflective white side for superior projection results. Significant sound blocking is an added bonus.

Roll = Approx. 54 yds. \*Must ship on roll.

	Price Per Yard	
	Cut	Full Piece
122" IFR	39.00	29.00



Black

**FR BLACK CORDURA**

**Flame Retardant.** This versatile 100% nylon utility fabric is super strong, durable, water repellent, and quick drying, with excellent resistance to fading, abrasion, puncture, tear, scuffs, rot, and mildew. Heavy duty 1000 Denier Black Cordura will make strong, long-lasting products even tougher. Reverse side is grey.

Roll = Approx. 50 yds.

	Price Per Yard	
	Cut	Full Roll
60" FR	24.00	18.00



White

**SPINNAKER**

**Use in high traffic spaces or when you expect rough handling**

**Flame Retardant.** A wide width White FR Rip Stop nylon, ideal for diffusion or projection. Works well indoors or outdoors.

Roll = Approx. 55 yds.

	Price Per Yard	
	Cut	Full Roll
122" FR	17.50	14.00
164" FR	27.50	22.00



White

**BLACK/WHITE SAIL CLOTH**

**Flame Retardant.** This 100% nylon, opaque fabric has ideal masking properties. It has both a white and a black side, each with a subtle grid pattern. For both outdoor and indoor use. Water repellent.

Roll = Approx. 100 yds.

	Price Per Yard	
	Cut	Full Roll
60" FR	11.85	9.85



White

**BLOW THROUGH™**

**Best for temporary outdoor installations.**

**Inherently Flame Retardant.** Great for lighting effects and projection, this soft, extra wide white fabric has wind perforations for temporary outdoor uses. Ships via Common Carrier.

Roll = Approx. 100 yds.

	Price Per Yard	
	Cut	Full Roll
15" IFR	26.60	19.00

- Fabrics
- Black Masking
- Custom Stage Curtains & Backdrops
- Custom Special Event Sewing
- Digital Printing
- LED Star Drops
- Pipe & Base
- Rentals
- Projection Materials
- Flooring
- Curtain Track
- Stage Equipment, FXs & Mirrors
- DMX Winches
- Scenery Props
- Shop & Production Supplies
- Tape
- Film & Video Supplies
- Index



# Event & Display Fabrics



Product: Gliss Velvet, Voile; The Breakers, Palm Beach FL; Designer: Design Studio at the Breakers & Tommy Murphy, Swag Decor; Event: Engage!16, Wedding Summit

You'll find limitless applications for event & display fabrics, which span the full spectrum of width, weight, finish, color, and texture. Create billows, swags, ribbons, bunting, and chupahs. Or use these fabrics for pipe & drape, projection surfaces, table linens, skirting, overlays, and runners. And if your event requires "acres" of fabric, select from our lower priced and wide width selections that are easy on the budget and easy to install.

# Sheer

## Buy or Rent

### VOILE

**Inherently Flame Retardant.** Our lightweight, semi-transparent Voile is excellent for indoor and outdoor draping of tents and events. 200% - 300% fullness is recommended for draping. Wide width comes half-folded and rolled for shipping.

118" Roll = Approx. 100-200 yds.  
13'9" Roll = Approx. 65 yds.

		Price Per Yard		
		Cut	Full Roll	500+ Yds*
118" IFR	White	5.95	3.95	2.95
118" IFR	Oyster	5.95	3.95	2.95
118" IFR	Colors	6.25	4.15	3.50

### VOLUME DISCOUNT

\*Must be Purchased in Full Roll/Piece Increments.

	Price Per Yard	
	Cut	Full Roll
13'9" IFR White	35.00	28.00
16'5" IFR White <b>New Width</b>	36.00	32.40

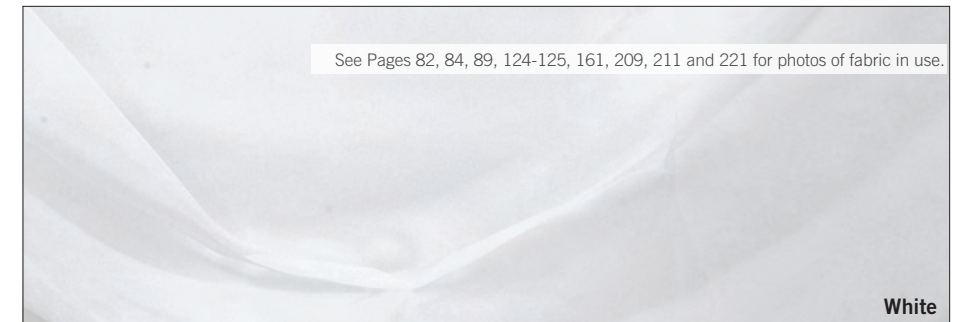

### SHIMMER VOILE

**Inherently Flame Retardant.** Trevira®. Charcoal/Silver. Lighting will turn this versatile sheer from dark to shimmering and from translucent to transparent.

Roll = Approx. 76 yds.

	Price Per Yard	
	Cut	Full Roll
118" IFR	30.00	20.00

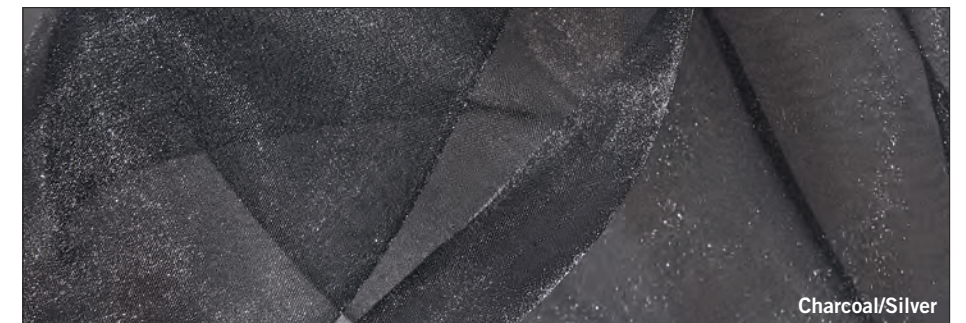

### SILVER SHIMMER VOILE

**Inherently Flame Retardant.** A more reflective and economical Shimmer Voile, in a smoky shade of Silver.

Roll = Approx. 100 yds.

	Price Per Yard	
	Cut	Full Roll
118" IFR	18.00	12.00

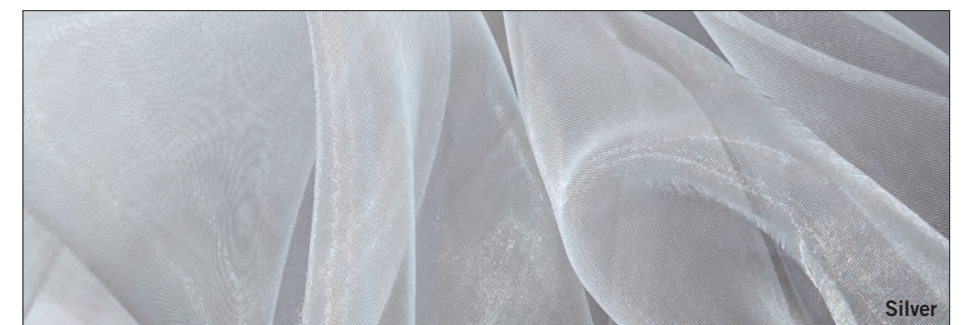

- Fabrics
- Black Masking
- Custom Stage Curtains & Backdrops
- Custom Special Event Sewing
- Digital Printing
- LED Star Drops
- Pipe & Base
- Rentals
- Projection Materials
- Flooring
- Curtain Track
- Stage Equipment, FXs & Mirrors
- DMX Winches
- Scenery Props
- Shop & Production Supplies
- Tape
- Film & Video Supplies
- Index





Stephen Burrows

Product: Voile; Stephen Burrows: *When Fashion Danced*; Museum of the City of New York; Photo: C. Bay Millin Photography

**CRYSTAL**

**Inherently Flame Retardant.** Translucent Crystal shimmers in our pick of the most glamorous jewel tones. Then we turn up the volume with our embossed version of this eye-catching fabric.

Roll = Approx. 50-60 yds.

	Price Per Yard	
	Cut	Full Roll
58/60" <b>IFR</b>	9.50	7.60

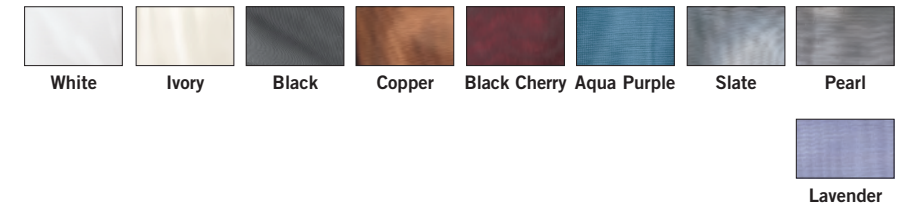

**EMBOSSED CRYSTAL**

**Inherently Flame Retardant.** An arrestingly beautiful version of our crystal fabric that shows variable depth and contours.

Roll = 50-80 yds.

	Price Per Yard	
	Cut	Full Roll
42" <b>IFR</b>	12.50	10.00

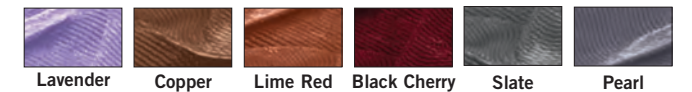

**Buy or Rent**

**SHIMMER ORGANZA**

**Flame Retardant.** 100% Polyester. Iridescence provides brilliant color shifts as it plays to the audience. **FR** with sparkle, in colors designed as a companion to our Taffeta (see page 108).

Roll = Approx. 50-70 yds.

	Price Per Yard	
	Cut	Full Roll
118" <b>FR</b>	15.47	12.35

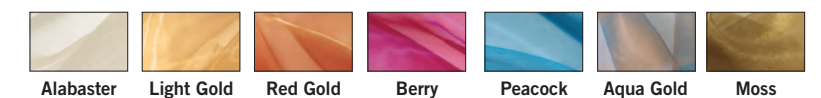

- Fabrics
- Black Masking
- Custom Stage Curtains & Backdrops
- Custom Special Event Sewing
- Digital Printing
- LED Star Drops
- Pipe & Base
- Rentals
- Projection Materials
- Flooring
- Curtain Track
- Stage Equipment, FXs & Mirrors
- DMX Winches
- Scenery Props
- Shop & Production Supplies
- Tape
- Film & Video Supplies
- Index



Sheer



See Page 87 for photo of fabric in use.



**ORGANDY**

**Flame Retardant.** This bargain sheer comes in a wonderful color palette that ranges from understated to striking.  
Roll = Approx. 50 yds.

	Price Per Yard	
	Cut	Full Roll
58"-60" <b>FR</b>	6.75	4.50



Product: Organdy; *Glitch*; Illuminus: Nuit Blanche – Boston, MA; Designer: Sam Okerstrom-Lang; Scene Shop: Gallery 2; Photo: Ho Yin Au

All Rose Brand Flame Retardant Fabrics Pass NFPA 701 testing. See RoseBrand.com for additional FR standards and registration numbers.

- Fabrics
- Black Masking
- Custom Stage Curtains & Backdrops
- Custom Special Event Sewing
- Digital Printing
- LED Star Drops
- Pipe & Base
- Rentals
- Projection Materials
- Flooring
- Curtain Track
- Stage Equipment, FXs & Mirrors
- DMX Winches
- Scenery Props
- Shop & Production Supplies
- Tape
- Film & Video Supplies
- Index



## Sheer

See Pages 161, 163 and 205 for photos of fabric in use.

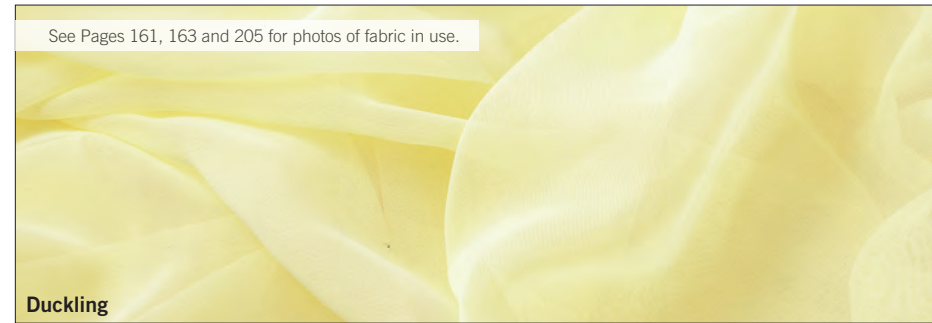

Duckling



### CHIFFON

Can be made **Flame Retardant**. Lightweight polyester. Transparent sheer. Used as reveals for industrials, theater, dance and nightclubs. (Allow 1 week for **FR** treatment for colors. Full roll minimum.) Must be ordered in 25 yds. increments.

Roll = Approx. 50 yds.

	Price Per Yard	
	Cut	Full Roll
60" NFR Black, White, Ivory	6.96	5.35
60" <b>FR</b> Black, White, Ivory	10.11	8.35
60" NFR Colors	6.96	5.35
60" <b>FR</b> Colors	10.11	8.35

**FR Chiffon in Black, White, and Ivory in stock and ready to ship!**



Crystal Grey



### ICICLE

**Flame Retardant**. Sheer. 100% Polyester Icicle fabric has a lustrous but subtle sheen.

Roll = Approx. 50 yds.

	Price Per Yard	
	Cut	Full Roll
58" <b>FR</b>	10.50	7.00



Products: Voile, Poly Cyc; *Oscar de la Renta: The Retrospective*, de Young Museum; Photo: Courtesy of Fine Arts Museums of San Francisco



**ANY EVENT  
AT ANY BUDGET!  
ROSE BRAND  
IS YOUR EVENT  
PLANNING  
PARTNER**



Product: Custom Sheer Fabric, Keder Rail and Installation; Metropolitan Museum of Art; Like Life: Sculpture, Color, and the Body at The Met Breuer; Photo: Louis Peter



Product: Custom Sheer Fabric, Keder Rail and Installation; Metropolitan Museum of Art; Like Life: Sculpture, Color, and the Body at The Met Breuer; Photo: Louis Peter

**Sheer**

**SERENO**

**Inherently Flame Retardant.** A lovely sheer with cloudy transparency and just enough texture and body to make it great for lighting and projection. At 13'3" wide and at this price, economy is built into the fabric so you don't have to make cuts in your design.

Roll = Approx. 100 yds.

	Price Per Yard	
	Cut	Full Roll
13'3" <b>IFR</b>	10.50	7.00

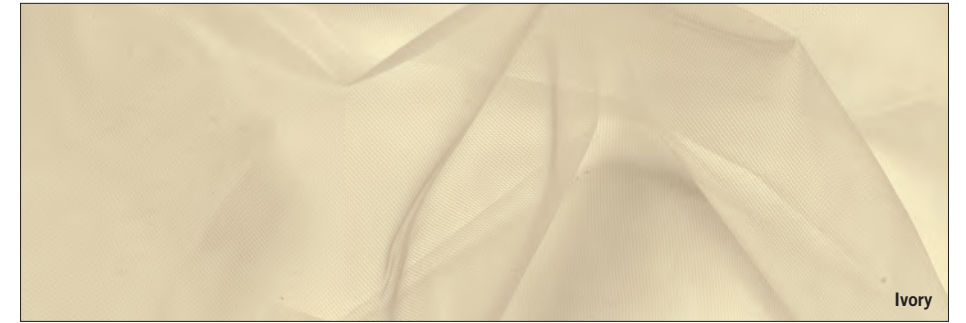

Ivory



White

**BATISTE**

**Inherently Flame Retardant.** 100% Polyester. Lightweight and semi-transparent with slightly more body and texture than Voile. Retains an airy softness.

Roll = Approx. 65 yds.

	Price Per Yard		
	Cut	Full Roll	500+ Yds*
118" <b>IFR</b>	8.25	5.50	4.25

**VOLUME DISCOUNT**

\*Must be Purchased in Full Roll/Piece Increments.

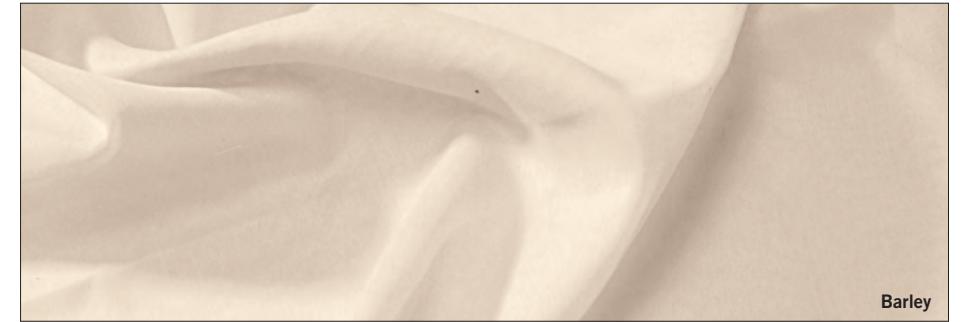

Barley



White



Silver

**CRUSHED VOILE**

**Inherently Flame Retardant.** Polyester. The crushed version of our lightweight, semi-transparent **IFR** Voile has a texture that catches and bounces more light. Excellent for indoor and outdoor draping of tents and events. 100% Polyester. Wide width comes half-folded and rolled for shipping.

Roll = Approx. 50-65 yds.

	Price Per Yard	
	Cut	Full Roll
114" <b>IFR</b>	13.50	9.00

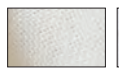

Oyster

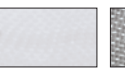

White

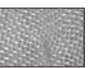

Silver

- Fabrics
- Black Masking
- Custom Stage Curtains & Backdrops
- Custom Special Event Sewing
- Digital Printing
- LED Star Drops
- Pipe & Base
- Rentals
- Projection Materials
- Flooring
- Curtain Track
- Stage Equipment, FXs & Mirrors
- DMX Winches
- Scenery Props
- Shop & Production Supplies
- Tape
- Film & Video Supplies
- Index



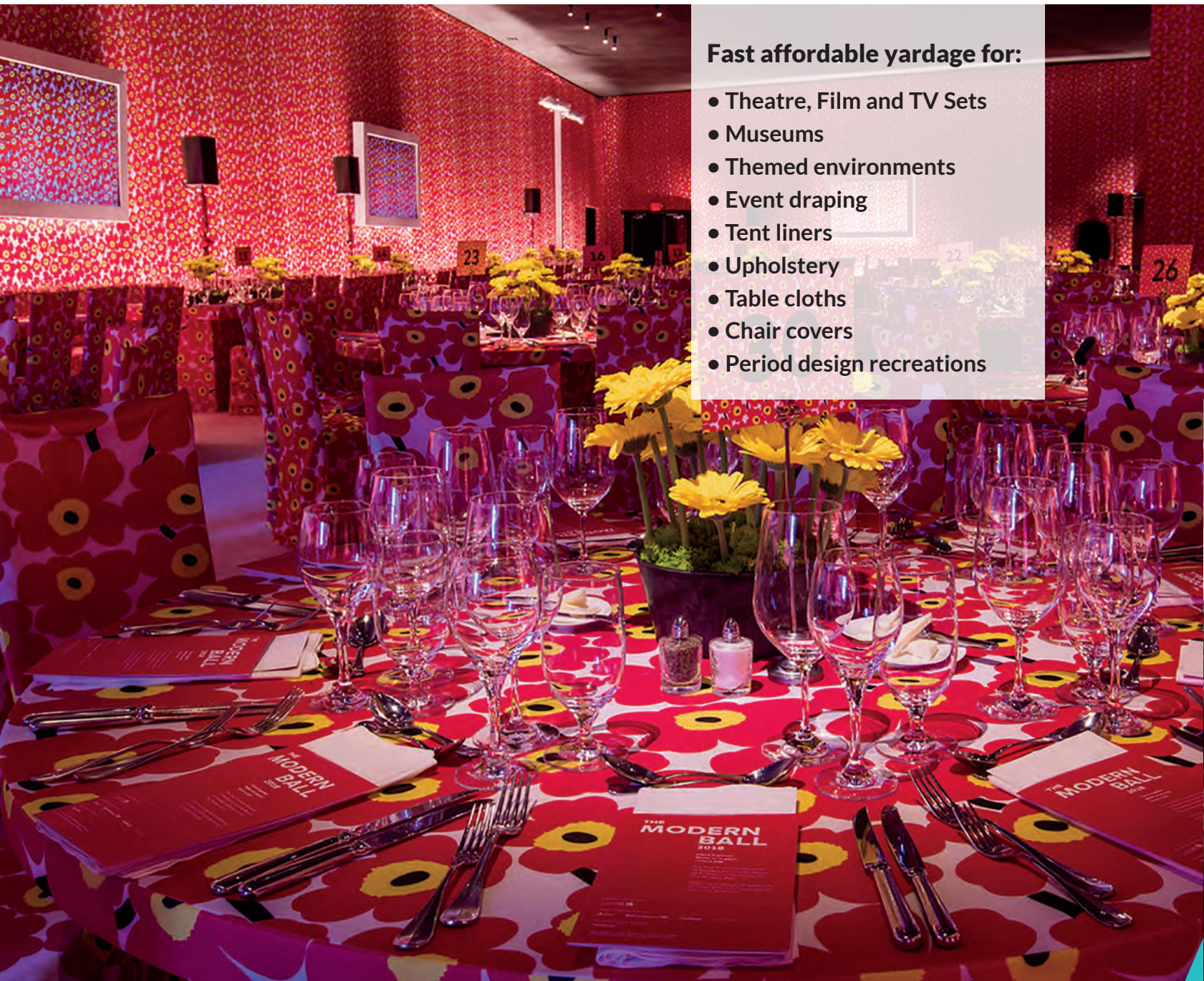

**Fast affordable yardage for:**

- Theatre, Film and TV Sets
- Museums
- Themed environments
- Event draping
- Tent liners
- Upholstery
- Table cloths
- Chair covers
- Period design recreations

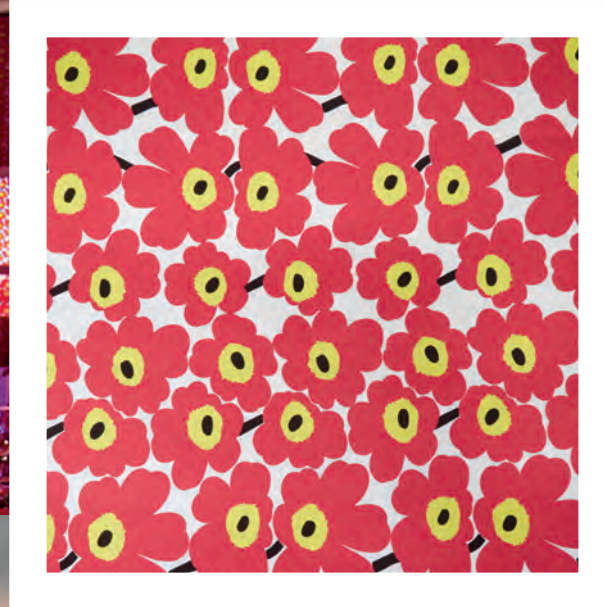

Beautiful custom repeat pattern printing on FR fabric is now available by the yard. A great solution for creating new fabric designs or recreating the look of classic period designs without the long lead times and expense of custom weaving.

The minimum is 100 yards and turnaround times can be as little as 2 weeks after the confirmation of print ready art work.

36" vertical repeats are standard and larger repeats are possible depending on the actual design.

Contact us for pricing as price per yard varies greatly with quantity.

**Available in a selection of fabrics in widths from 60" to 120"**

- Heavy Knit
- Poly Duck Canvas
- Poly Silk
- Stretch Knit
- Poly Sheer
- Flag Cloth
- Gaming Suede

Product: Custom digitally printed fabric; Event: San Francisco Museum of Modern Art (SFMOMA) 2018 Modern Ball; Designer: Stanlee R. Gatti Designs; Lighting: Got Light; Installation: Bright Event Rentals; Production: GB Event Productions; Photographer: Mekenna DeBack of Stanlee R. Gatti Designs

- Fabrics
- Black Masking
- Custom Stage Curtains & Backdrops
- Custom Special Event Sewing
- Digital Printing
- LED Star Drops
- Pipe & Base
- Rentals
- Projection Materials
- Flooring
- Curtain Track
- Stage Equipment, FXs & Mirrors
- DMX Winches
- Scenery Props
- Shop & Production Supplies
- Tape
- Film & Video Supplies
- Index





Product: Poly Silk; *Shahrazad*, Royal Ballet of Flanders; Scenic and Lighting Designer: Aaron Copp; Choreography and Direction: Jonah Bokaer; Costume Designer: Azzedine Alaia; Photo: © Filip Van Roe for Royal Ballet of Flanders

## DID YOU KNOW?

### One of the most popular Silk effects is the Flutter Drop.

Usually deployed and released by a Kabuki mechanism, the lightweight Silk billows and flutters dramatically down to the deck.

The ideal Silk to use is real China Silk, see page 97.

Poly Silk and Allegro are acceptable substitutes when budgets are tight.

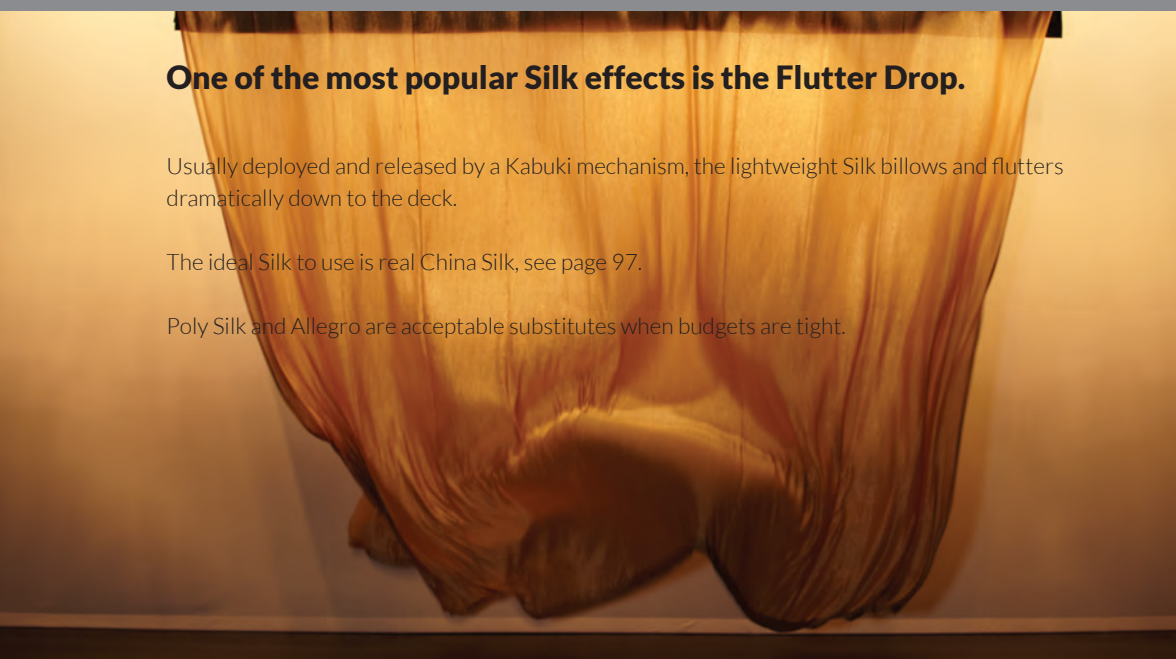

### POLY SILK

**Flame Retardant.** A stand-in for real silk, this economical, soft flowing fabric has a phenomenal range of 32 colors. Graceful and fluid describe any draping done with this material.

Roll = Approx. 50 yds.

	Price Per Yard		
	Cut	Full Roll	500+Yds*
60" <b>FR</b> White & Black	5.75	3.50	2.95
60" <b>FR</b> Colors	7.50	4.50	3.75

#### VOLUME DISCOUNT

\*Must be Purchased in Full Roll/Piece Increments.

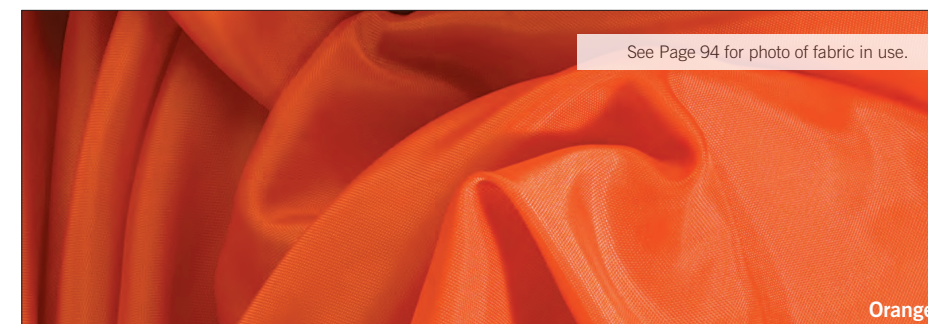

### 119" ALLEGRO SILK

**Inherently Flame Retardant.** The perfect extra-wide poly silk surface for projection, diffusion, and lighting. Translucent, soft, and economical.

Roll = Approx. 65 yds.

	Price Per Yard		
	Cut	Full Roll	500+ Yds*
119" <b>IFR</b>	14.65	9.75	7.75

#### VOLUME DISCOUNT

\*Must be Purchased in Full Roll/Piece Increments.

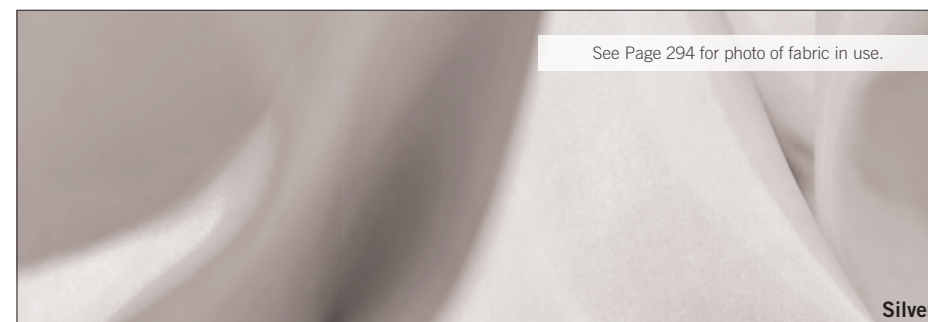

### 16' 6" WHITE SUPERSILK

**Inherently Flame Retardant.** Magnificent at 16' 6", the high quality of this Trevira® CS poly-silk makes it a superior choice for draping large areas and seamless projections. Washable for a long, useful life.

Piece = Approx. 65 yds.

	Price Per Yard		
	Cut	Full Roll	500+ Yds*
16'6" <b>IFR</b>	30.80	22.00	19.25

#### VOLUME DISCOUNT

\*Must be Purchased in Full Roll/Piece Increments.

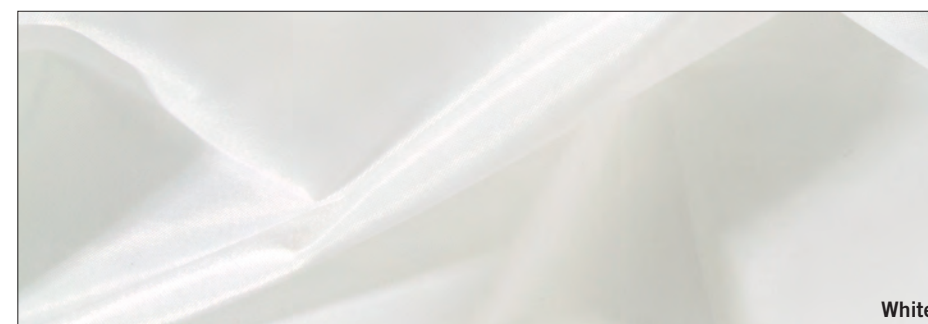



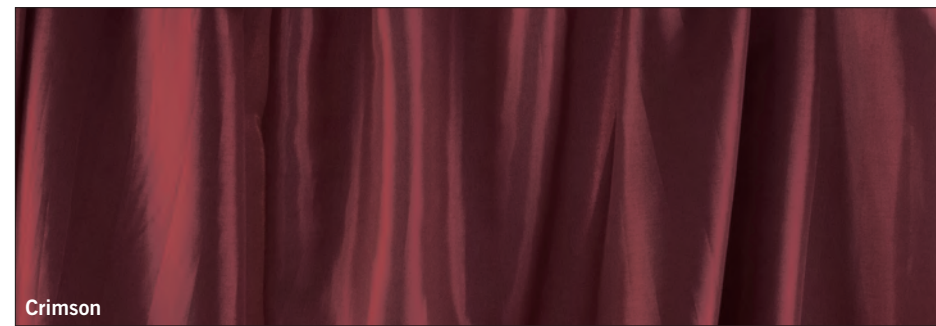

Crimson



**TREVIRA® SILK**

**Inherently Flame Retardant.** The shimmer for which silk is prized comes from the fibers' prism-like structure which refracts incoming light at different angles. Our shimmering Trevira® silk has the look and feel of real silk with the added bonus of minimum care and crease resistance.

Roll = Approx. 60 yds.

58" IFR	Price Per Yard	
	Cut	Full Roll
	6.50	5.00



Beige (Crushed)

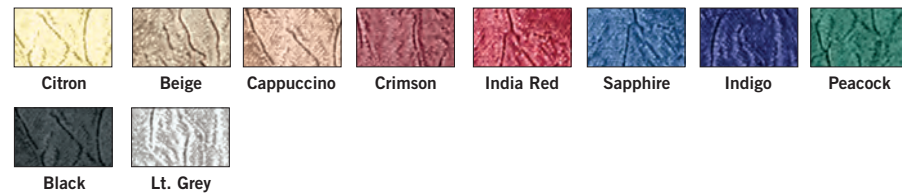

Buy or Rent

**CRUSHED TREVIRA® SILK**

**Inherently Flame Retardant.** The same shimmery quality as our Trevira® silk, but with a crushed texture that provides greater depth.

Roll = Approx. 60-70 yds.

52" IFR	Price Per Yard	
	Cut	Full Roll
	7.80	6.00

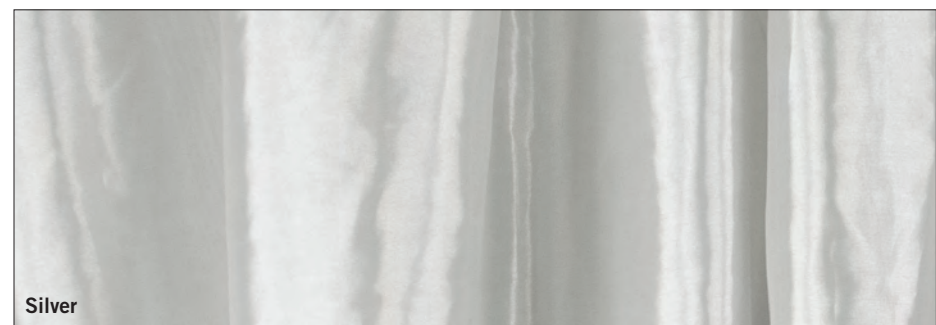

Silver

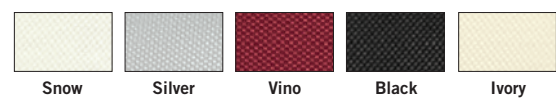

**IMPRESSION**

**Inherently Flame Retardant.** This lightweight polyester silk drapes brilliantly and has a soft sheen and feel. Subtle colors for elegant events.

Roll = Approx. 45-70 yds.

118" IFR	Price Per Yard	
	Cut	Full Roll
	11.20	8.00

Black and White no minimum; all other colors 10 yard minimum.

**CHINA SILK**

**Can be made Flame Retardant.** 100% Natural imported silk. Lightweight. Translucent. Drapes beautifully. 54" is a heavier weight. (Allow 1 week for FR treatment. Full roll minimum for colors.)

Roll = Approx. 50 yds.  
NFR Minimum 10 yds.  
FR Minimum 50 yds.

	Price Per Yard	
	Cut	Full Roll
45" NFR	20.55	16.45
45" FR	23.55	19.45
54" NFR Black, White	15.65	12.50
54" FR Black, White	18.65	15.50

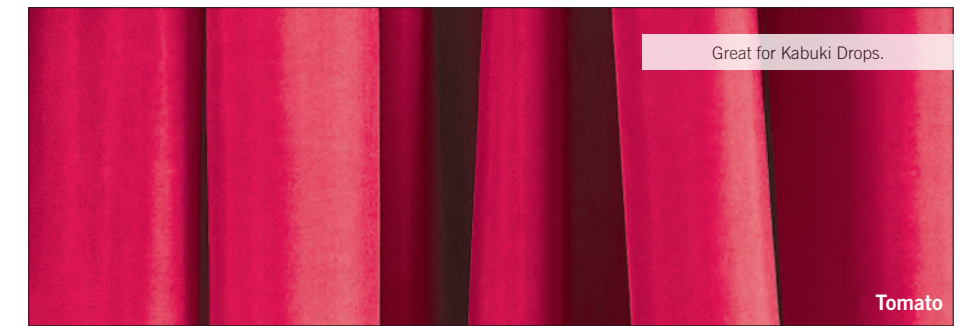

Great for Kabuki Drops.

Tomato



**BIJOU**

**Inherently Flame Retardant.** 100% Polyester. Elegant faux raw silk with a slight sheen and a slubbed texture.

Roll = Approx. 50-70 yds.

54" IFR	Price Per Yard	
	Cut	Full Roll
	15.47	12.35

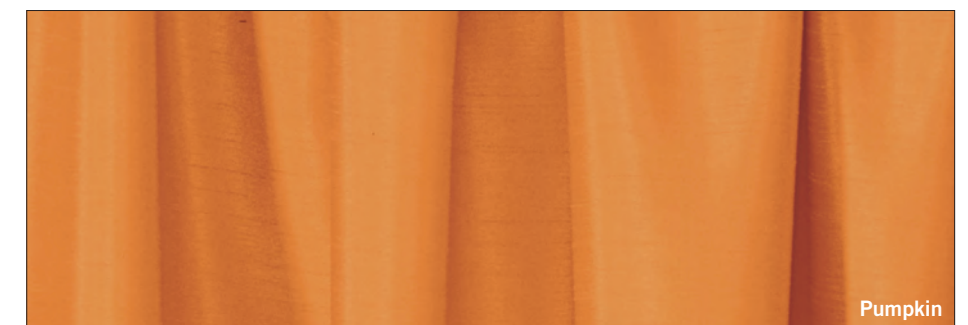

Pumpkin



**POLYANNA**

**Inherently Flame Retardant.** An economical artificial silk that's great for dressing event spaces or lining stage curtains.

Roll = Approx. 60-90 yds.

54" IFR	Price Per Yard	
	Cut	Full Roll
	6.82	5.25



White





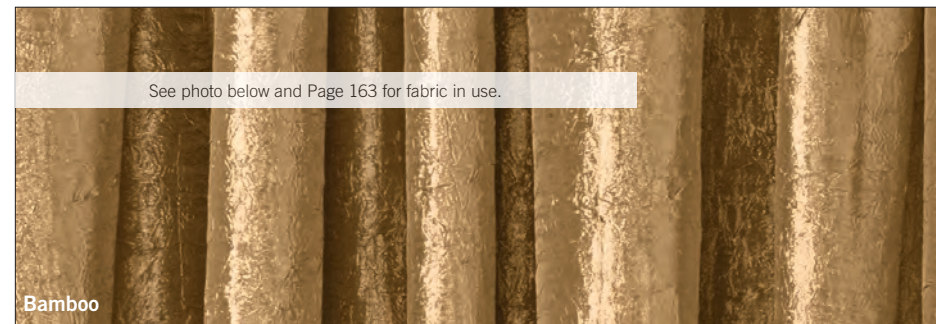

See photo below and Page 163 for fabric in use.



Most Popular! | Buy or Rent

**TERGALET**

**Inherently Flame Retardant.** Crushed, lightweight 100% polyester silk available in a jewel tone palette. Wide width and soft hand allows this fabric to drape beautifully for a rich look.

Roll = Approx. 50-70 yds.

	Price Per Yard		
	Cut	Full Roll	500+ Yds*
106" <b>IFR</b>	16.50	11.00	9.35

**VOLUME DISCOUNT**

\*Must be Purchased in Full Roll/Piece Increments.

**ELEGANCE**

**Flame Retardant.** Lustrous, iridescent, shimmer fabric with good drapability. Lights beautifully. Ideal for stage draperies and special events.

Roll = Approx. 50 yds.

	Price Per Yard	
	Cut	Full Roll
58" <b>FR</b>	13.37	9.90

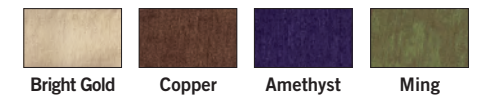
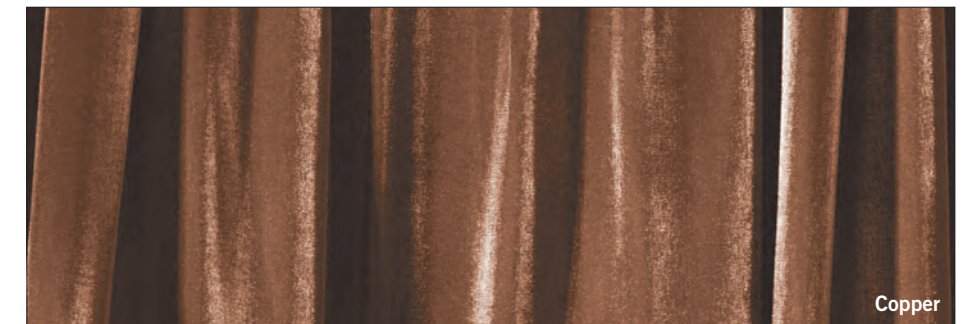

Products: Ivory and Silver Tergalet, Nathaniel Rateliff and the Night Sweats - Tearing at the Seams Tour, Designer: Jeremy Roth, Photo: Jeremy Roth

**CRUSHED ELEGANCE**

**Flame Retardant.** As wonderfully lustrous and iridescent as Elegance shown above, with an added textural quality that provides greater visual interest and hides creases.

Roll = Approx. 50 yds.

	Price Per Yard	
	Cut	Full Roll
55" <b>FR</b>	9.10	7.00

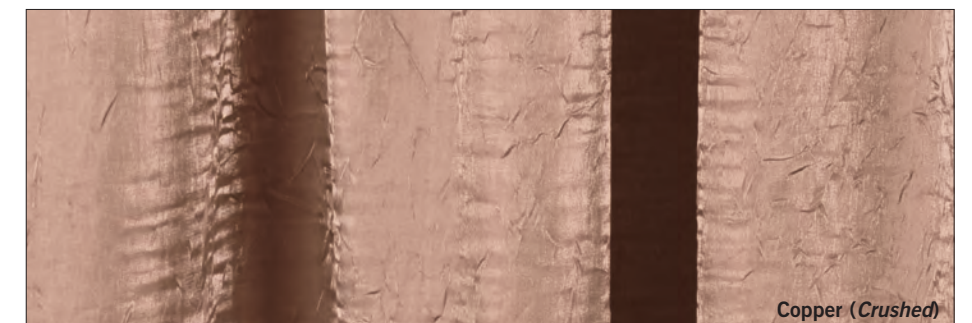

**ORIENT**

**Inherently Flame Retardant.** 100% Polyester. Elegant faux raw silk with a slight sheen and a slubbed texture.

Roll = Approx. 60 yds.

	Price Per Yard	
	Cut	Full Roll
54" <b>IFR</b>	10.25	8.20

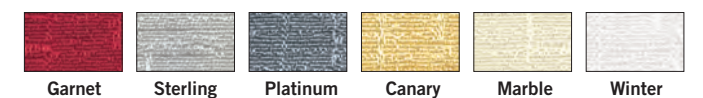





# Eliza

**ELIZA** NEW

**Inherently Flame Retardant.** With a range of 34 vibrant colors this versatile fabric has the rich texture of dupioni silk at a fraction of the cost.

Roll = Approx. 100 yds.

	Price Per Yard	
	Cut	Full Roll
60" <b>IFR</b>	8.25	5.50



- Fabrics
- Black Masking
- Custom Stage Curtains & Backdrops
- Custom Special Event Sewing
- Digital Printing
- LED Star Drops
- Pipe & Base
- Rentals
- Projection Materials
- Flooring
- Curtain Track
- Stage Equipment, FXs & Mirrors
- DMX Winches
- Scenery Props
- Shop & Production Supplies
- Tape
- Film & Video Supplies
- Index



## Satin

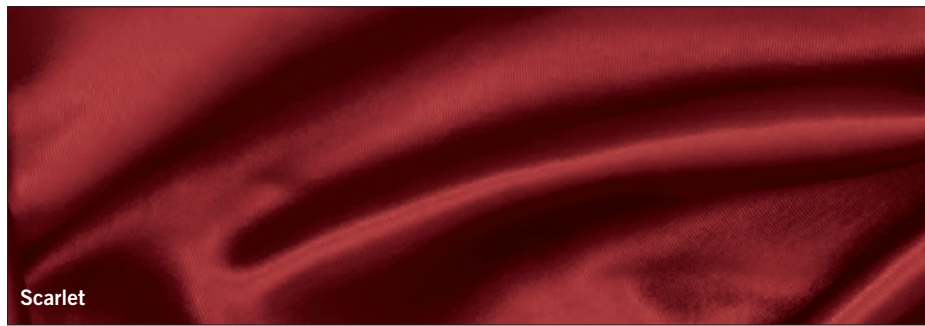

Scarlet



### ECLIPSE SATIN

**Inherently Flame Retardant.** Top quality, blackout satin. Woven with a special black microfiber that creates dimensional brilliance!

Roll = Approx. 40-50 yds.

		Price Per Yard	
		Cut	Full Roll
58"	<b>IFR</b>	16.50	11.00



Bullion Gold



Buy or Rent

### CRUSHED GLOSS SATIN

**Inherently Flame Retardant.** Rich and glossy, with textural highlights that catch light and add depth magnificently.

Roll = Approx. 50 yds.

		Price Per Yard	
		Cut	Full Roll
50"/52"	<b>IFR</b>	13.50	9.00

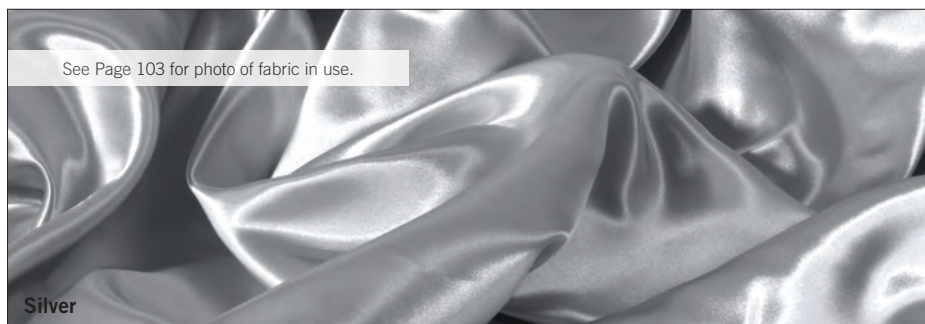

See Page 103 for photo of fabric in use.

Silver



### GLOSS SATIN

**Inherently Flame Retardant.** Soft and shimmering lightweight satin in saturated colors that make a bold statement.

Roll = Approx. 50 yds.

		Price Per Yard	
		Cut	Full Roll
58"	<b>IFR</b>	11.40	7.60



Product: Paladin, Gloss Satin; *Christmas from the Heart*, Stanleyville Theater at Busch Gardens Tampa Bay

All Rose Brand Flame Resistant Fabrics Pass NFPA 701 testing. See RoseBrand.com for additional FR standards and registration numbers.

- Fabrics
- Black Masking
- Custom Stage Curtains & Backdrops
- Custom Special Event Sewing
- Digital Printing
- LED Star Drops
- Pipe & Base
- Rentals
- Projection Materials
- Flooring
- Curtain Track
- Stage Equipment, FXs & Mirrors
- DMX Winches
- Scenery Props
- Shop & Production Supplies
- Tape
- Film & Video Supplies
- Index



Satin



**AUGUSTA**

**Inherently Flame Retardant.** An elegant lightweight wide width crushed satin with a subtle shimmer that lights and drapes beautifully. Reversible with the backside offering a crushed non-shimmering texture for lighting moments that require a matte surface.

Roll = Approx. 40-50 yds.

**Price Per Yard**

	Cut	Full Roll	500+ Yds*
106" <b>IFR</b>	16.50	11.00	9.00

**VOLUME DISCOUNT**

\*Must be Purchased in Full Roll/Piece Increments.



Satin



**CHARM**

**Inherently Flame Retardant.** A reversible wide width satin with a medium sheen on one side and a more matte finish on the reverse. The biggest bang for buck of any of the satins in terms of cost per square foot of coverage. In 11 designer colors, including many subtle neutral tones.

Roll = Approx. 60 yds.

**Price Per Yard**

	Cut	Full Roll
118" <b>IFR</b>	10.00	8.00

Fabrics

- Black Masking
- Custom Stage Curtains & Backdrops
- Custom Special Event Sewing
- Digital Printing
- LED Star Drops
- Pipe & Base
- Rentals
- Projection Materials
- Flooring
- Curtain Track
- Stage Equipment, FXs & Mirrors
- DMX Winches
- Scenery Props
- Shop & Production Supplies
- Tape
- Film & Video Supplies
- Index



# Jubilee Satin



AVAILABLE  
IN  
62  
COLORS

## JUBILEE SATIN

**Inherently Flame Retardant.** An affordable event satin in every color you might need. A soft drape and gentle sheen add class to your party or event decorations.

Roll = Approx. 100 yds.

### Price Per Yard

	Cut	Full Roll	500+ Yds*
59"-60" IFR	6.75	4.50	3.75

### VOLUME DISCOUNT

\*Must be Purchased in Full Roll/Piece Increments.



- Fabrics
- Black Masking
- Custom Stage Curtains & Backdrops
- Custom Special Event Sewing
- Digital Printing
- LED Star Drops
- Pipe & Base
- Rentals
- Projection Materials
- Flooring
- Curtain Track
- Stage Equipment, FXs & Mirrors
- DMX Winches
- Scenery Props
- Shop & Production Supplies
- Tape
- Film & Video Supplies
- Index



# Satin

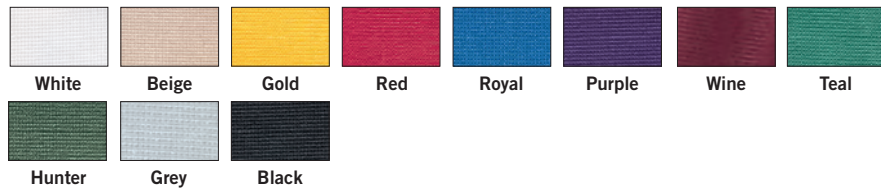

## POLY SHEEN

**Inherently Flame Retardant.** When budget driven, choose this economical medium weight synthetic satin fabric. It drapes beautifully and has excellent light reflection properties. Sturdy and washable, this fabric can be reused.

Roll = Approx. 125-150 yds.

		Price Per Yard		
		Cut	Full Roll	500+ Yds*
41"	<b>IFR</b>	5.25	3.50	2.50

### VOLUME DISCOUNT

\*Must be Purchased in Full Roll/Piece Increments.

		Price Per Yard	
		Cut	Full Roll
120"	<b>IFR</b> White, Black	10.94	8.75

# Satin

## DRIZZLE

**Flame Retardant.** We have put together the combination of multi-texture and free form pinstripes to create a new look for satin. The distinctive color palette is perfect when you need to make a WOW statement!

Roll = Approx. 50 yds.

		Price Per Yard	
		Cut	Full Roll
58"	<b>FR</b>	11.40	7.60

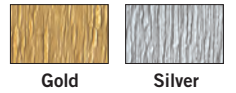

## TAFFETA

**Inherently Flame Retardant.** 100% Polyester. Our slightly iridescent Taffeta communicates sophistication, elegance, and excitement.

Roll = Approx. 50-70 yds.

		Price Per Yard	
		Cut	Full Roll
54"	<b>IFR</b>	14.70	9.80

## RADIANCE

**Flame Retardant.** Superior draping and a classic color palette in 100% polyester make this synthetic satin an excellent choice for tent decorating. Wide width at 120".

Roll = Approx. 100-120 yds.

		Price Per Yard	
		Cut	Full Roll
120"	<b>FR</b>	11.25	7.50

Colors: White, Black.

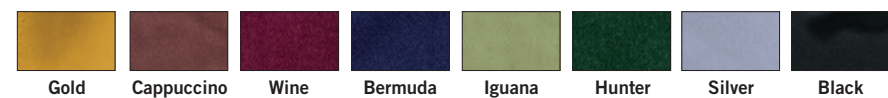
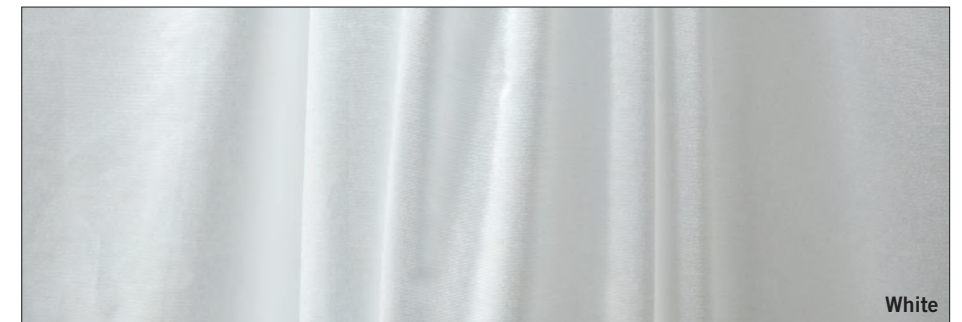

## BLACKOUT SATIN

**Inherently Flame Retardant.** Totally opaque but soft and medium weight, Blackout Satin is ideal for applications that call for total light block without a lining. Great for Austrians and Swags.

Roll = Approx. 50 yds.

		Price Per Yard		
		Cut	Full Roll	500+ Yds*
58"	<b>IFR</b>	13.50	9.00	7.50

### VOLUME DISCOUNT

\*Must be Purchased in Full Roll/Piece Increments.

## ALYSSA

**Inherently Flame Retardant.** This antique satin fabric does double duty with one side matte and the reverse side glossy. An interior classic palette of colors make this a great choice for permanent installations.

Roll = Approx. 85-100 yds.

		Price Per Yard	
		Cut	Full Roll
56"	<b>IFR</b>	15.39	11.80

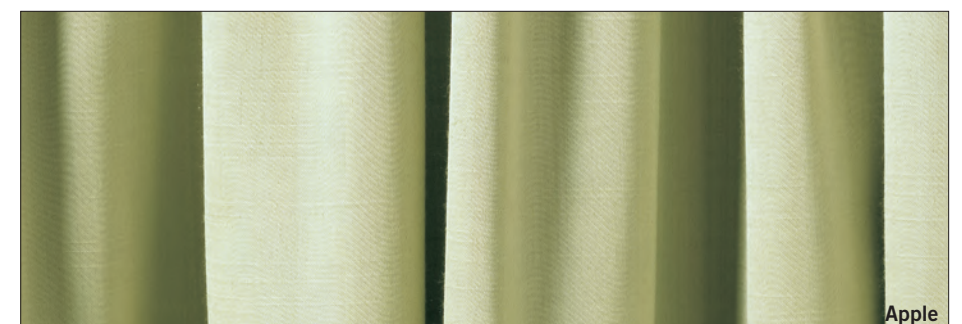





Product: Tendo, Liquid Metal, Encore: *The Diner* by David Rockwell + Surface with 2x4; Design Concept: David Rockwell and the LAB at Rockwell Group; Graphic Identity: 2x4; Drapery Produced and Provided by: ShowMotion Inc.

**PALADIN**

**Flame Retardant.** Polyester. Antique effects and versatility describe our Poly Shantung fabric. A satin sheen with a nubby dark striation on one side, and a smooth, complementary, lustrous sheen on the other. This is an excellent flame retardant display fabric.

Roll = Approx. 50 yds.

58" FR	Price Per Yard	
	Cut	Full Roll
	10.50	7.00

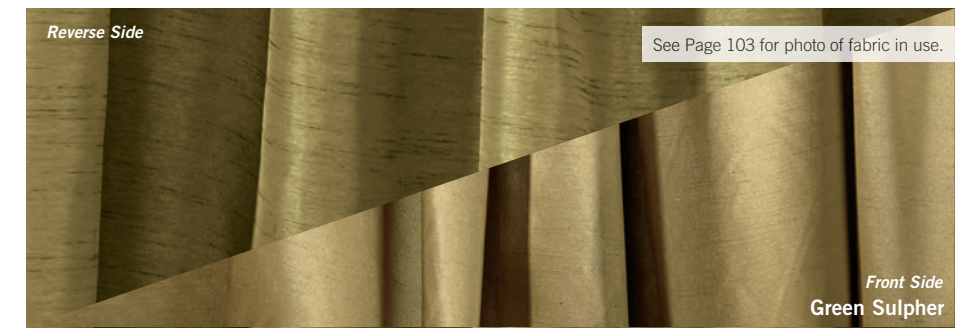

**PINEHURST**

**Inherently Flame Retardant.** A vintage look with a tone on tone stubby texture, combined with a matte finish, make this an excellent interior drapery fabric. A soft classic choice of earth-tone colors.

Roll = Approx. 65-75 yds.

54" IFR	Price Per Yard	
	Cut	Full Roll
	17.75	11.85

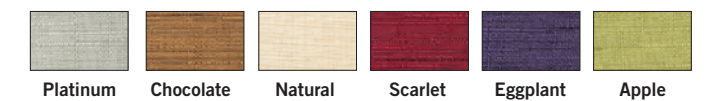

**FIRECRACKER**

**Flame Retardant.** Gold luminous highlights define this flame retardant polyester fabric. The rich sheen of the earth-tone palette make this fabric an excellent budget choice for draping and accent pieces.

Roll = Approx. 50 yds.

58" FR	Price Per Yard	
	Cut	Full Piece
	14.85	9.90

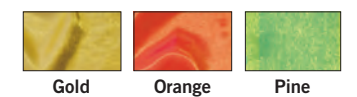
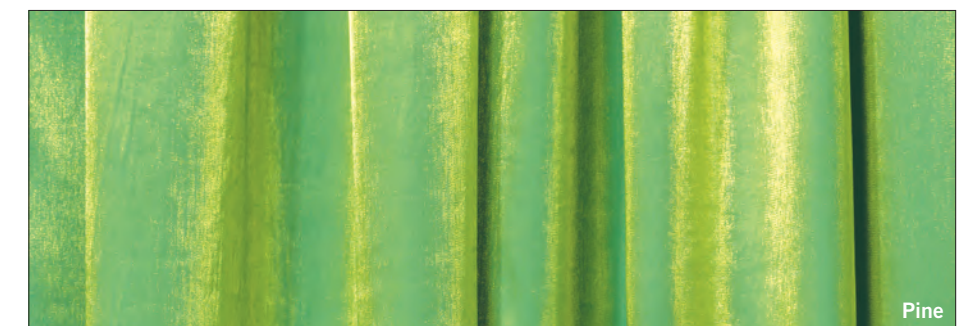



# Metallic

## SIZZLE

**Flame Retardant.** It doesn't get glitzier than Sizzle when it comes to metallic fabrics. This lightweight knit dazzles in 7 vibrant colors.

Roll = Approx 33 yds.

44" <b>FR</b>	Price Per Yard	
	Cut	Full Roll
	21.00	14.00



## MULTI SIZZLE

**Flame Retardant.** Multi Sizzle seems to move even when it's standing still. Multi color combos of metallic thread create a great shimmering effect.

Roll = Approx 33 yds.

44" <b>FR</b>	Price Per Yard	
	Cut	Full Roll
	22.50	15.00

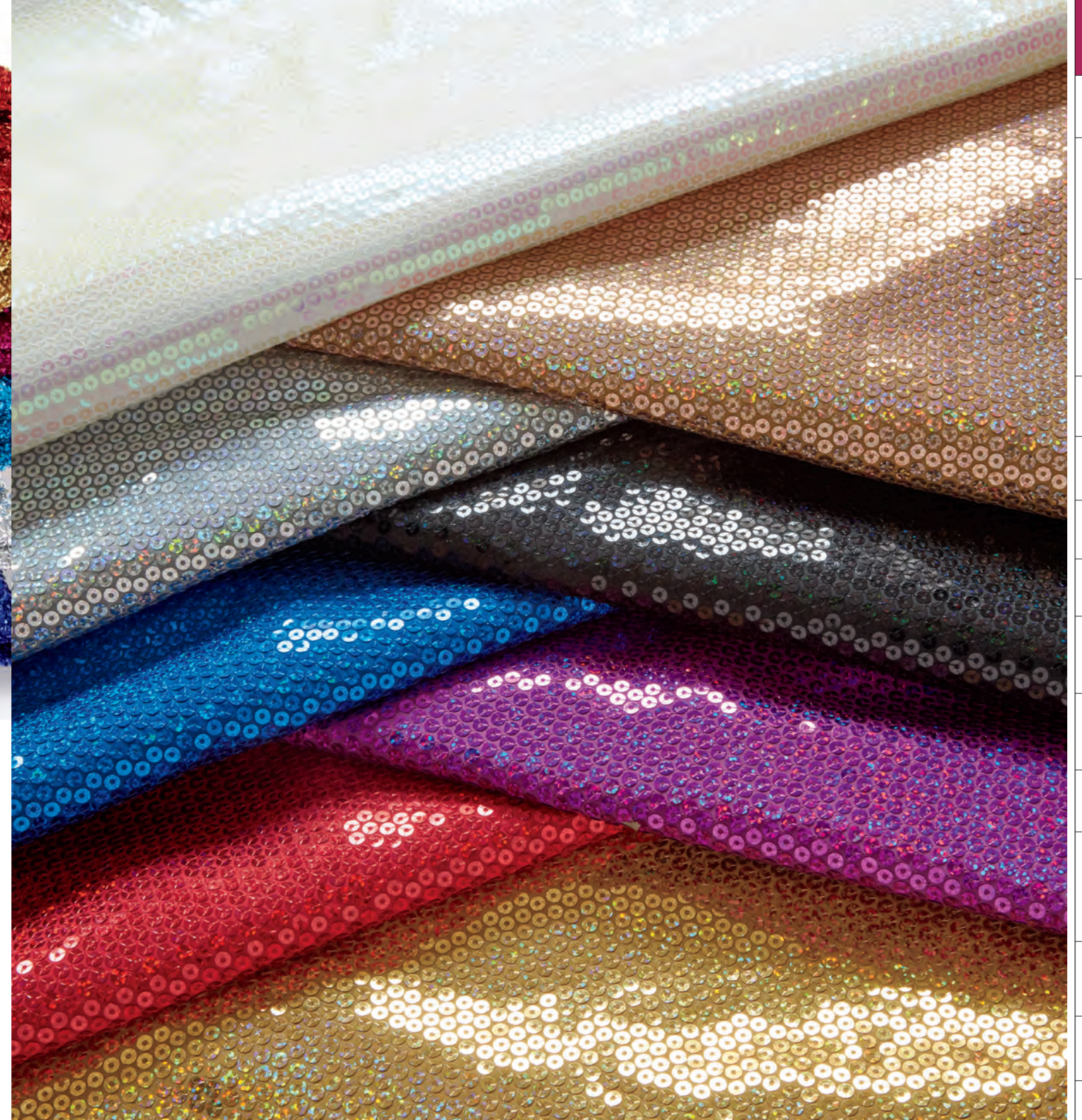
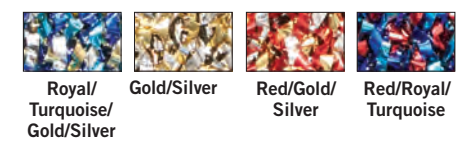

## SPARKLER

**Flame Retardant.** Luxurious, iridescent sequined fabric in a wide palette of colors. Rich, tight sequin placement will make a bright splash of color and sparkle at your next event.

Roll = Approx 100 yds.

53"	NFR	Price Per Yard	
		Cut	Full Roll
53"	<b>FR</b>	22.50	15.00
53"	<b>FR</b>	25.50	18.00

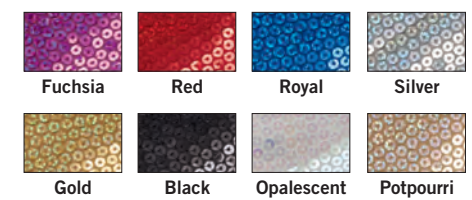

- Fabrics
- Black Masking
- Custom Stage Curtains & Backdrops
- Custom Special Event Sewing
- Digital Printing
- LED Star Drops
- Pipe & Base
- Rentals
- Projection Materials
- Flooring
- Curtain Track
- Stage Equipment, FEs & Mirrors
- DMX Winches
- Scenery Props
- Shop & Production Supplies
- Tape
- Film & Video Supplies
- Index





Product: Black/Gold Domino; *Guys and Dolls*, Finger Lakes Musical Theatre Festival; Designer: Shoko Kambara; Scene Shop: Finger Lakes Musical Theatre Festival; Photo: Shoko Kambara

## Metallic

### CHEVY METAL

**Flame Retardant.** Handsome lightweight knit with a chevron pattern, has the look of chain mail. Neutral Silver lights to any color.

Roll = Approx. 50-56 yds.

	Price Per Yard	
	Cut	Full Roll
51" NFR	12.00	8.00
51" <b>FR</b>	18.00	12.00

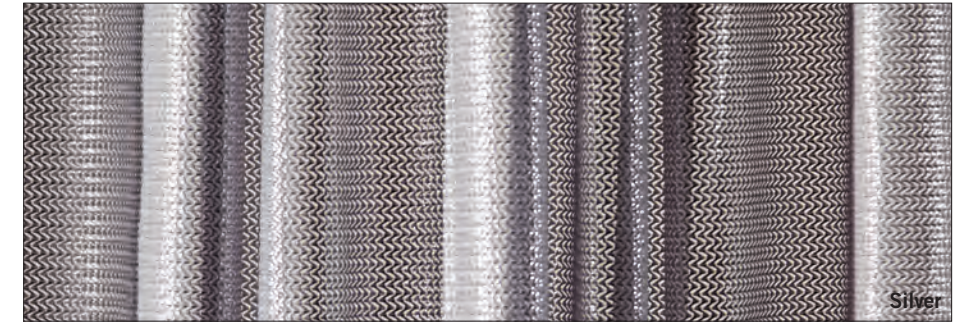

### MIRAGE

**Flame Retardant.** A wide metallic sheer that is made for lighting effects. When front lit, the sparkle pops out fading to a semi-transparent, textured weave as it bleeds through.

Roll = Approx. 40-50 yds.

	Price Per Yard	
	Cut	Full Roll
118" <b>FR</b>	21.00	14.00



### Buy or Rent

#### DOMINO

**Flame Retardant.** 100% Polyester. Knitted and slinky, this fabric has black or white warp embellished with metallic face threads railroaded on the surface. It gives the illusion of depth and texture. With a soft hand, this fabric is reversible and excellent for draping and swagging treatments.

Roll = Approx. 100 yds.

	Price Per Yard	
	Cut	Full Roll
62" <b>FR</b>	14.85	9.90

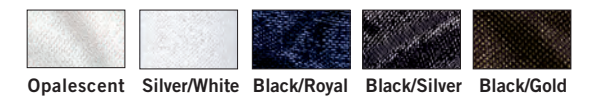



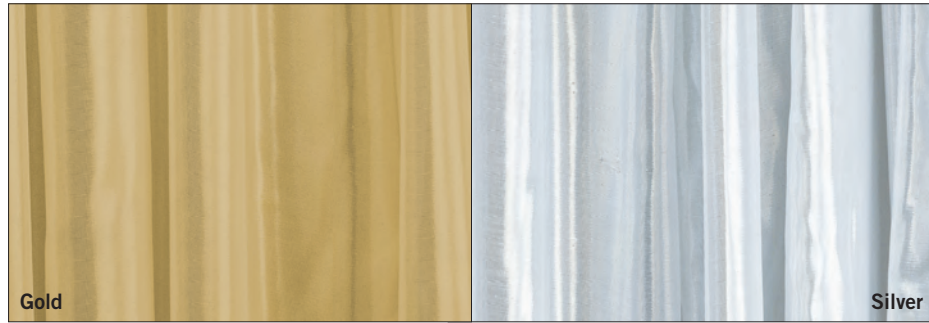

**LUREX SHEER**

**Inherently Flame Retardant.** Lightweight, translucent metallic with a lustrous sheen. Can be folded to ship.

Roll = Approx. 110 yds.

118" <b>IFR</b>	Price Per Yard	
	Cut	Full Roll
	24.00	18.00

**Buy or Rent**

**FRAZZLE**

**Flame Retardant.** Silver or Gold metallic sheen etched by half circle cuts which track across the entire surface. A peek-a-boo appearance that can be used in either direction for different 3D effects. A knock-out fabric!

Roll = Approx. 75 yds.

59" <b>FR</b>	Price Per Yard	
	Cut	Full Roll
	19.50	13.00

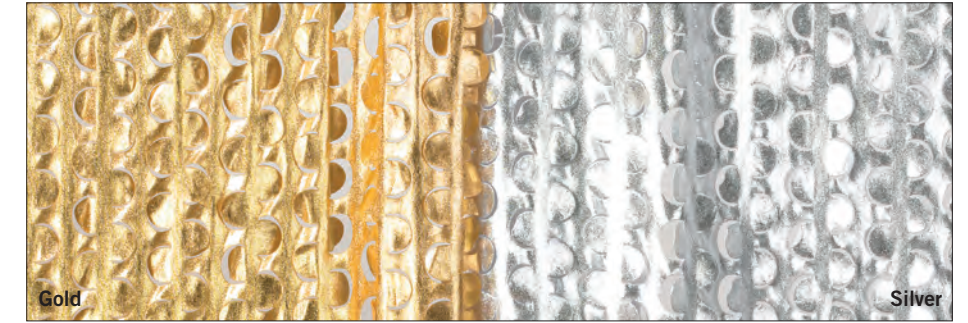

**SHIMMERLITE**

**Inherently Flame Retardant.** Trevira®/Lurex. Lightweight white fabric interwoven with Gold and Silver metallic thread. Drapes and lights beautifully.

Roll = Approx. 55 yds.

10'9" <b>IFR</b>	Price Per Yard	
	Cut	Full Roll
	45.00	34.50

**LIQUID METAL**

**Flame Retardant.** No heavy metal here. These lightweight metallic fabrics flow like quicksilver. This glitzy, soft fabric delivers the creative wow factor with excellent draping and is highly light reflective for added punch. There is no limit to the ways you could use this lux decorative material.

Roll = Approx. 50 yds.

56" <b>FR</b>	Price Per Yard	
	Cut	Full Roll
	10.50	8.50

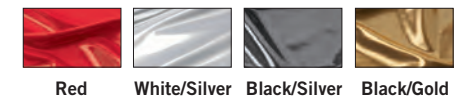
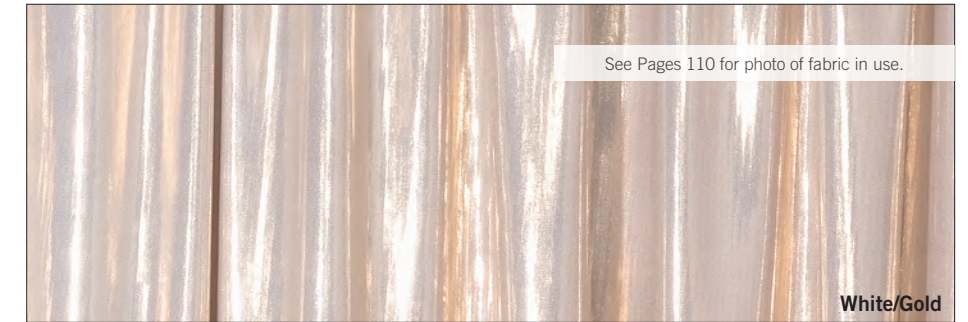

**ROSCO SHIMMER SCRIM**

**Inherently Flame Retardant.** A unique woven combination of fabric and metallic. May be used for "bleed-through effects" or as a shimmering, airy drape.

For additional colors go to RoseBrand.com.

Roll = Approx. 10 yds.

47" <b>IFR</b>	Price Per Roll
	176.35

**METALLIC KNIT BOUCLÉ**

**Flame Retardant.** Highly reflective, textured, knit metallic that drapes beautifully. Slight stretch.

Roll = Approx. 100-110 yds.

58" <b>FR</b>	Price Per Yard	
	Cut	Full Roll
	12.00	8.50





Metallic



Opalescent

**GLACIER**

**Inherently Flame Retardant.** Brilliant iridescent opalescent sheer fabric. Looks like it's made out of pearl.

Roll = Approx. 55 yds.

	Price Per Yard	
	Cut	Full Roll
109" <b>FR</b>	24.00	16.00

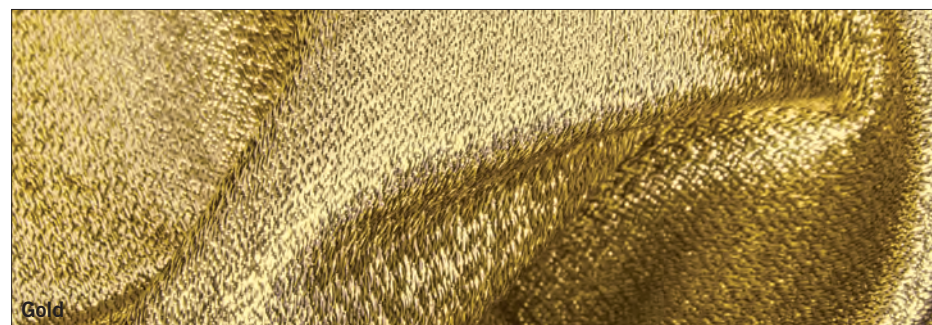

Gold

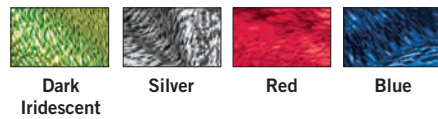

**SHOWSTOPPER**

**Flame Retardant.** 100% Polyester. Lustrous metallic fabric that's perfect for the glitziest events and settings.

Roll = Approx. 66 yds.

	Price Per Yard	
	Cut	Full Roll
118" <b>FR</b>	21.00	14.00

Metallic



Buy or Rent

**DUET**

**Inherently Flame Retardant.** The swanky duo of glistening and matte surfaces create the upscale look and feel of this fabric. Wrinkle resistant.

Roll = Approx. 50-60 yds.

	Price Per Yard	
	Cut	Full Roll
54" <b>IFR</b>	14.09	10.85

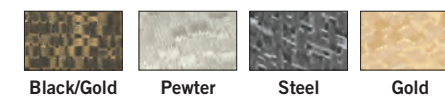

- Fabrics
- Black Masking
- Custom Stage Curtains & Backdrops
- Custom Special Event Sewing
- Digital Printing
- LED Star Drops
- Pipe & Base
- Rentals
- Projection Materials
- Flooring
- Curtain Track
- Stage Equipment, FXs & Mirrors
- DMX Winches
- Scenery Props
- Shop & Production Supplies
- Tape
- Film & Video Supplies
- Index





Product: Muslin, Scrim; Ray LaMontagne, *Just Passing Through* Tour; Lighting and Production Design: Jeremy Roth; Scenic Design: Valerie Light; Scenic Fabrication: Infinite Scenic, Cobalt Studios, Rose Brand; Lighting Supplier: TMS Omaha

## Linen & Gauze

### LUSTRE NET

**Inherently Flame Retardant.** 100% Polyester. Striking, sparkling decorative netting ideal for lighting and projection.

Roll = Approx. 50-70 yds.

	Price Per Yard	
	Cut	Full Roll
112" <b>IFR</b>	20.25	13.50

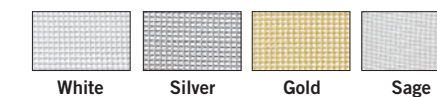
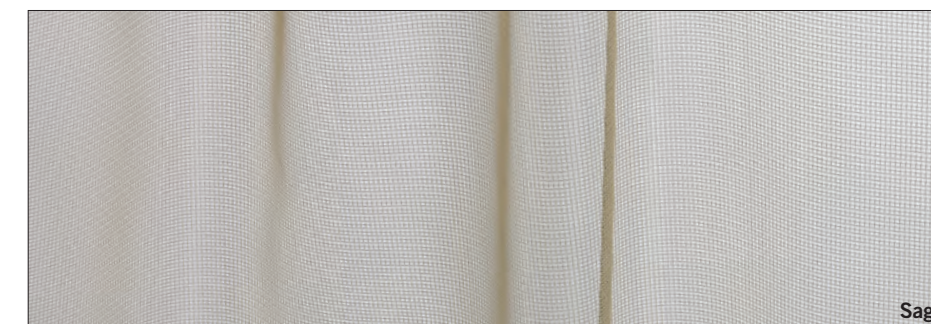

### FINE GAUZE

100% Cotton. Fine Gauze is a lightweight cotton available in wide, seamless widths with a beautiful, consistent and stable weave.

Full Piece = Approx. 65 yds.

	Price Per Yard		
		Cut	Full Piece
Natural 9'9" NFR	9.75	6.50	
Natural 9'9" <b>FR</b>	12.75	8.50	
White 9'9" <b>FR</b>	16.50	11.00	
Black 9'9" <b>FR</b>	17.25	11.50	
Natural 19'6" NFR	26.25	21.00	
Natural 19'6" <b>FR</b>	44.00	36.00	
White 19'6" <b>FR</b>	56.00	40.00	
Black 19'6" <b>FR</b>	62.40	48.00	
Natural 32'9" NFR	78.00	60.00	

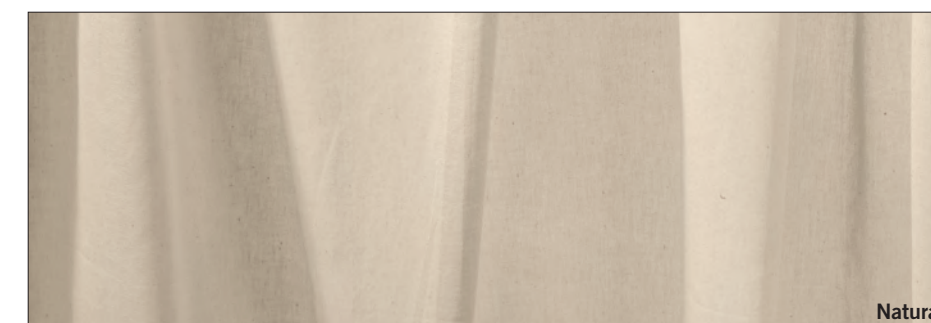

### RUSTICA

**Inherently Flame Retardant.** 120" wide, synthetic gauze has an organic look and texture but with the versatility and durability of an **IFR** polyester. Great for digital printing. Drapes beautifully.

Roll = Approx. 50-60 yds.

	Price Per Yard	
	Cut	Full Roll
120" <b>IFR</b>	21.00	14.00





## Linen & Gauze



Natural



Off-White

### THEATRICAL GAUZE

100% Linen. Theatrical Gauze is a durable but light gauze with a rustic texture that, when properly lit, allows a bleed-through effect similar to that of Sharktooth Scrim.

Roll = Approx. 55 yds.

		Price Per Yard	
		Cut	Full Piece
Natural	72" NFR	18.75	12.50
Off-White	72" NFR	20.62	13.75
Natural	66/67" <b>FR</b>	21.00	14.00
Off-White	66/67" <b>FR</b>	22.25	15.00

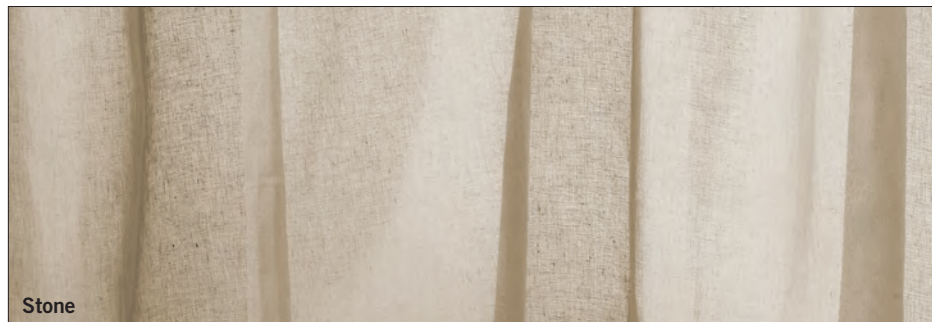

Stone



White



Natural

### COTTON SCRIM

100% Cotton. Ultra-fine gauze that drapes beautifully. Used in special events and interior decorating as well as in theatres for quick and economical swags and billows that are light as a feather.

Roll = Approx. 100 yds.

		Price Per Yard	
		Cut	Full Roll
55"	NFR Natural/White	3.24	1.75
54"	<b>FR</b> Natural/White	6.46	4.15
60"	<b>FR</b> Stone	6.53	4.50

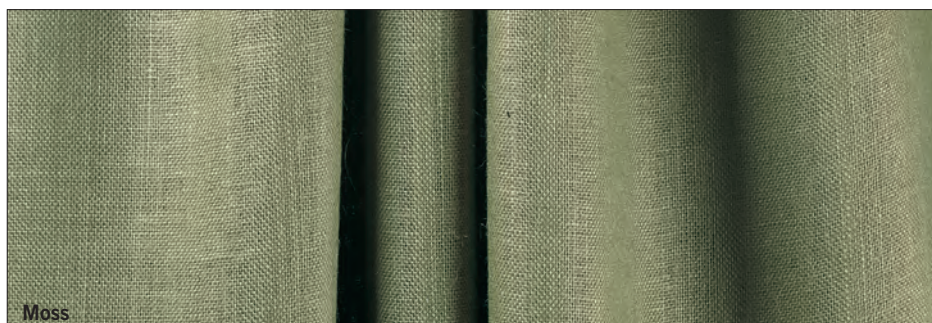

Moss

### BURLAP COLORS

Can be made **Flame Retardant**. 10 oz. tight weave burlap in colors that really pop. (Allow 1 week for **FR** treatment.)

Roll = Approx. 50 yds.

**FR** Minimum 50 yds.

		Price Per Yard	
		Cut	Full Roll
59"	NFR	11.25	7.50
59"	<b>FR</b>	17.25	11.50



Product: Muslin, Rosco Flexbond™, Jaxsan 600 White Acrylic Latex Coating; Ogunquit Playhouse, *From Here to Eternity*; Designer: Adam Koch; Technical Director: Geof Dolan; Scenic Charge: Cheryl Dolan; Photo: Gary Ng



**KAOS**  
RANDOM PATTERN  
**TEXTURAL**  
SCENIC  
PRODUCT

**KAOS**

**Flame Retardant.** This handmade material features a textured, random, and chaotic quality. Available in fine, medium, heavy, or open thread. Kaos is and can be used in a multitude of ways including set designs, trade shows, special events, interior design, projection, and costumes. Grey Kaos is great for lighting and projection effects. **\*Must ship on a roll. Scale: 2" = 1'.**

Kaos, Fine		Price Per Yard	
Full Piece = Approx. 55 yds.	Cut	Full Piece	
Black 118"	<b>FR</b>	75.00	63.00
Natural 118"	<b>FR</b>	75.00	63.00

Kaos, Medium		Price Per Yard	
Full Piece = Approx. 27 yds.	Cut	Full Piece	
Black 118"	<b>FR</b>	85.00	71.40
Natural 118"	<b>FR</b>	85.00	71.40

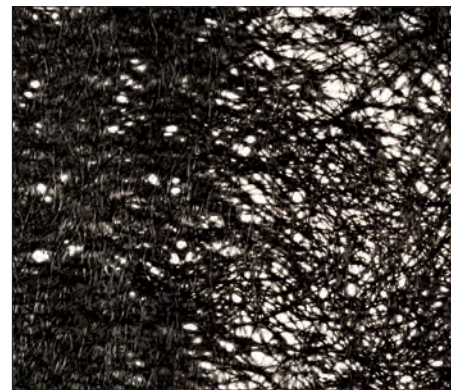

Fine Black

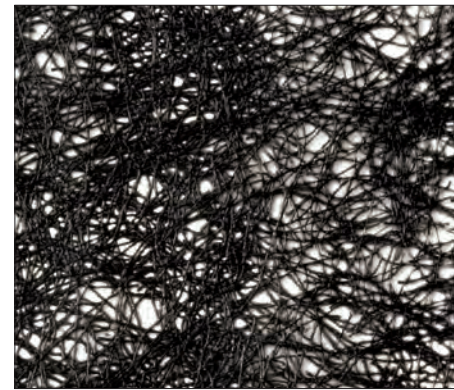

Medium Black

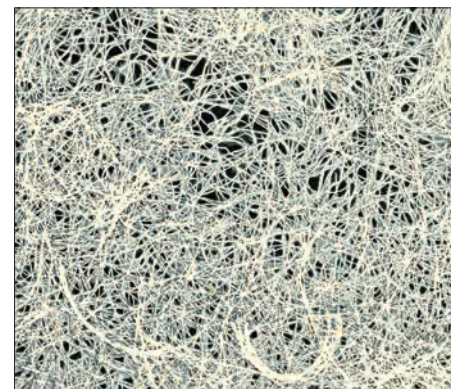

Fine Natural

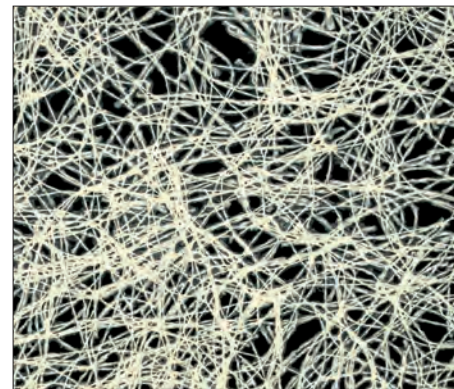

Medium Natural

Kaos, Heavy		Price Per Yard	
Full Piece = Approx. 22 yds.	Cut	Full Piece	
Black 118"	<b>FR</b>	81.00	68.25
Natural 118"	<b>FR</b>	81.00	68.25
Grey 118"	<b>FR</b>	81.00	68.25

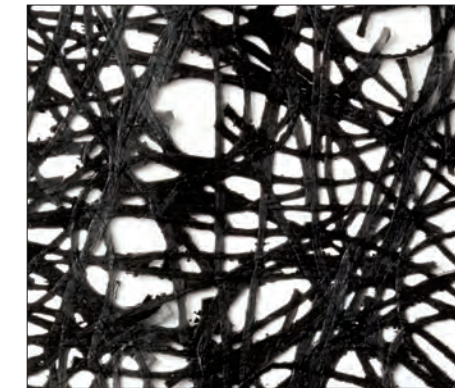

Heavy Black

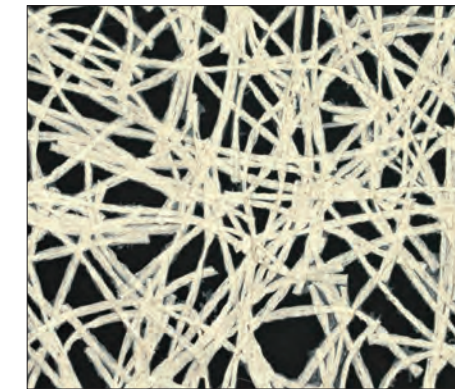

Heavy Natural

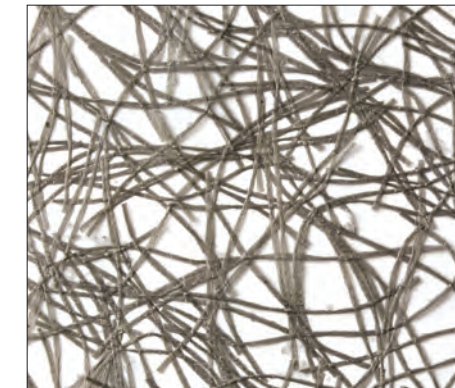

Heavy Grey

Kaos, Open		Price Per Yard	
Full Piece = Approx. 27 yds.	Cut	Full Piece	
Black 118"	<b>FR</b>	81.00	68.25
Natural 118"	<b>FR</b>	81.00	68.25
Grey 118"	<b>FR</b>	81.00	68.25

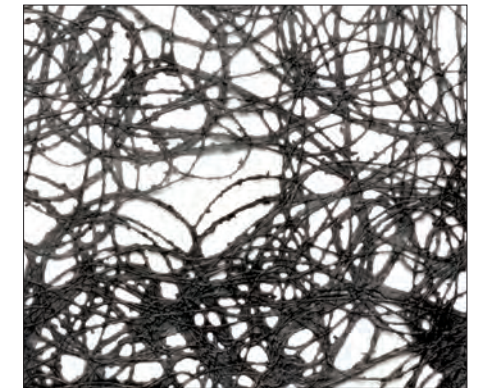

Open Black

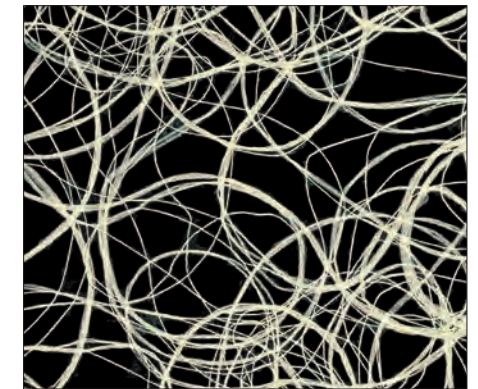

Open Natural

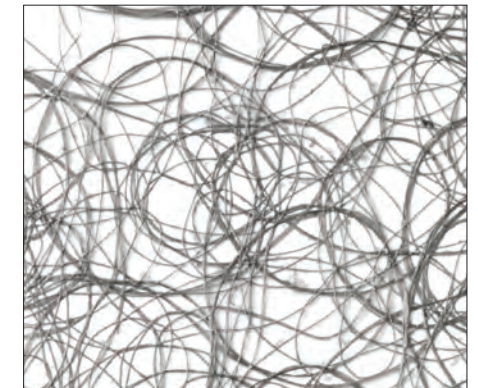

Open Grey



Product: Voile and Kaos; *Glass Menagerie* at Northwestern University Theatre; Designer: Janie E. Howland; Technical Director: Eric Kelley; Lighting Designer: Oliver Wason; Photo: Janie E. Howland  
All Rose Brand Flame Retardant Fabrics meet NFPA 701 testing. See RoseBrand.com for additional FR standards and registration numbers.



## Textured & Matte

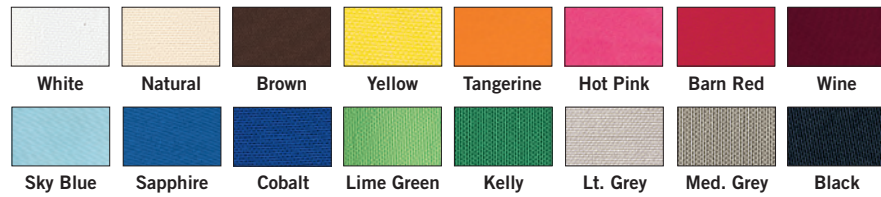

### POLY MUSLIN

**Inherently Flame Retardant.** This medium weight Avora™ polyester has the look and weight of cotton muslin without the stiffness. Especially good for drops and cycs in high humidity conditions.

Roll = Approx. 100-110 yds.

	Price Per Yard		
	Cut	Full Roll	500+ Yds*
128" <b>IFR</b>	16.50	11.00	9.50

#### VOLUME DISCOUNT

\*Must be Purchased in Full Roll/Piece Increments.



### POLY KNIT

**Inherently Flame Retardant.** Durable knitted polyester. Slight stretch makes it easier to attach to frames. Custom colors available - 250 yd. minimum.

Roll = Approx. 50-60 yds.

	Price Per Yard	
	Cut	Full Roll
66" <b>IFR</b>	9.90	6.60



### BUDGET LINER (TENT LINER)

**Inherently Flame Retardant.** 100% Polyester. The most economical, wide width, **IFR** tent lining fabric available today. Available in Black and White.

Roll = Approx. 125 yds.

	Price Per Yard	
	Cut	Full Roll
128" <b>IFR</b> White, Black	9.90	6.60

### ECO LINER

**Flame Retardant.** This tent liner fabric is made from 100% recycled content and is itself 100% recyclable. It's manufactured from Repreve™, a yarn comprised of polyester and plastic. Available in Black.

Roll = Approx. 100 yds.

	Price Per Yard	
	Cut	Full Roll
60" <b>FR</b> Black	7.42	4.95

## Textured & Matte

### BANJO CLOTH

**Inherently Flame Retardant.** Raised shiny texture on matte background. Used extensively for trade show drapery. Medium weight.

Roll = Approx. 100-150 yds.

	Price Per Yard		
	Cut	Full Roll	500+ Yds*
48" <b>IFR</b>	6.50	4.25	3.95

#### VOLUME DISCOUNT

\*Must be Purchased in Full Roll/Piece Increments.

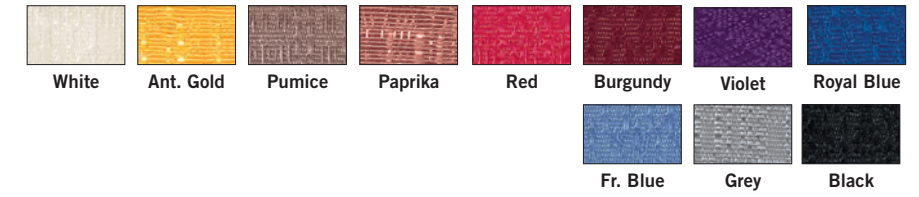
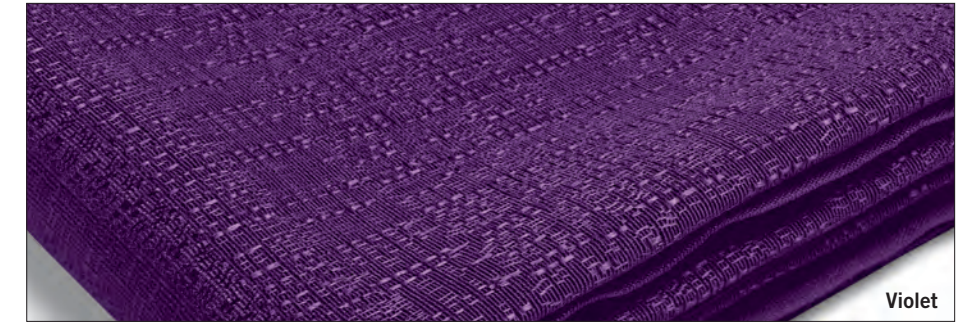

### POLY CHINTZ

**Inherently Flame Retardant.** Sateen finish, ideal for draperies.

Roll = Approx. 90-100 yds.

	Price Per Yard	
	Cut	Full Roll
58" <b>IFR</b>	6.15	4.75



### POLY PREMIER

**Inherently Flame Retardant.** Reversible, it's great for trade show pipe and drape as an alternative to Banjo Cloth, skirting and tablecloths.

Roll = Approx. 90-100 yds.

	Price Per Yard		
	Cut	Full Roll	500+ Yds*
61" <b>IFR</b>	6.40	4.25	3.75

#### VOLUME DISCOUNT

\*Must be Purchased in Full Roll/Piece Increments.

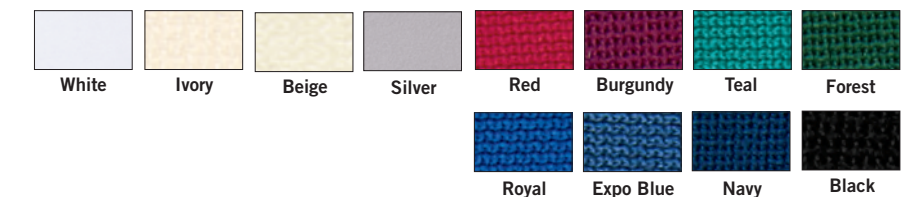



## Textured & Matte

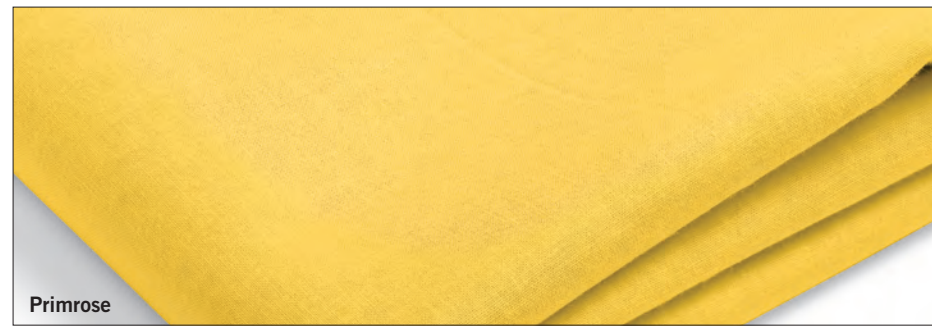

### CELEBRATION CLOTH

**Flame Retardant.** 100% Cotton. No celebration is complete without color. Decorate your next event with this lightweight, affordable cotton.  
Roll = Approx. 110-124 yds.

48" FR	Price Per Yard	
	Cut	Full Roll
	6.66	4.44



### RB CLOTH

**Inherently Flame Retardant.** AKA "PD Cloth." Never worry about flame proofing again. Great for arenas, amusement parks, ice shows, and multi-purpose facilities.  
Roll = Approx. 90 yds.

72" IFR	Price Per Yard		
	Cut	Full Roll	500+ Yds*
	12.75	8.50	7.00

**VOLUME DISCOUNT**  
\*Must be Purchased in Full Roll/Piece Increments.

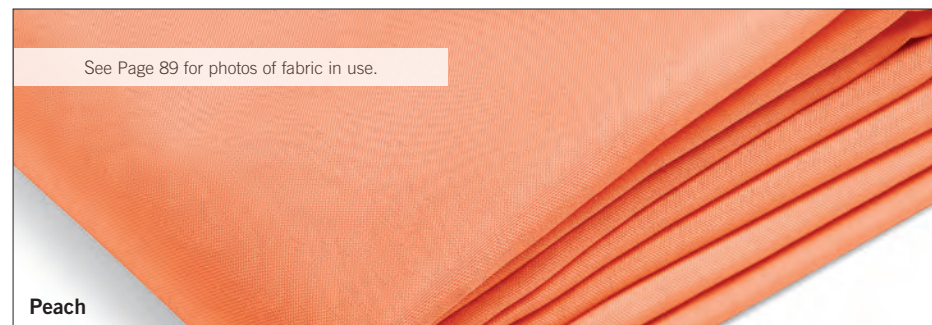

### POLY CYC

**Inherently Flame Retardant.** Drapes and lights beautifully. A synthetic Muslin without the wrinkles.  
Roll = Approx. 105-130 yds.

128" IFR	Price Per Yard	
	Cut	Full Roll
	16.50	11.00

## Textured & Matte

### PARTY KNIT

**Inherently Flame Retardant.** 100% Polyester. Make the transformation to "Event" quick, easy, and inexpensive with 25 colors to choose from.  
Roll = Approx. 150-170 yds.

58" IFR	Price Per Yard		
	Cut	Full Roll	500+ Yds*
	6.00	4.00	3.25

**VOLUME DISCOUNT**  
\*Must be Purchased in Full Roll/Piece Increments.

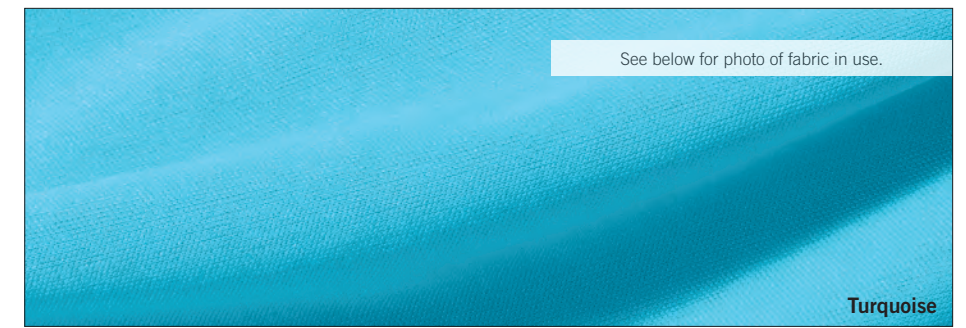

Product: Party Knit; Arturo Fuente Cigar Factory, Tampa FL; Planner: Stonehouse Events; Designer: Tommy Murphy, Swag Decor



**TEXTILENE®**

**Inherently Flame Retardant/Non Flame Retardant.** PVC Coated Polyester. Sturdy weatherproof mesh for covering speaker towers and backdrops with lighting and laser projection. Low acoustic absorption. The 36% open mesh (54") and 28% open mesh (98") decreases wind resistance. See page 80 for photo of fabric in use. Roll = Approx. 50-60 yds.

**Price Per Yard**

	Cut	Full Piece
54" NFR Colors	13.42	8.95
98" IFR Black, White, Silver*	24.00	16.00

\*Silver Available in 98" only.

**MELT OUT**

**Inherently Flame Retardant.** New more economical overhead trade show ceiling fabric for stretched ceilings over exhibitions, trade show booths, and museum displays. Melt Out diffuses light beautifully and in the event of a fire, meltable seams every 12" along the length of the fabric open allowing smoke to escape and water from sprinklers to come through. Roll = Approx. 50 yds.

**Price Per Yard**

	Cut	Full Roll	500+ Yds*
96" IFR White	32.10	26.75	21.00
96" IFR Black/Colors	34.80	29.00	22.85

**VOLUME DISCOUNT**

\*Must be Purchased in Full Roll/Piece Increments.



Silver



White Yellow Red Dk. Blue

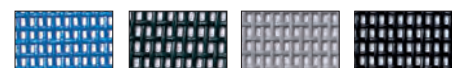

Royal Blue Forest Dove Grey Black

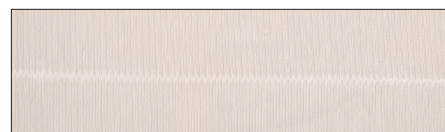

Light Grey

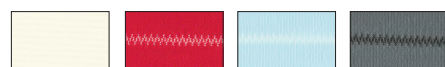

White Red Blue Dark Grey



Black

**SMOKE OUT®**

**Inherently Flame Retardant.** Trevira CS®. For ceilings. Diffuses light beautifully and in the event of a fire, meltable seams every 12" allow smoke to escape and sprinklers to come through. Roll = Approx. 55 yds.

**Price Per Yard**

	Cut	Full Roll
110" IFR Grey	65.21	48.30

*The standard for trade show booth ceilings in Europe!*

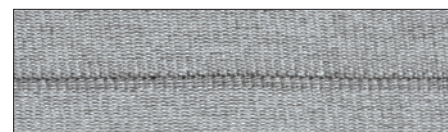

Grey

**FIRESIST™ (AKA SUNBRELLA)**

**Inherently Flame Retardant.** Woven from an IFR polymer and backed with a durable urethane/acrylic coating, it has excellent flexibility making it easy to sew. Perfect for outdoor use - it's mildew and fade resistant. 9.5 oz/sq. yd. Roll = Approx. 60 yds.

**Price Per Yard**

	Cut	Full Roll
60" IFR	38.70	32.25

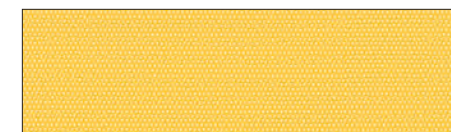

Sunburst



Ivory Sand Crimson Regatta



Admiral Forest Black

**RIP STOP NYLON**

**Flame Retardant.** Designed to prevent rips or tears from spreading. Commonly used for banners, flags, exhibitions and displays. Roll = Approx. 100 yds.

**Price Per Yard**

	Cut	Full Roll	500+ Yds*
60" IFR	12.00	8.00	6.80

\*Cut yardage available only in stocked colors indicated.

**VOLUME DISCOUNT**

\*Must be Purchased in Full Roll/Piece Increments.



Orange



White\* Yellow\* Red\* Royal\*



Navy Silver Black\*

**WEBLON**

**Inherently Flame Retardant.** Extra strong vinyl fabric for outdoor applications. Manageable weight for superior resistance to sag and stretch. Age, fade, dirt, and mildew resistant. Roll = Approx. 50 yds.

**Price Per Yard**

	Cut	Full Roll
62" IFR	24.40	18.75

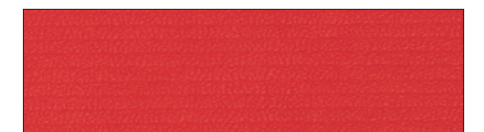

Deep Red



White Ivory Bay Blue Deep Sea



Harbor Gr. Black



## Expo & Outdoor

### FR BLACK CORDURA

**Flame Retardant.** This versatile 100% nylon utility fabric is super strong, durable, water repellent, and quick drying, with excellent resistance to fading, abrasion, puncture, tear, scuffs, rot, and mildew. Heavy duty 1000 Denier Black Cordura will make strong, long-lasting products even tougher. Reverse side is grey.

Roll = Approx. 50 yds.

	Price Per Yard	
	Cut	Full Roll
60" <b>FR</b>	24.00	18.00

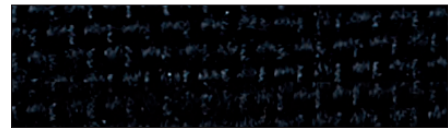

Black

### BLACK/WHITE SAIL CLOTH

**Flame Retardant.** This 100% nylon, opaque fabric has ideal masking properties. It has both a white and a black side, each with a subtle grid pattern. For both outdoor and indoor use. Water repellent.

Roll = Approx. 100 yds.

	Price Per Yard	
	Cut	Full Roll
60" <b>IFR</b>	11.85	9.85



White

Black

### DISPLAY FELT

**Flame Retardant.** 72% Viscose/28% Wool. 9 oz. per linear yard. Matte, brushed texture, non-woven.

Roll = Approx. 33-65 yds.

	Price Per Yard	
	Cut	Full Roll
72" <b>FR</b>	18.00	12.00

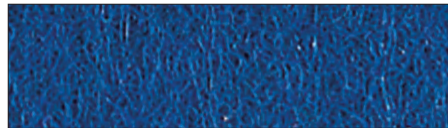

Royal



### CORDURA

Non Flame Retardant. Nylon, 1000 denier. Durable, weather resistant fabric made for outdoor applications.

Roll = Approx. 50 yds.

	Price Per Yard	
	Cut	Full Roll
59" NFR	17.55	13.50



Navy

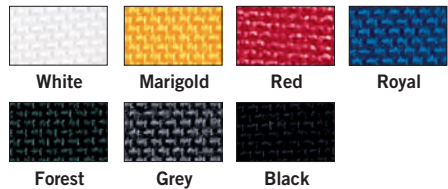

### FLAG BUNTING FANS

**Inherently Flame Retardant.** Show your colors with patriotic bunting. Great for holiday decorations, commencements, civic events and the "big game". Made of **Inherently Flame Retardant** heavy weight synthetic RB Cloth, these sturdy fans can be used indoors or out. Webbing and Grommets on top.

Size	Price
2'H x 4'W <b>IFR</b>	38.00
3'6"H x 7'W <b>IFR</b>	55.00



Make sure your flag bunting is Flame Retardant!  
100% Made in the USA!



Product: Sharktooth Scrim; Grace Point Church, Bentonville AR; Designer: Tim Logan; Photo: Tim Logan

All Rose Brand Flame Resistant Fabrics Pass NFPA 701 testing. See RoseBrand.com for additional FR standards and registration numbers.



# Acoustically Tested Fabrics & Foam

Fabrics play an important role in controlling the acoustics of many architectural environments: theaters, concert halls, auditoriums, event spaces, meeting rooms, churches, recording studios, museums, restaurants, and more.

Performance venues in particular have acoustical needs that require adjustment depending on what is presented. Curtains and fabric panels are easily adjusted, relatively economical, and often an integral design element.

Below are acoustical test results for 13 of our fabrics that are widely used for sound absorption. The results here are for a 100% fullness pleated panel.

The full reports from the testing lab are available on each product page at [RoseBrand.com](http://RoseBrand.com).

Acoustical Fabric Charts for a 100% fullness pleated panel.

## 12 OZ. BRAVA IFR

See Page 41 for Fabric Colors.

Noise Reduction Coefficient (NRC): 0.85  
Sound Absorption Average (SAA): 0.86

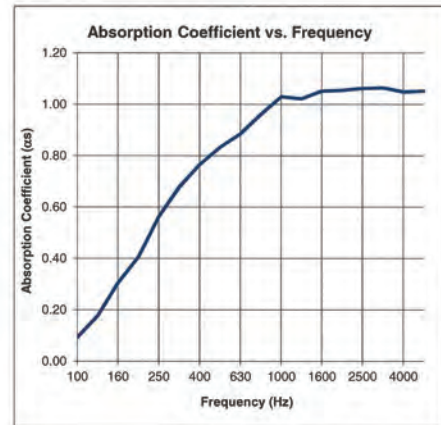

## 13 OZ. APOLLO IFR

See Page 40 for Fabric Colors.

Noise Reduction Coefficient (NRC): 0.95  
Sound Absorption Average (SAA): 0.92

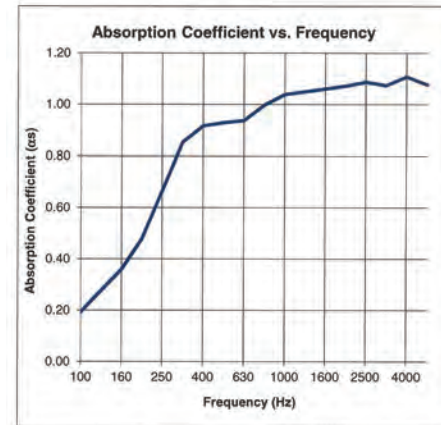

## 20 OZ. CRESCENT IFR

See Page 30 for Fabric Colors.

Noise Reduction Coefficient (NRC): 0.95  
Sound Absorption Average (SAA): 0.96

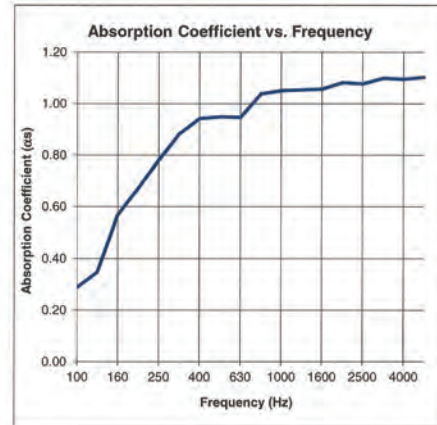

## 22 OZ. ENCORE IFR

See Page 33 for Fabric Colors.

Noise Reduction Coefficient (NRC): 1.00  
Sound Absorption Average (SAA): 0.99

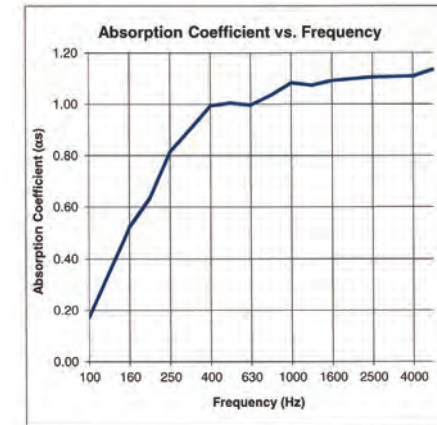

## 25 OZ. MEMORABLE FR

See Page 42. Stocked in Black only. Other colors available by special order.

Noise Reduction Coefficient (NRC): 1.05  
Sound Absorption Average (SAA): 1.04

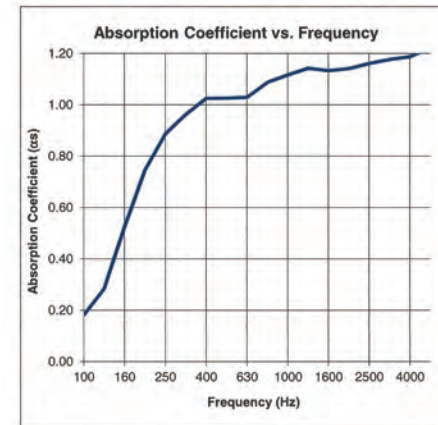

## 32 OZ. MAGIC FR

See Page 42. Stocked in Black only. Other colors available by special order.

Noise Reduction Coefficient (NRC): 0.95  
Sound Absorption Average (SAA): 0.92

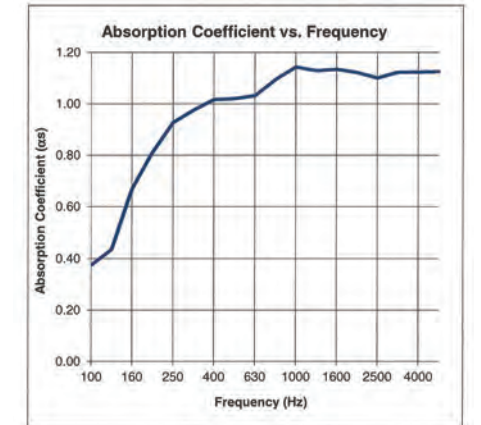

## 30 OZ. WOOL SERGE IFR

See Page 46. Stocked in Black only. Other colors available by special order.

Noise Reduction Coefficient (NRC): 1.00  
Sound Absorption Average (SAA): 1.01

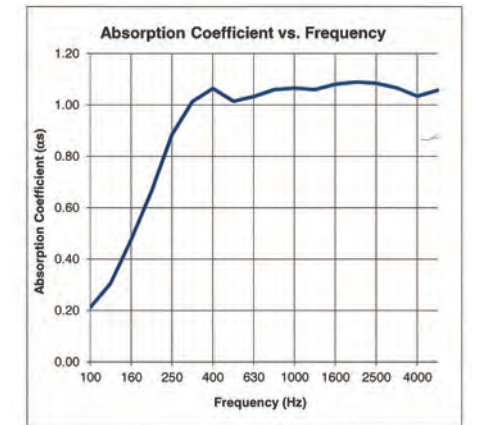

## 15 OZ. ENCORE IFR

See Page 33 for Fabric Colors.

Noise Reduction Coefficient (NRC): 0.90  
Sound Absorption Average (SAA): 0.88

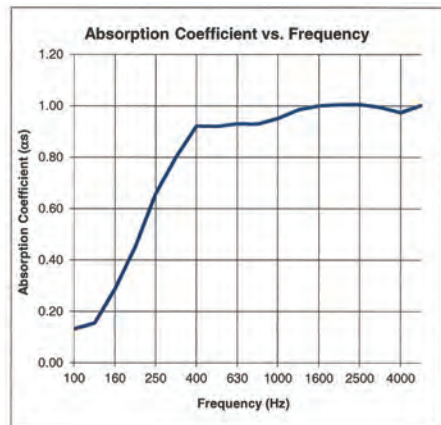

## 16 OZ. ATHENA IFR

See Page 37 for Fabric Colors.

Noise Reduction Coefficient (NRC): 0.95  
Sound Absorption Average (SAA): 0.93

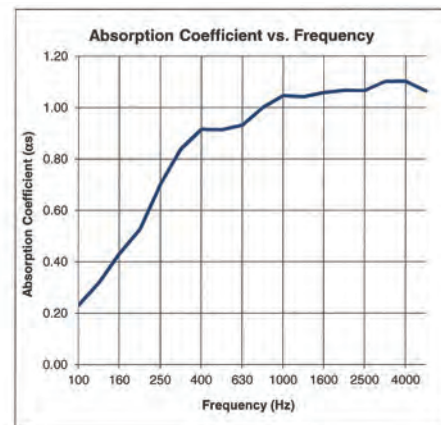

## 25 OZ. CHARISMA IFR

See Page 30. Custom Colors Only.

Noise Reduction Coefficient (NRC): 0.90  
Sound Absorption Average (SAA): 0.90

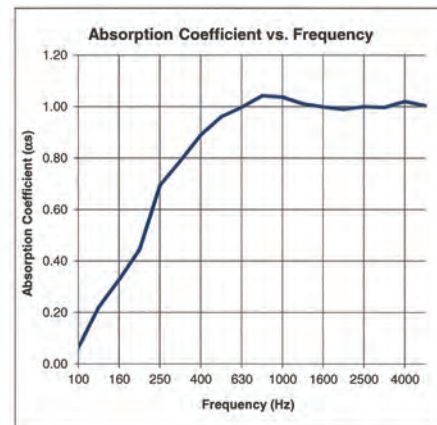

## 25 OZ. PRESTIGE IFR

See Page 30. Custom Colors Only.

Noise Reduction Coefficient (NRC): 0.90  
Sound Absorption Average (SAA): 0.92

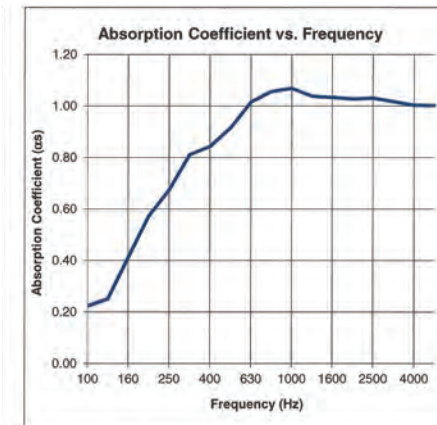

## 32 OZ. IMPERIAL IFR

See Page 29. Custom Colors Only.

Noise Reduction Coefficient (NRC): 1.00  
Sound Absorption Average (SAA): 1.00

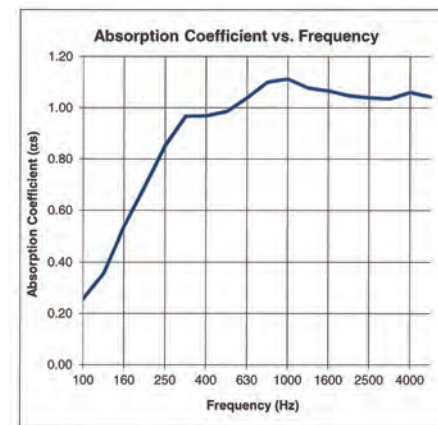

## 32 OZ. ROYALE IFR

See Page 29. Custom Colors Only.

Noise Reduction Coefficient (NRC): 0.95  
Sound Absorption Average (SAA): 0.95

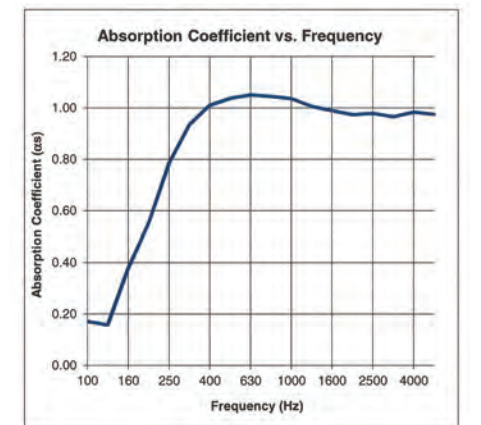





Product: Encore, Charisma Fabric and lining sewn with 100% fullness; Brook Arts Center; Photo: Louis Peter



**SONOSTOP®**

**Inherently Flame Retardant.** Non-woven sound absorbing acoustical backing for use with sound absorbing or acoustically transparent face fabrics. See Rosebrand.com for ASTM C-423 test results.

Piece = 58 yds

		Cut	Full
60"	IFR	18.00	15.00

**RHAPSODY IFR**

Rhapsody Acoustic Fabric for digital printing provides superb color saturation, high resolution and an impressive NRC of 1.00 that lets you turn acoustic wall panels into custom works of art. This 120" **IFR** polyester fabric gives you the freedom to design large seamless prints to cover acoustical panels without interfering with the panel's absorption. Rhapsody is the perfect solution for museums, performance venues, offices and houses of worship. **Call for pricing.**

Noise Reduction Coefficient (NRC): **1.00**  
 Sound Absorption Average (SAA): **0.98**

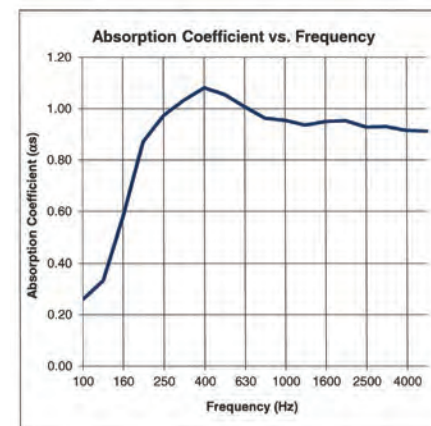

Tested stretched flat on acoustical panel.

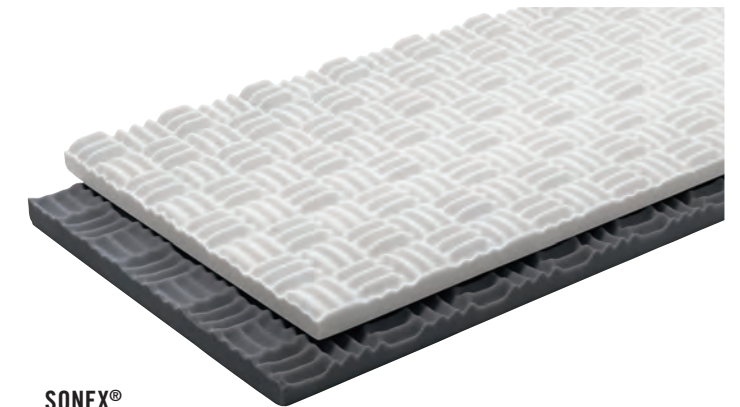

**SONEX®**

SONEX® One Panels are versatile and effective for acoustic control in a variety of applications in a wide range of settings, including multi-purpose rooms, themed attractions, retail stores, restaurants, orchestra pits, and green rooms. Great for off-stage sound deadening.

Attractive and reliable, Sonex® One Panels feature Noise Reduction Coefficient (NRC) ranging from 0.85 to 1.10 depending on context.

The sculpted surface of each panel deflects and disperses sound waves, allowing the open-cell willtec® foam to convert sound energy into quiet, kinetic energy.

Panels have a Class 1 Fire Rating and are 24" x 48", 2" thick. Panels are priced individually, but must be purchased in pairs of the same color. White has beveled edges, Charcoal does not.

	Price Per Panel
Natural White	70.00
Charcoal	65.00

Panels sold by the PAIR. Must be same color.

	Sonex® Accessories
AcouStic® Adhesive 10.5 oz Tube (Coverage is 32 sq ft per tube)	6.70
AcouStic® Adhesive 5 gallon pails (Coverage is 260 square feet)	235.00
Standard Caulking Gun for application	8.20

\* The AcouStic Adhesive is water based.

**SONEX ONE PANELS**

Noise Reduction Coefficient (NRC): **0.85**

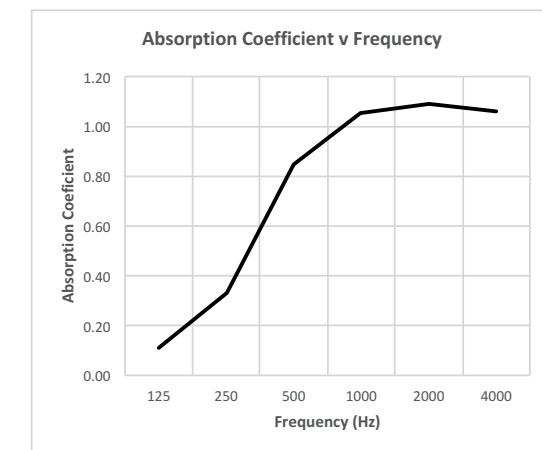





**ROSE BRAND SAMPLE BINDER**

Our Signature Rose Brand Binder contains our current color cards with swatches of many of our most popular fabrics. <http://bit.ly/sample-cards>

\$95.00

**SWATCH CARDS**

\$2.00 Each

**PRODUCTION FABRICS SWATCH BOOK**

\$50.00 Each



All Rose Brand flame retardant fabrics are, at a minimum, certified to meet the requirements of the National Fire Protection Association's (NFPA) 701 standard, which is the standard designated by 49 out of 50 states in the U.S. Whenever possible, testing to the California flame resistance standard is determined as well and included in our certificate of flame retardancy. When compliance with other standards is known, this information is also automatically added to our certificates of flame retardancy.

**Inherently Flame Retardant**

An **IFR** fabric has flame resistance achieved naturally or with a chemical introduced to be an integral part of the fabric's fiber, such that the fabric meets the requirements of a government's flame retardancy standard. This flame resistance cannot be washed out and will never leach out. The treatment results in an inherent flame resistance for the life of the fabric. These fabrics can be water washed or dry cleaned.

**Flame Retardant**

An **FR** fabric has always been treated with a chemical to increase its resistance to ignition, making it acceptable to a flame retardancy standard. The chemical, however, is water soluble so these fabrics cannot be water washed or allowed to get damp. Sometimes, these fabrics can be dry cleaned. Check with your Rose Brand sales representative or customer service person.

**Non Flame Retardant**

An **NFR** fabric cannot be treated with a chemical so that it meets any of the standards for flame resistance. These fabrics are seldom used on stages or, if they are, they are used in limited quantities and with special precautions prearranged with the local fire marshal.

**Can be made Flame Retardant**

This designation is provided when a fabric is used both as an NFR and an **FR** product. Usually, the **FR** treatment is applied only upon request.

**Precautions**

Any fabric is certified as **FR** or **IFR** only if its composition has not been changed by the addition of any substance such as adhesives, sizing, paint, dyes, inks or anti-staining coatings. Any such addition voids the flame retardancy certification of the fabric. Each of these additions needs its own certification of flame resistance as well as the final composition needs separately to be certified.

Accumulations of dust and other air-borne particles, as well as frequent handling with bare hands, contribute to the degradation of the flame retardant character of any fabric. For this reason, flame retardant fabrics should be checked periodically. For guidance on testing and about the proper handling of fabrics or draperies, visit [RoseBrand.com](http://RoseBrand.com) or give us a call.

Call for samples prior to ordering to assure accurate color choice. All swatches represented are photographic reproductions. Colors in this catalog may differ from the actual color of dyed textiles.

With each shipment of our Flame Retardant fabrics or drapes, Rose Brand includes a copy of the appropriate FR certificate with the shipping documents. Requests for additional or replacement copies of FR certificates may be directed to [FRcertificates@rosebrand.com](mailto:FRcertificates@rosebrand.com). With each shipment Rose Brand will send the buyer an email version of the FR certificate automatically.



# Custom Stage Curtains & Backdrops

- Custom Fabric Constructions .....142
- Specifying Soft Goods.....144
- Typical Stage Layout ..... 145
- Stage Curtain Types.....146**
- Stage Curtains ..... 147
- Curtain Fullness..... 148
- Curtain Fullness Types..... 149
- Top Finishes.....150
- Side Finishes ..... 151
- Bottom Finishes.....152
- Swags & Jabots ..... 153
- Linings..... 153
- Tassels, Trim & Fringe .....154**
- Fire Curtains .....158**
- Fire Curtains FR Testing, Cleaning & Repairs ..... 158

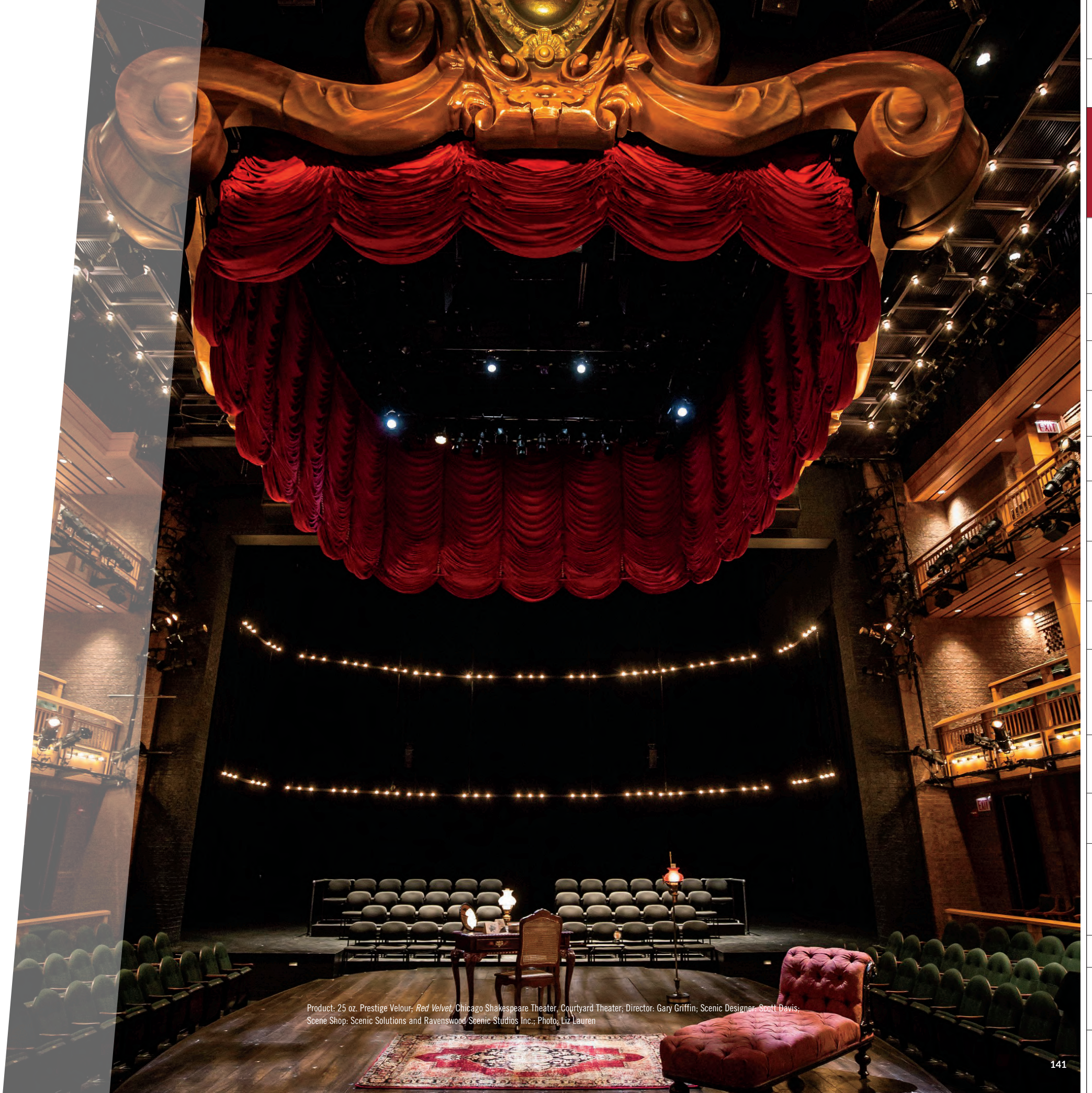

Product: 25 oz. Prestige Velour, *Red Velvet*, Chicago Shakespeare Theater, Courtyard Theater; Director: Gary Griffin; Scenic Designer: Scott Davis; Scene Shop: Scenic Solutions and Ravenswood Scenic Studios Inc.; Photo: Liz Lauren

- Fabrics
- Black Masking
- Custom Stage Curtains & Backdrops**
- Custom Special Event Sewing
- Digital Printing
- LED Star Drops
- Pipe & Base
- Rentals
- Projection Materials
- Flooring
- Curtain Track
- Stage Equipment, FXs & Mirrors
- DMX Winches
- Scenery Props
- Shop & Production Supplies
- Tape
- Film & Video Supplies
- Index



# Custom Fabric Constructions

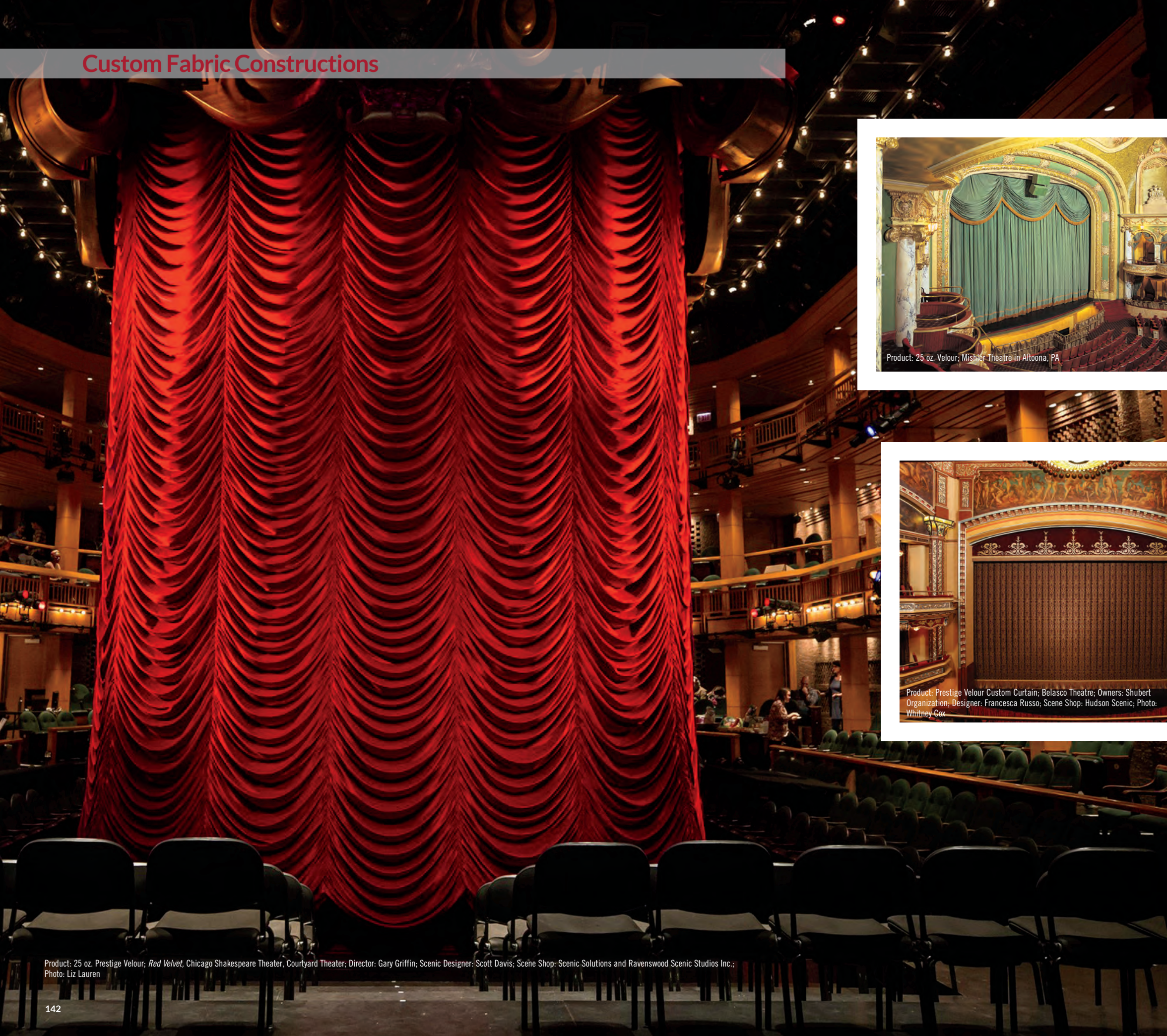

Product: 25 oz. Prestige Velour; *Red Velvet*, Chicago Shakespeare Theater, Courtyard Theater, Director: Gary Griffin; Scenic Designer: Scott Davis, Scene Shop: Scenic Solutions and Ravenswood Scenic Studios Inc.; Photo: Liz Lauren

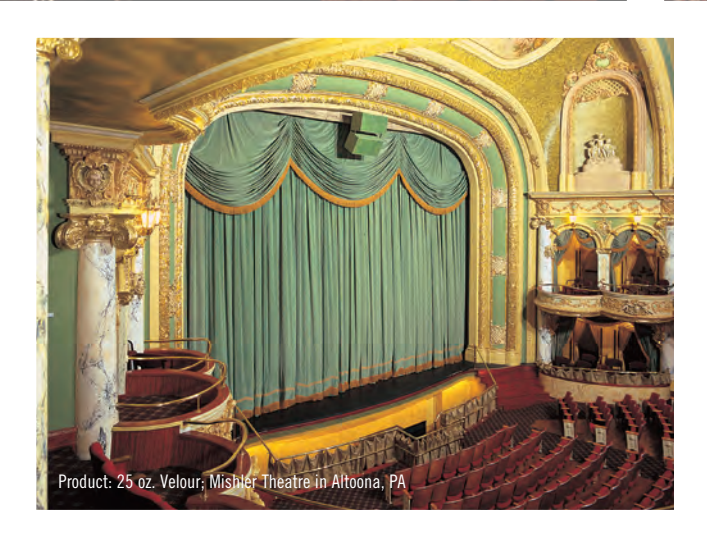

Product: 25 oz. Velour, Mishler Theatre in Altoona, PA



Product: Main Curtain and Valance; Fabric: 25 oz. Prestige Custom Color; Project Management: Rose Brand; BAM Howard Gilman Opera House; Photo: T. Whitney Cox



Product: IFR 25 oz. Charisma; University of Indiana Musical Arts Center, Jacobs School of Music; Photo: Mike Schwandt

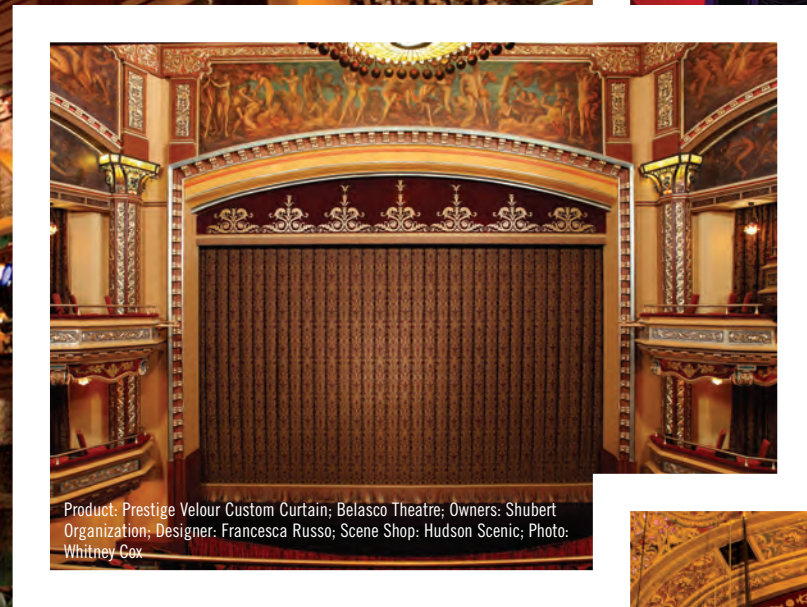

Product: Prestige Velour Custom Curtain; Belasco Theatre; Owners: Shubert Organization; Designer: Francesca Russo; Scene Shop: Hudson Scenic; Photo: Whitney Cox

Expertly Fabricated  
Custom Curtains.

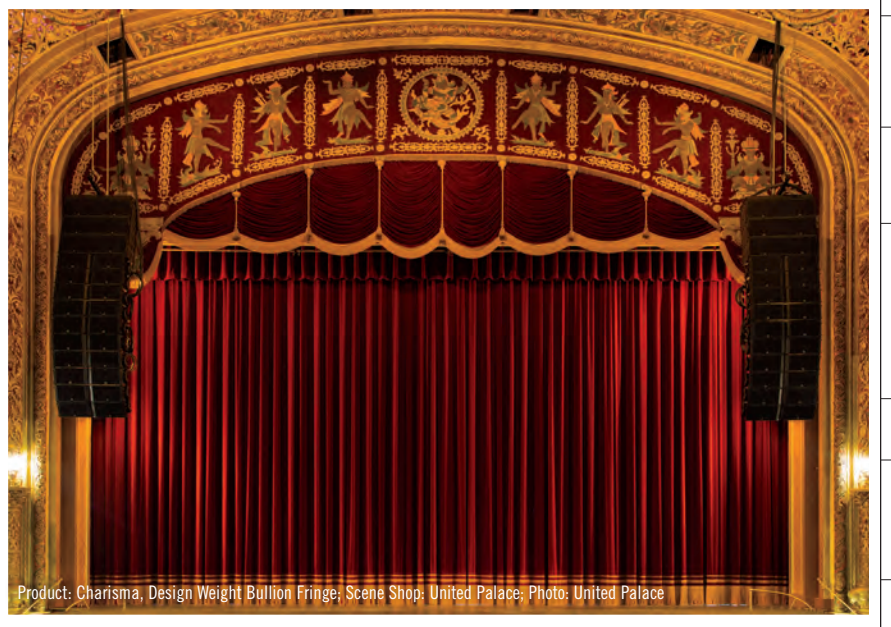

Product: Charisma, Design Weight Bullion Fringe; Scene Shop: United Palace; Photo: United Palace

- Fabrics
- Black Masking
- Custom Stage Curtains & Backdrops
- Custom Special Event Sewing
- Digital Printing
- LED Star Drops
- Pipe & Base
- Rentals
- Projection Materials
- Flooring
- Curtain Track
- Stage Equipment, FXs & Mirrors
- DMX Winches
- Scenery Props
- Shop & Production Supplies
- Tape
- Film & Video Supplies
- Index



GUIDE FOR SPECIFYING SOFT GOODS		
1	WHAT IS THE DRAPERY DESIGN	Are you building a "Grand Drape" for a proscenium, an Austrian Curtain for a special event, an acoustical banner in a concert hall or plain black stage masking – the design, application and size of the fabric will guide many of the specifications you need to make.
2	CHOOSE THE FABRIC	<p>Synthetic fabrics are typically Inherently Fire Retardant (IFR) and easily meet building codes around the world even after numerous washings. However these fibers are more prone to wrinkles and creases than natural fibers. Does the drape or hand of the fabric allow for the design you envision? Will the stretch of the fabric construction cause your drape to distort over time? Is the color you want available as a stock color in your chosen fabric or will it need to be custom dyed? Is the width of the fabric suitable for the design/construction?</p> <p>Muslin is typical for painted backdrops. Extra Wide widths allow for seamless drops to be made. Non Fire Retardant (NFR) muslin is typically preferred by painters. Narrow muslin means seams but is much less expensive. For non-painted backdrops, FR or IFR fabrics insure your goods will meet local fire codes. Specialized fabrics like scrims and synthetic wovens may also be used for special effects.</p>
3	HOW MUCH FLAT or FULLNESS	<p>Typically, draperies made with more fullness appear more luxurious, have improved acoustical characteristics and are more opaque. The amount of fullness and type of pleats or gathering will vary with the style of the design, and the width of the fabric panels.</p> <p>Seamless fabrics are used for translucent drops and wide rear projection surfaces to insure there are no sewn seams casting shadows. If using narrower fabrics that get seamed together, consider what fabric width is the most cost effective given the overall size of your backdrop.</p> <p>Typically drops are "rail-roaded" - built with horizontal seams - but in some instances you may want to specify vertical seams.</p>
4	SHOULD IT BE LINED	Is your fabric selection opaque enough for your drapery, or does it need to be lined to insure it can provide a true black out? Is the installation permanent or temporary?
5	HOW IS IT ATTACHED	Draperies can be flown, tracked, dead-hung, on rods, or rigged for opening as tabbed, Venetian, Austrian or Waterfalls. The top finish must reflect this final application. Painted backdrops are typically tied to a batten and flown and are built with tie-lines to tie around the pipe. If needed you can also specify alternate types of connections including twill, bungee cords, snap hooks or even a top hem pocket. Some soft goods may be installed in frame systems and should be laced or Velcro attached. The drop might be attached to stage mechanics like a travel track system (hooks or ties to the track carriers) or a roll drum (unfinished top taped to the drum).
6	WHAT IS THE SIDE FINISH	Will the leading edge of your drapery be seen by the audience and require a turn-back side hem? The taller the backdrop, the more likely it is that the side edges of the fabric will fold, flop or "hourglass" in. Specify a side finish which minimizes this distortion. In some cases it's necessary to create side tension to stretch the backdrop to remove wrinkles. Grommets and tie line can be used if you have rigid scenery that can be tied off to. Some rigging allows for vertical cables to hold the sides of the backdrop stretched out taut. Hoop & Loop tape is another option in some cases. You might also consider the Rose Brand Stretcher Frame to minimize hourglassing distortions.
7	HOW DOES THE BOTTOM FINISH	Bottom finish serves two purposes – to weight the fabric and stretch out any wrinkles and to "meet the stage floor" and create a clean finished look. A hem pocket for pipe is most typical, though sometimes tape with lead weights or heavy chain may be specified to allow the fabric to flow more easily. With a bottom pipe you must indicate the diameter of pipe you will use, and whether the pocket will be seen or hidden from view by a false "skirt." Also where the pipe slides into the pocket – from the edge or the middle of the drop.
8	WHEN IS YOUR DEADLINE	Tell us when you want your backdrop, but more importantly, tell us when you need it. Rose Brand is renowned for fast service and quality fabrication and we will work to meet your schedule needs no matter how crazy they are!

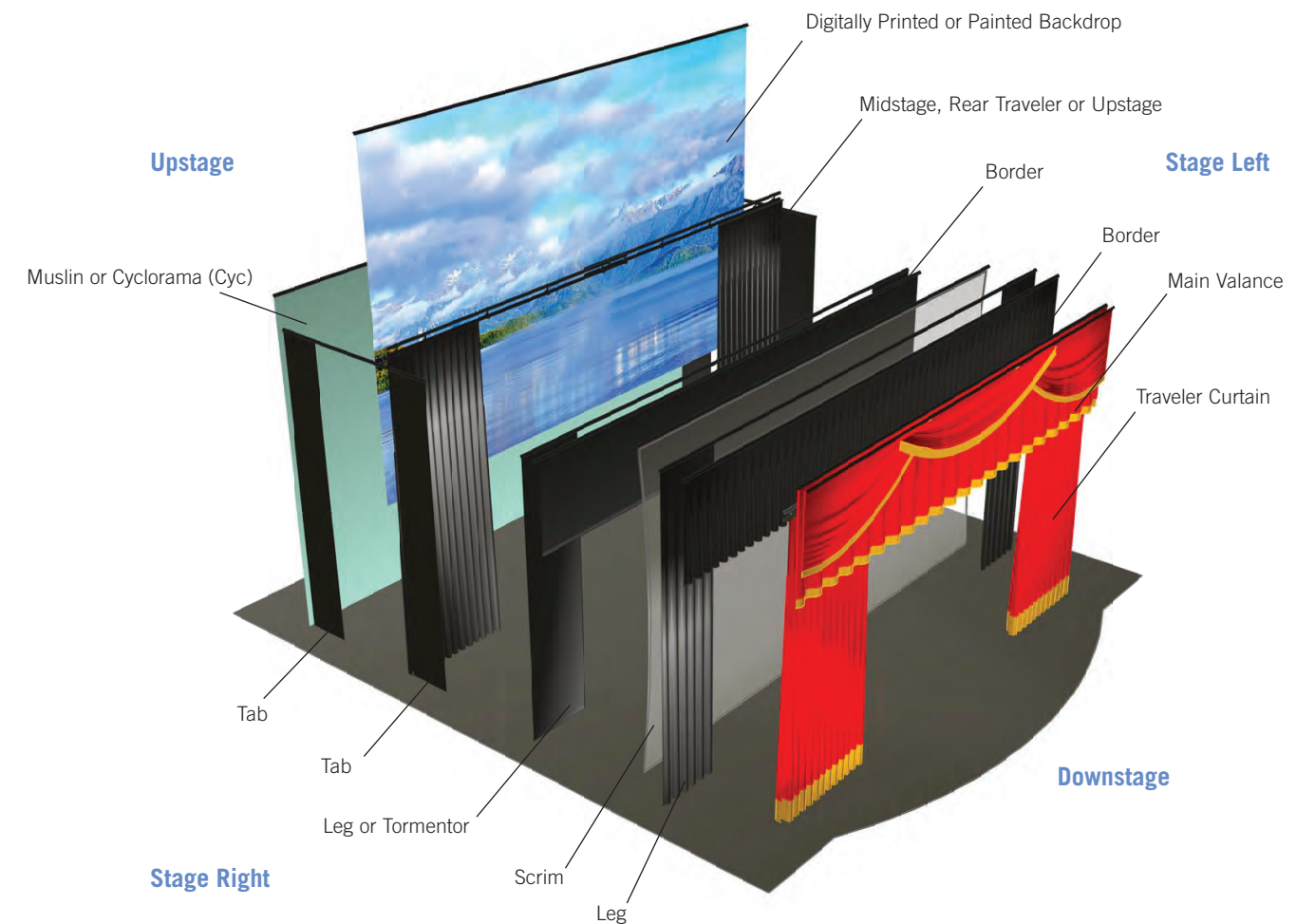

**Stage Layout**

Main Curtains (also called Proscenium, Act, Grand, Front or House) refer to the full height and valance curtains that are closest to the Proscenium opening. They are normally used to open and close the view of the stage for the audience.

Masking Curtains are typically black and designed to mask audience sight lines.

Backdrops are usually sewn flat to create a flat surface for painting, digital images or projection.

**Main Curtains**

- Main Valance or Teaser
- Main Traveler Curtain
- Tab (Tableau) Curtain (not shown) See Page 146
- Austrian Curtain (not shown) See Page 146
- Venetian Curtain (not shown) See Page 146
- Venetian Contour Curtain (not shown) See Page 147
- Roman Shade Curtain (not shown) See Page 147
- Braille Curtain (not shown) See Page 147

**Masking Curtains**

- Borders
- Legs or Tormentor
- Midstage or Rear Travelers
- Tabs

**Backdrops**

- Digitally Printed or Painted Backdrop
- Scrim
- Muslin or Cyclorama (Cyc)
- Projection Screen (not shown)
- ShowLED Star Drop (not shown)

- Fabrics
- Black Masking
- Custom Stage Curtains & Backdrops
- Custom Special Event Sewing
- Digital Printing
- LED Star Drops
- Pipe & Base
- Rentals
- Projection Materials
- Flooring
- Curtain Track
- Stage Equipment, FXs & Mirrors
- DMX Winches
- Scenery Props
- Shop & Production Supplies
- Tape
- Film & Video Supplies
- Index



## Stage Curtains

### Traveler Curtain

The Traveler, or bi-parting curtain, is made of two overlapping panels, customarily in 50-150% fullness for main curtains. The panels are hung on overlapping traveler tracks that can be operated manually or motorized.

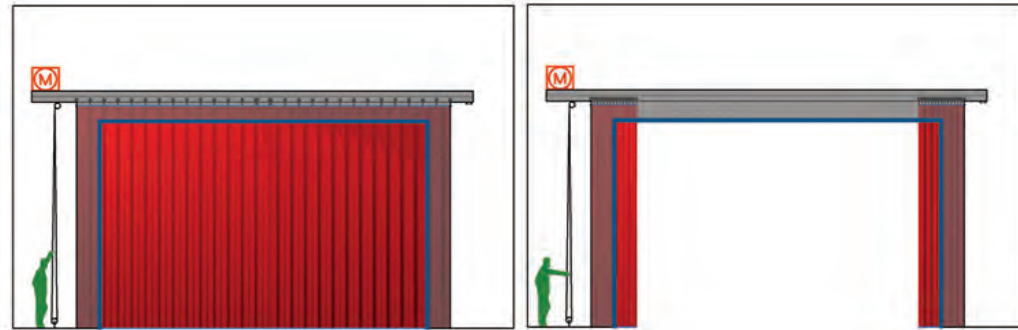

### Tab (Tableau) Curtain

The Tab Curtain is made of two overlapping panels, customarily in 50-150% fullness for main curtains. Rings are sewn on the back, starting from the lower on-stage edge. An operating line is run through the rings to pull the leading edge of the curtain out and open to create a curved swag.

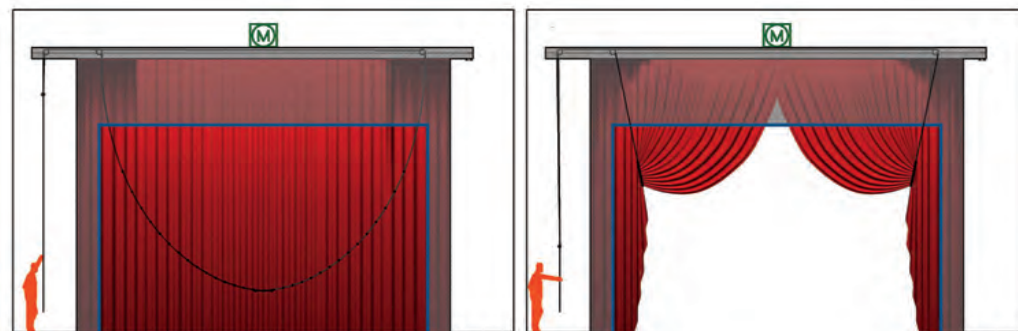

### Austrian Curtain

An Austrian Curtain is made of a series of vertical panels with both horizontal and vertical fullness. The curtain is raised evenly from the bottom by a series of lift lines that run through rings sewn on the seams between panels. Except for the lightest of fabrics, Austrians should be motorized.

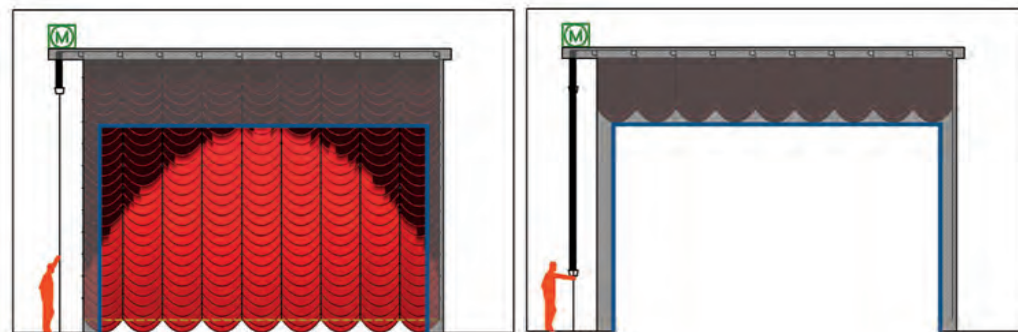

### Venetian Curtain

When in its lowered position, a Venetian Curtain looks like a standard drape in fullness. Ring and lift lines are placed on the seams. The lift lines raise the Venetian from the bottom to form a graceful, scalloped profile.

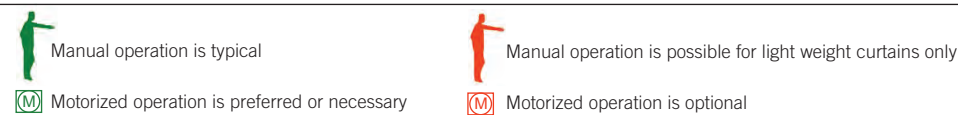
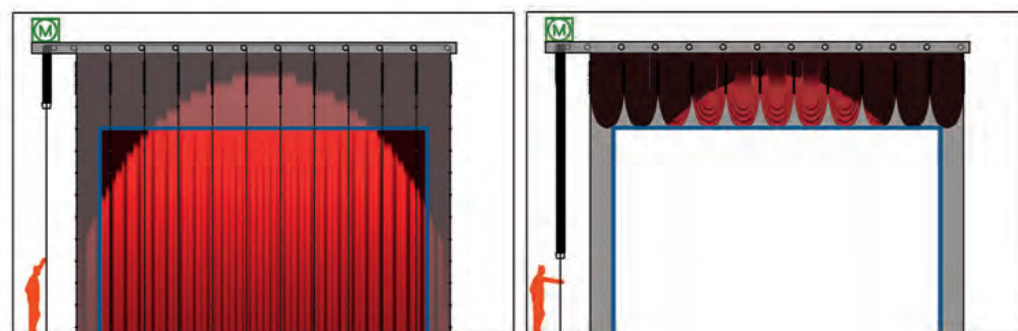

### Venetian Contour Curtain

The Venetian Contour has individually operated lift lines that allow for multiple contoured profiles. The shape of the profile is dependent on the placement of the ring lines and the fullness of the curtain. Fullness varies by panel to accommodate the contour shape. A motor is needed for each lift line.

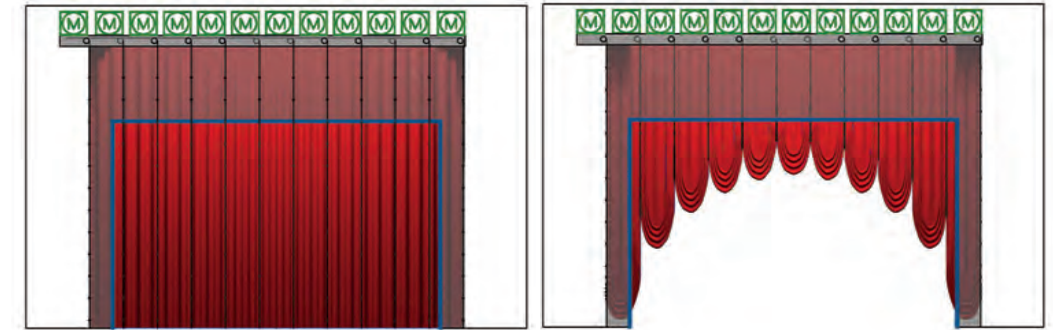

### Roman Shade Curtain

The Roman Shade is a flat curtain, built with horizontal pulls of fabric with pipe pockets on the back at the seams. Not ideal for fabrics with nap. A series of ropes or cables, run through rings on the back at the pipe pockets, lift the pipes in sequence, creating horizontal accordion folds in the curtain as the bottom is raised. A motor may be required for large heavy curtains.

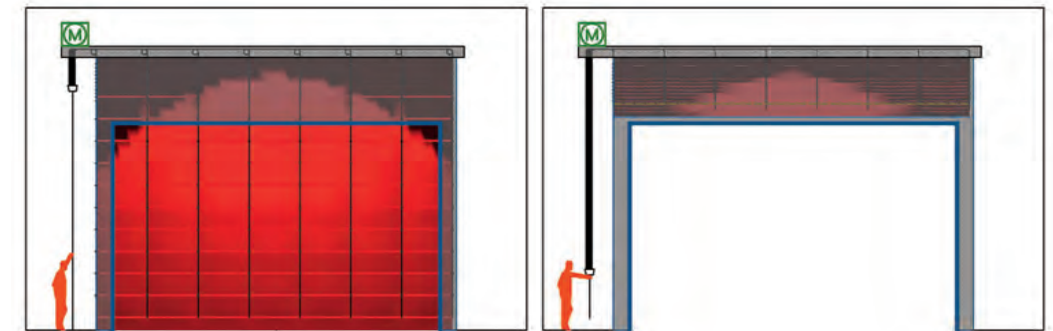

### Brail Curtain

The Brail Curtain is a flat curtain, built with vertical pulls of fabric. Rings are sewn into the seams on the back. A single pipe at or near the bottom is raised by a series of ropes or cables that are run through rings. The fabric folds onto itself as the pipe is raised. A motor may be required for large heavy curtains.

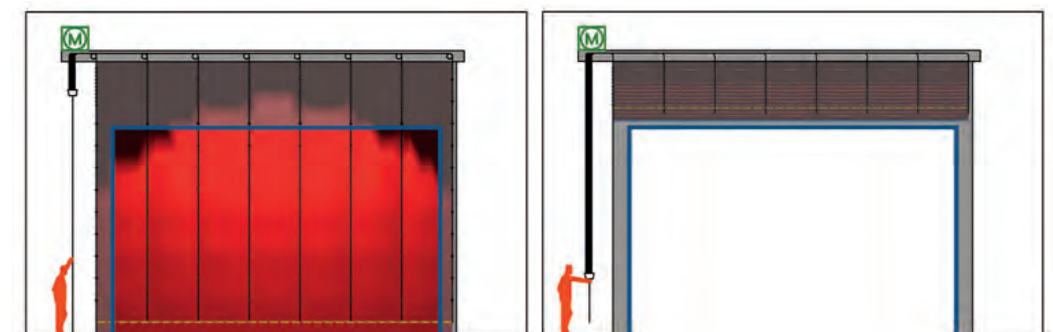



**Curtain Fullness**

Curtains can be flat or they can have fullness. Fullness is the extra fabric used across the width or sometimes height of the drape. Fullness provides a drape with a richer look. It increases the visual depth of field and provides more light and sound absorption.

**How Much Fullness**

The use, look and budget can help determine how much fullness should be added to a drape. Another consideration is whether seams need to be 'hidden' within the pleat.

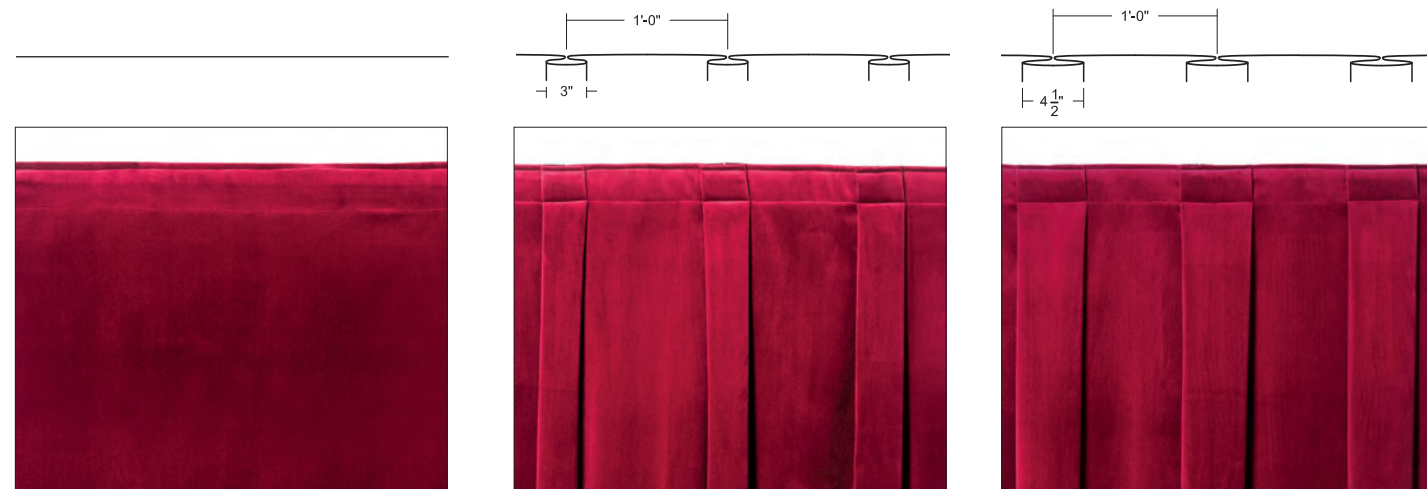

**Flat or 0% Fullness**

Curtains are sewn flat with a single or many widths of fabric seamed edge to edge. Some uses of flat curtains are drops, cycloramas (cycs) and maskings.

**50% Box Pleats**

A drape with 50% fullness uses 1.5 times more fabric than the finished width of the curtain.

**75% Box Pleats**

A drape with 75% fullness uses 1.75 times more fabric than the finished width of the curtain.

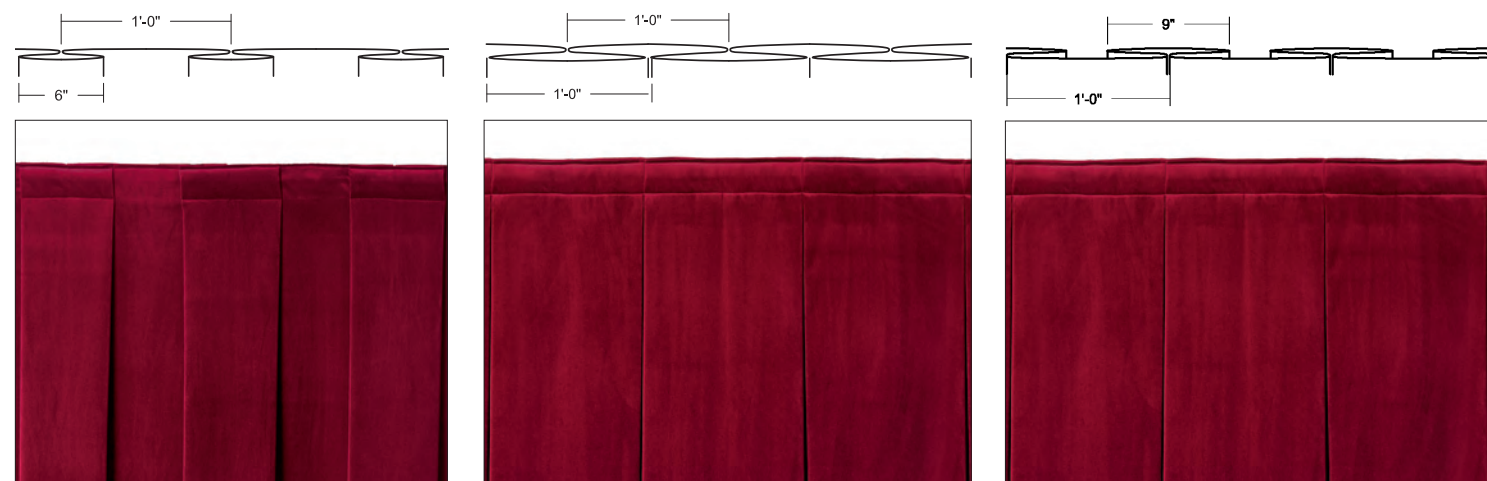

**100% Box Pleats**

A drape with 100% fullness uses 2 times as much fabric as the finished width of the curtain.

**200% Box Pleats**

A drape with 200% fullness uses 3 times as much fabric as the finished width of the curtain. It is most commonly used for Main Curtains where a rich, full look is desired.

**150% Inverted Box Pleats**

An inverted pleat puts the fullness at the back of the drape. This uses less fabric, but gives the curtain a flat, smooth face, similar to a curtain with 200% fullness.

**Curtain Fullness Types**

Fullness can be manufactured into a drape using a variety of different kinds of pleats or shirring. It can also be "hung in" using Ripplefold (i.e., roll-pleats) or Pipe and Grommet.



**Box Pleats**

Box pleats create a tailored look and are the most common way to add fullness to a drape. Attachment hardware is placed in the center of each pleat. Typically, drapes are pleated on 12" centers.

**Shirring**

Most successful in fabrications with 150% - 200% fullness. Used with light to medium weight fabrics or sheers. Shirring produces a soft, even fullness.

**Knife Pleats**

This treatment gives a less tailored look than a box pleat, yet a crisper look than shirring. Like shirring, it distributes the fullness evenly across the width of the drape.



**Pinch Pleats**

Pinch pleats are the most decorative heading. They are often used in front of house locations or windows. They're normally installed with drapery hooks.

**Ripplefold Curtain**

Ripplefold curtains have roll pleats with 120% fullness. Snap tape is sewn to the top of a flat drape and then attach it to a Ripplefold track. Best when used with light or medium weight fabrics. Often used for commercial applications or contemporary interiors.

**Pipe and Grommet**

Large grommets are evenly spaced on a flat curtain that's made wider than the opening it will cover. Fullness is then created as the drape is gathered when installed on a pipe.



## Top Finishes

Our most common top finish is 3" polypropylene webbing in either black or white. Jute webbing is generally used on natural fiber fabrics such as scrims and muslins.

The top finish attachment hardware is determined by how it will be hung and what it will hang from e.g., will it be dead hung (stationary) or on a track. Another factor is sight line of the audience and if the header will be seen.

Photos are taken from the back of the drape to show detail.

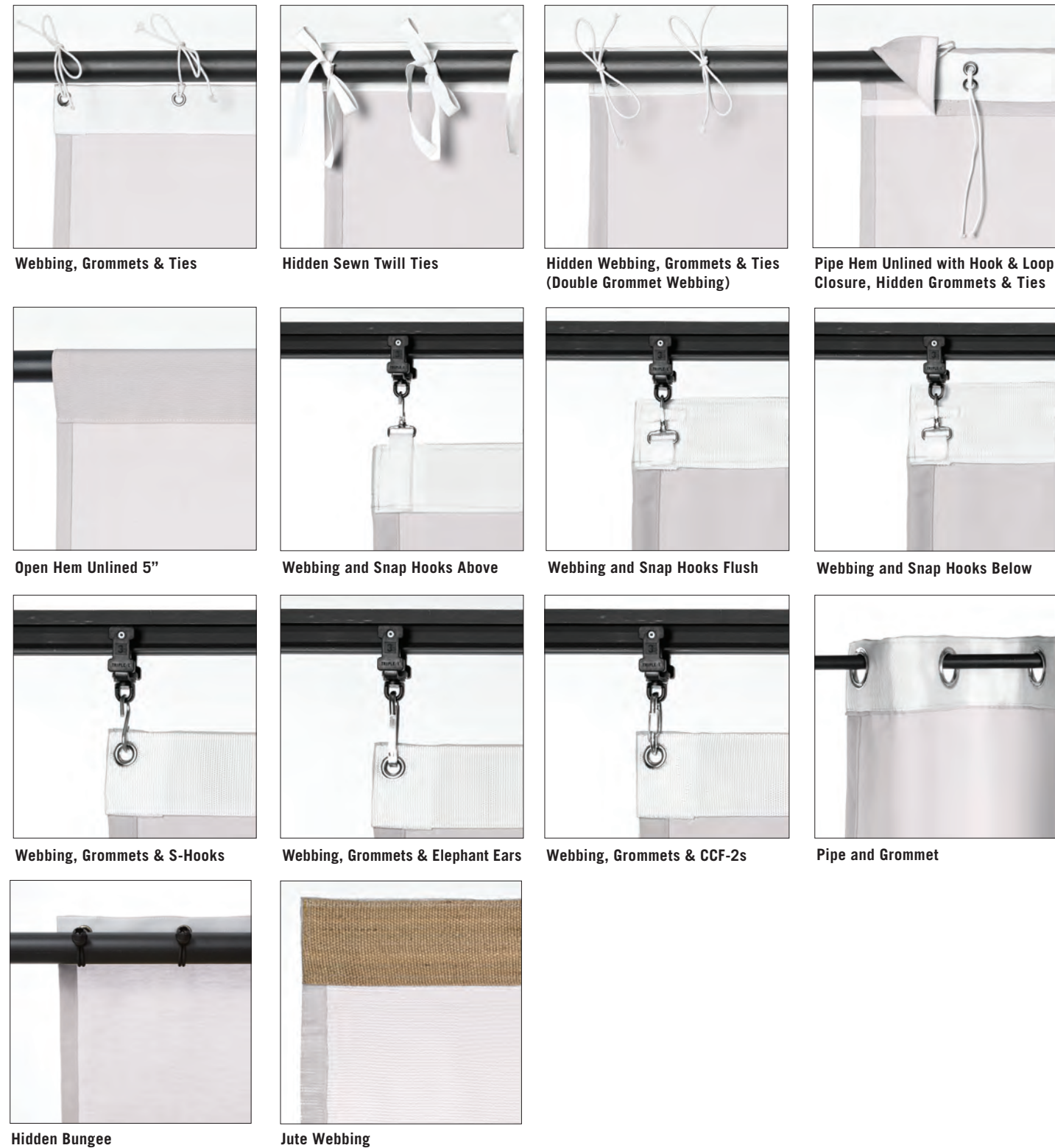

## Side Finishes

Side finishes for the leading edge of travelers are often finished with a width or half width turnback. This helps prevent the audience from seeing the back or lining of the curtain. Turnbacks can also be laced to the lining, instead of sewn, to allow for varying humidity reactions of the face and lining fabrics.

Side finishes can also be as basic as a flat 2" hem. Hook and Loop can be used if drapes are attaching to each other or to a frame.

For pieces that need tension on the sides, cable guides or cable hems can be used. For fabrics with stretch, grommet patches are often the best option.

Photos are taken from the back of the drape to show detail.

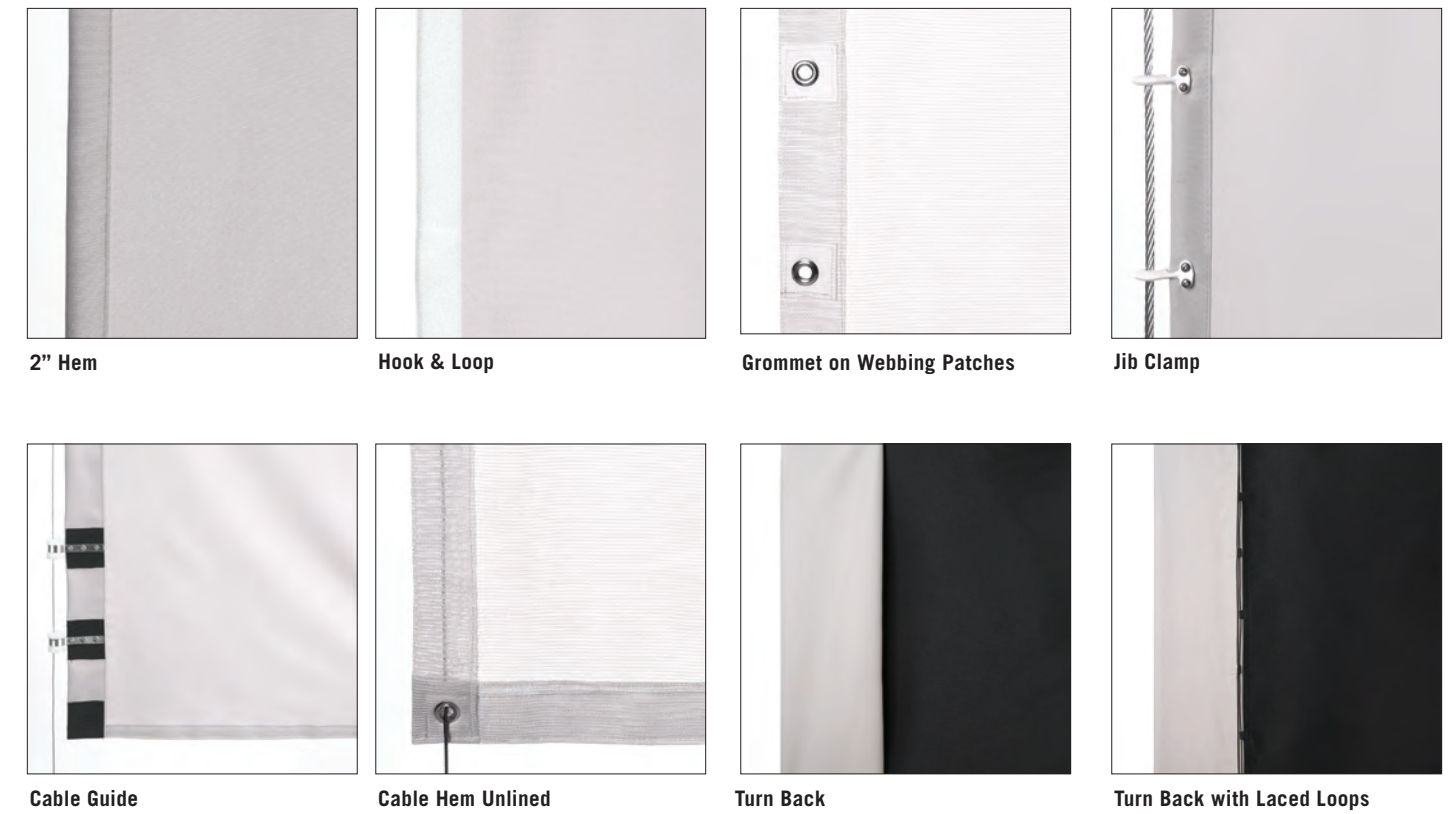

## Top Finish Hardware

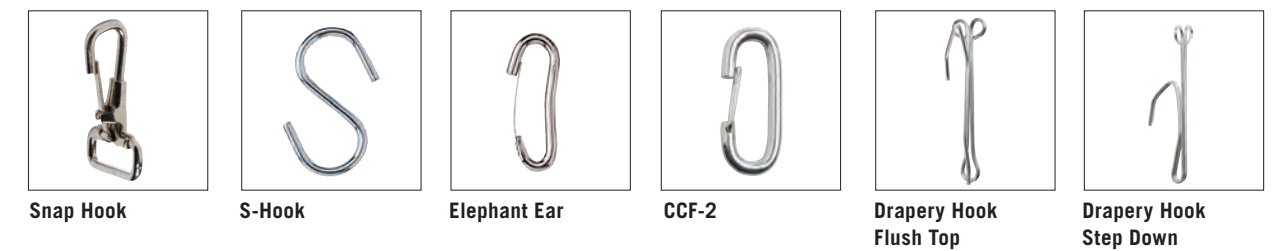



## Bottom Finishes

Photos are taken from the back of the drape and cut away to show details.



### Chain Hem Lined 5"

Creates a nice hang for flat drapes or those with fullness. The chain weight is suspended in a separate pocket within the hem.



### Hem Tape Weight 4"

For lighter weight fabric or when a crisper bottom hem is desired.



### Hem BB Weight

For lightweight fabrics.



### Open Hem Unlined 5"

Used with flat drapes, scrims and cycs. Creates a clean, straight visual line. This hem can be unlined or lined.

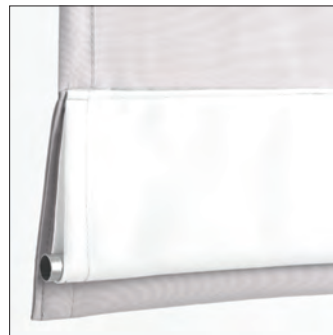

### Pipe Pocket with Skirt 5"

The slightly longer skirt is used to prevent light leaks from under the pipe and compensate for uneven floors.



### Open Hem 5" with 3" Pipe Pocket Above

This hem is also used to prevent light leaks from under the pipe and compensate for uneven floors.



### Pipe Hem Lined with Feed Slit

Often placed in the center or every 10' to ease the installation of the bottom pipe.

## Drape Bag



### Drape Bag

Our drapes ship in our Rose Brand Drape Bag (some size and quantity exceptions).

## Burn Sample



### Burn Sample

A burn sample is sewn into the top webbing or side seam of a drape to facilitate flame testing.

## Swags & Jabots



### Austrian Swag

Like an Austrian Curtain, the swag has fullness both vertically and horizontally.



### Scalloped Swag

The fullness in this swag is evenly spaced, forming arcs radiating out from the center.



### Point to Point Swag

The fullness in this swag is pulled to the outer corners, leaving the center of the swag flat.



### Shirred Swag

Shirring tape is used on the header to create the fullness in the swag.



### Jabots

Jabots, sometimes called waterfalls, are fabric panels that typically cascade down the side of, or between, swags. They often have a complementary fabric as a liner or fringe down their leading edge.

## Linings

Linings help protect the back of a curtain, increase sound absorption and increase opacity of the curtain. They are typically sewn into the top webbing and sides, but can also be fully removable with hook and loop for ShowLED Star Drops.



### Unlined

An unlined curtain is a single layer of fabric.



### Liner - Flat

Typically, a flat liner is used on a flat drape. However, it can also be put behind a drape with fullness. This is an option when space is limited, as with flying curtains, or if a removable lining is desired.



### Liner - Full

Both the face and the lining fabric have fullness. This creates a rich drape with the highest light and sound absorption.



### Double Faced or Self Lined

A curtain is made 'double faced' when face fabric is used on both sides. Front of house drapes are often double faced as they will be seen from both sides.



# Tassels, Trim & Fringe

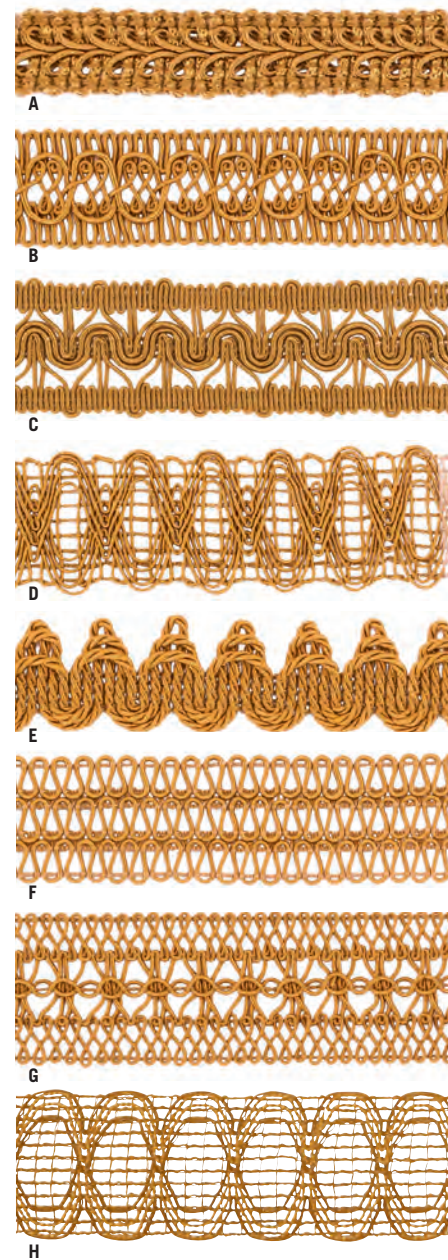

## DESIGNER TRIM

Available in Antique Gold and Bright Gold.

	Price Per Yard
A. ½" Ripple Trim	2.05
B. 1¼" Raised Circle 2" Raised Circle	3.25 4.75
C. 1½" Lupe Trim 3" Lupe Trim	4.00 7.50
D. 1½" Wave Trim 3" Wave Trim	4.00 7.00
E. 1½" Serpentine	5.00
F. 1½" Zipper Trim 3" Zipper Trim	4.00 7.50
G. 1½" Filigree	4.00
H. 1½" Buckle 3" Buckle	4.00 7.50

Rose Brand's extensive lines of tassels, fringe and trims span the decorative spectrum from rich and opulent to classical, art deco, and modern. We are constantly updating our collections to insure that we offer shades and styles that help you create beautiful treatments.

We can also provide custom or oversized tassels and trim. Send us a sketch of the proportions you have in mind and we can suggest specific designs.

Digitally printed antique trim is also available.

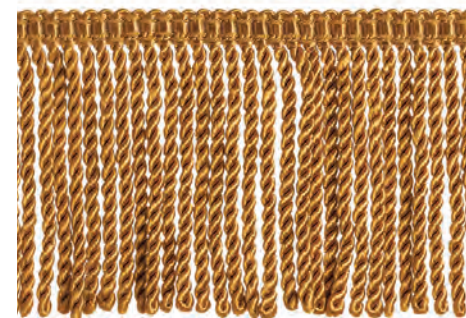

## DESIGN-WEIGHT FRINGE

Available in Antique Gold and Bright Gold.

	Price Per Yard
6" Bullion Fringe	12.00
9" Bullion Fringe	30.00
14" Bullion Fringe	68.00
20" Bullion Fringe	99.00



## CHAINETTE FRINGE

Available in Antique Gold and Bright Gold.

	Price Per Yard
4" Chainette Fringe	3.00
6" Chainette Fringe	4.50

## Antique Gold



## DESIGNER TIE-BACK TASSELS

Available in Antique Gold and Bright Gold.

	Price
A. 10" Bullion Tassel / 20" Rope	55.00
B. 10" Chainette / 18" Rope	48.00



## ANTIQUE GOLD TIE-BACK TASSELS

	Price
A. 11" Tie-Back Tassel / Molded Head and 31" Rope Spread	82.50
B. 15" Molded Head / 39" Rope	110.00

Tassels & Trim are not shown to scale. Unless otherwise noted, tassel length does not include rope or loop. Custom tassels available. Call for pricing and lead time.



## DESIGNER TIE-BACK TASSELS

Available in Antique Gold and Bright Gold.

	Price
A. 10" Bullion Tassel / 20" Rope	55.00
B. 10" Chainette / 18" Rope	48.00



## CHAINETTE TASSELS

Available in Bright Gold.

	Price
A. 10" Small Head	10.00
B. 10" Medium Head	13.00
C. 10" Large Head 12" X-Large Head	16.00 25.00
D. 24" Jumbo Head	70.00

## BRIGHT GOLD ROPE

	Price Per Yard
½" Rayon Rope	5.00
1" Rayon Rope	10.50



## CLASSIC THEATRE BULLION TASSELS

Rose Brand Classic Theatre Tassels feature a color combination of Antique and Bright Gold. The contrast brings the detail to the back of the house and the blend works well with any of our gold fringes and ropes.

	Price
12" Netted Tassel	140.00



## DESIGN-WEIGHT FRINGE

Available in Antique Gold and Bright Gold.

	Price Per Yard
6" Bullion Fringe	12.00
9" Bullion Fringe	30.00
14" Bullion Fringe	68.00
20" Bullion Fringe	99.00



## CHAINETTE FRINGE

Available in Antique Gold and Bright Gold.

	Price Per Yard
4" Chainette Fringe	3.00
6" Chainette Fringe	4.50

## Bright Gold

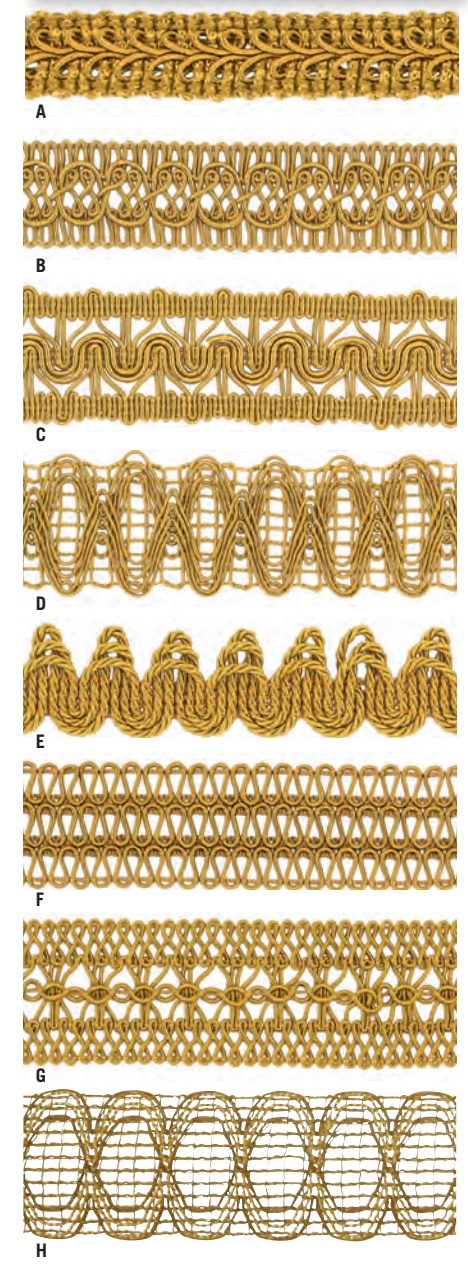

## DESIGNER TRIM

Available in Antique Gold and Bright Gold.

	Price Per Yard
A. ½" Ripple Trim	2.05
B. 1¼" Raised Circle 2" Raised Circle	3.25 4.75
C. 1½" Lupe Trim 3" Lupe Trim	4.50 7.50
D. 1½" Wave Trim 3" Wave Trim	4.00 7.00
E. 1½" Serpentine	5.00
F. 1½" Zipper Trim 3" Zipper Trim	4.00 7.50
G. 1½" Filigree	4.00
H. 1½" Buckle 3" Buckle	4.00 7.50



## Tassels, Trim & Fringe

Metallic Gold



### METALLIC GOLD TIE-BACK TASSELS

	Price
A. 9" with 3/4" Rope	80.00
B. 9" with Rayon Head / 3/4" Rope	88.00
C. 10" Double Tassels / 3/4" Rope	180.00



### METALLIC GOLD ROPE

	Price Per Yard
A. 1" Black/Gold Rope	14.00
B. 1" Rope	15.50



### METALLIC GOLD TIE-BACK CHAIR & NAPKIN TASSELS

	Price Per Dozen
A. 80" Chair Tie-Back Tassels	75.00
B. 4 1/2" Napkin Tassel	47.00

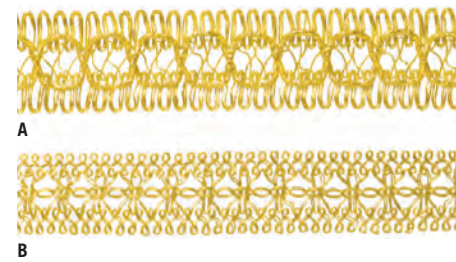

### METALLIC GOLD TRIM

	Price Per Yard
A. 1 1/4" Raised Circle	4.00
2" Raised Circle	4.75
B. 1" Filigree	2.25
1 1/2" Filigree	2.55
3" Filigree	5.00



Products: Crescent velour with customer supplied trim, applique, and tassels

## Tassels, Trim & Fringe



### SILVER CHAINETTE TASSELS

	Price
A. 10" Small Head	10.00
B. 10" Medium Head	13.00
C. 10" Large Head	16.00
D. 12" X-Large Head	25.00



### WHITE CHAINETTE TASSELS

	Price
A. 10" Small Head	10.00
B. 10" Medium Head	13.00
C. 10" Large Head	16.00
D. 12" X-Large Head	25.00



### NATURAL COTTON CHAINETTE & JUTE TASSELS

	Price
A. 10" Small Head	8.00
B. 10" Medium Head	10.00
C. 10" Large Head	12.00
D. 12" X-Large Head	25.00



### SILVER TIE-BACK CHAIR & NAPKIN TASSELS

	Price Per Dozen
A. 80" Chair Tie-Back Tassels	75.00



### SILVER ROPE

	Price Per Yard
A. 1" Metallic Silver Rope	14.00
B. 1" Silver Chainette Rope	8.25

### SILVER DESIGN-WEIGHT FRINGE

	Price Per Yard
6" Bullion Fringe	13.00



### WHITE COTTON, CHAINETTE & RAYON ROPES

	Price Per Yard
A. 1/2" Cotton Rope	4.50
B. 1" Cotton Rope	10.00
C. 1/2" Chainette Rope	6.00
D. 1" Chainette Rope	11.00
E. 1/2" Rayon Rope	5.00



### WHITE DESIGN-WEIGHT FRINGE

	Price Per Yard
6" Bullion Fringe	13.00



### NATURAL & JUTE TIE-BACK CHAIR & JUTE NAPKIN TASSELS

	Price Per Dozen
A. 80" Natural Cotton Chair Tie-Back Tassels	60.00
B. 80" Jute Chair Tie-Back Tassels	60.00

Tassels & Trim are not shown to scale. Unless otherwise noted, tassel length does not include rope or loop. Custom tassels available. Call for pricing and lead time.



# Fire Curtains

## Why Take Chances?

Call Now for a  
Certified Technician  
800-223-1624



## TOP REASONS FOR USING FIRE SAFETY CURTAIN SYSTEMS

Up to 30 minutes fire and smoke protection.

Designed as a fire and smoke barrier separating the stage from the audience.

Provides theatre patrons extra time to safely evacuate.

Protects your theatre assets.

Enables you to pass building code inspections.



Venue: Jacobs Theatre; Photo: Jesse Adams

Rose Brand Fire Curtains provide a fire and smoke barrier that separates the stage house from the auditorium. In the event of a fire, the fire curtain automatically descends to provide theatre patrons extra time to safely evacuate.

Local building and fire codes vary and require different types of fire protection. Most states use a modified version of the National Fire Protection Association's code (<http://www.nfpa.org/>). All Rose Brand Fire Curtain systems are designed, manufactured and installed according to NFPA80 and ANSI E1.22 standards. We use 40 oz., NON-ASBESTOS, high temperature coated fiberglass fabric, available in beige or black.

The two most common Fire Curtain installations are Straight Lift and Brail Lift systems. The Straight Lift Curtain is rigged to always hang flat, so it requires a large fly space above the proscenium for storage. The Brail Lift Curtain requires much less space. It's rigged similar to an Austrian curtain to gather in pleats above the proscenium.

Please contact us for a custom Fire Curtain System that meets your requirements.



### HEAT BORDER

Black fiber glass cloth vermiculite coated heat borders for protection from hot stage lights, in stock sizes for immediate shipment. Borders have finished edges with grommets and ties at the top. Conforms to the requirements of ASTM E119 (NFPA 251), ASTM E84 (NFPA 255), and NFPA 701.

	Price
1'6" high x 10' wide	145.00
2'11" high x 10' wide	175.00
2'11" high x 15' wide	260.00



Protection from heat, smoke, and flame is critical.



Fire Safety Curtains are a Key Component in your Fire Safety System.

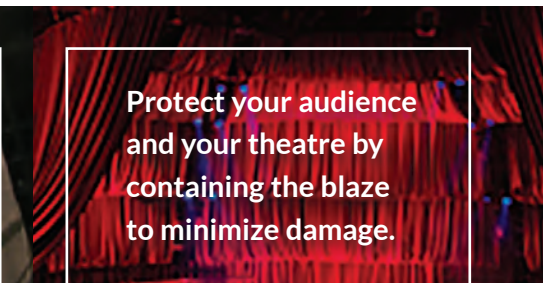

Protect your audience and your theatre by containing the blaze to minimize damage.

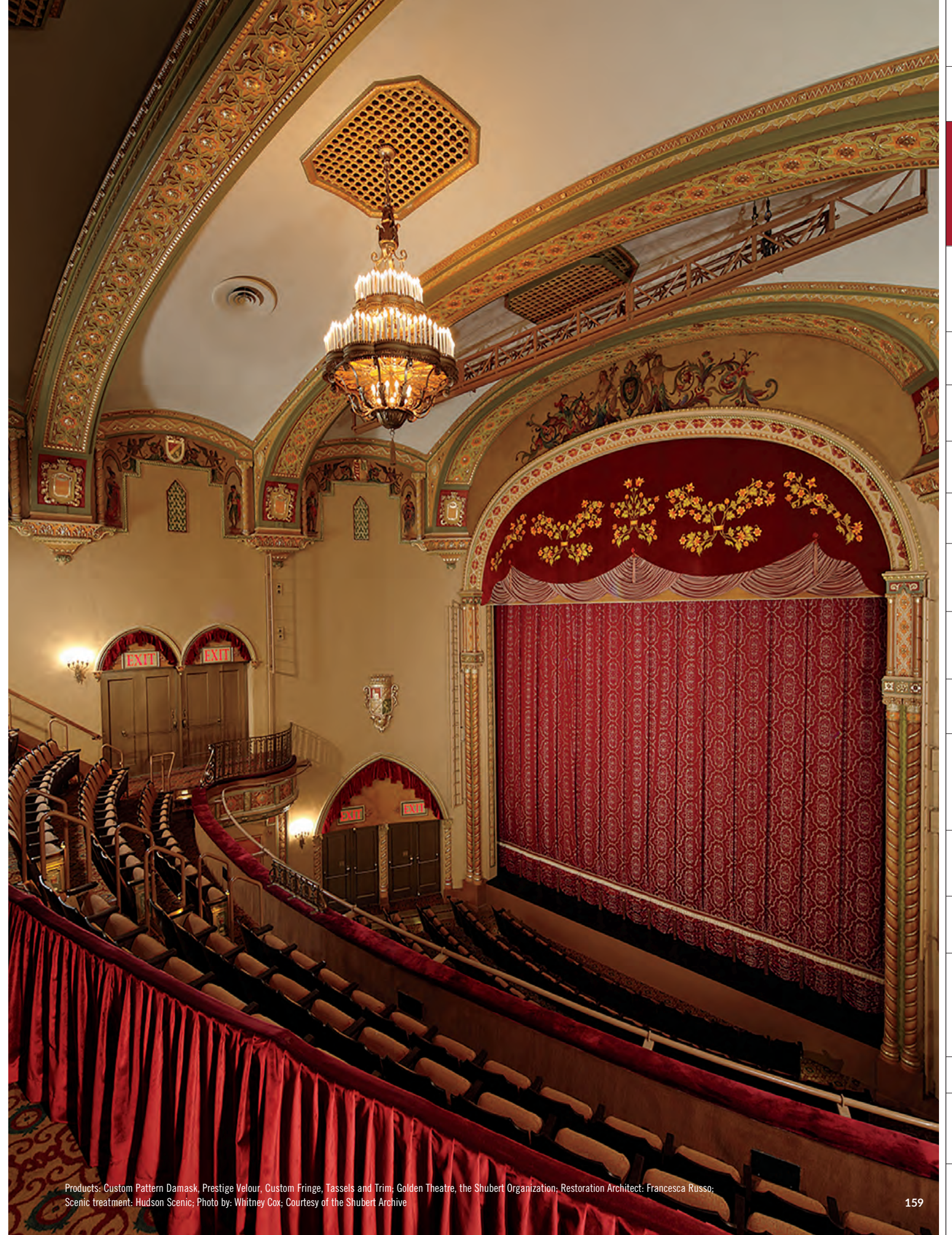

Products: Custom Pattern Damask, Prestige Velour, Custom Fringe, Tassels and Trim; Golden Theatre, the Shubert Organization; Restoration Architect: Francesca Russo; Scenic treatment: Hudson Scenic; Photo by: Whitney Cox; Courtesy of the Shubert Archive

- Fabrics
- Black Masking
- Custom Stage Curtains & Backdrops
- Custom Special Event Sewing
- Digital Printing
- LED Star Drops
- Pipe & Base
- Rentals
- Projection Materials
- Flooring
- Curtain Track
- Stage Equipment, FXs & Mirrors
- DMX Winches
- Scenery Props
- Shop & Production Supplies
- Tape
- Film & Video Supplies
- Index



# Custom Special Event Sewing

- Custom Fabric Constructions .....162
- Precision Cut Fabrics.....164
- Custom Jacquard Fabric.....166
- Chain Curtains .....168
- String Curtains .....170
- Metal Beaded Curtains.....174
- Rain Curtains .....176
- Custom Rain Curtains .....177
- Designer Vinyl by the Roll .....177
- Designer Rain Curtains.....178
- Stretch Shapes .....180**
- Splats .....180
- Columns .....182
- Stretch Walls.....183
- Rectangles & Circles.....184
- Geometric Display Walls.....185
- Winter Series .....186
- Truss, Pipe & Base Covers and Installation Accessories .....187



- Fabrics
- Black Masking
- Custom Stage Curtains & Backdrops
- Custom Special Event Sewing**
- Digital Printing
- LED Star Drops
- Pipe & Base
- Rentals
- Projection Materials
- Flooring
- Curtain Track
- Stage Equipment, FXs & Mirrors
- DMX Winches
- Scenery Props
- Shop & Production Supplies
- Tape
- Film & Video Supplies
- Index



# Custom Fabric Constructions

Product: Jubilee Satin; P!nk Tour; Set Design and Lighting Design: Baz Halpin / Silent House Productions; Director: Baz Halpin / Silent House Productions; Photo: Todd Kaplan

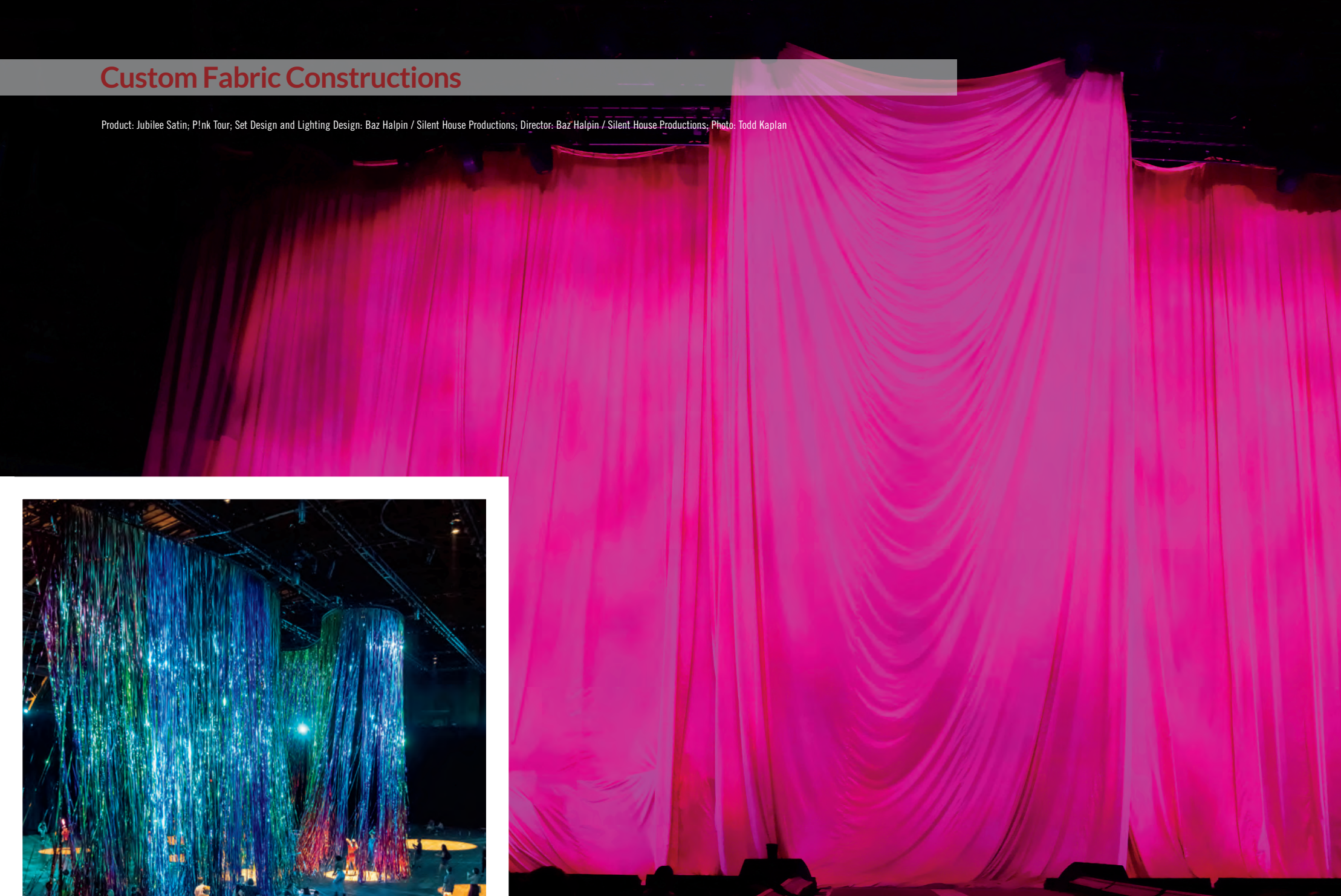

Product: Chiffon; New York City Opera Lincoln Center - New York State Theatre; Design: David Stark; Design & Production; Photo: Joe Fornabai



Product: String Curtains; Ethan Stiefel's *Frontier*, *The Washington Medal*; Photo: media4artists - Theo Kossenias; For full credits, see page 171.



Products: Rain Curtains; Custom Curved Track and Installation Services; *The Left* by Nick Cave at Park Avenue Armory, June 2018; Director of Production: Paul King; Photo by James Prinz Photography. Courtesy of the artist and Jack Shainman Gallery, New York.



Product: FR Rip Stop Nylon; Pan American Games; Design Firm: Five Currents LLC; Lighting and Projection: PRG; Photo: Kris Dekeijser

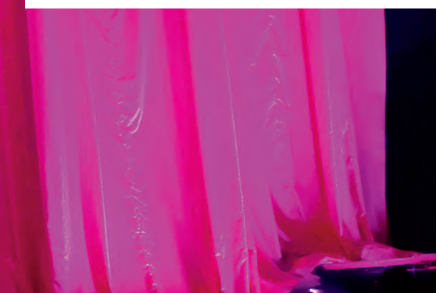
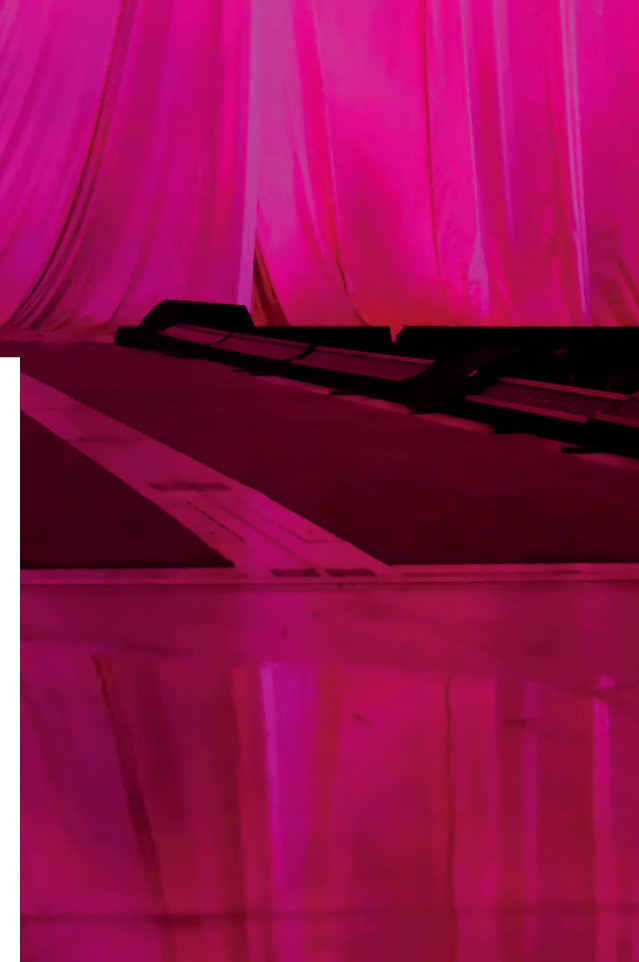

Expertly Fabricated Custom Curtains.



Product: Tergalet; The Smashing Pumpkins; Concord Pavilion, CA; Designer: Lawrence Upton; Photo: Steve Jennings

- Fabrics
- Black Masking
- Custom Stage Curtains & Backdrops
- Custom Special Event Sewing
- Digital Printing
- LED Star Drops
- Pipe & Base
- Rentals
- Projection Materials
- Flooring
- Curtain Track
- Stage Equipment, FXs & Mirrors
- DMX Winches
- Scenery Props
- Shop & Production Supplies
- Tape
- Film & Video Supplies
- Index



# Precision Cut Fabrics



Product: Precision Cut, 6 Point / Thread Sharktooth Scrim, 22 oz. Black Encore; The Milwaukee Ballet's *Beauty and the Beast*; Scenic Design: Todd Edward Ivins; The Milwaukee Ballet Scene Shop; Photo: Mark Frohna

Precision Cut Fabric offers new design possibilities for fabric backdrops, scenic elements, tent swags and ceiling covers. Precision Cut Fabrics take light beautifully, adding contrast, dimensionality and texture to any setting. Choose from our library of designs or create your own for a more custom look. With digital precision we can turn your most intricate designs into cut drops or applique.

Precision Cut Fabric is offered in a wide range of synthetics such as our Sheer, Silk, Textured and other lines. Seamless single panels in sizes up to 6' x 35' can be seamed together to create any size desired. We also offer marking capability for placement of sewing marks, part numbers, etc. Contact us early in your design process!

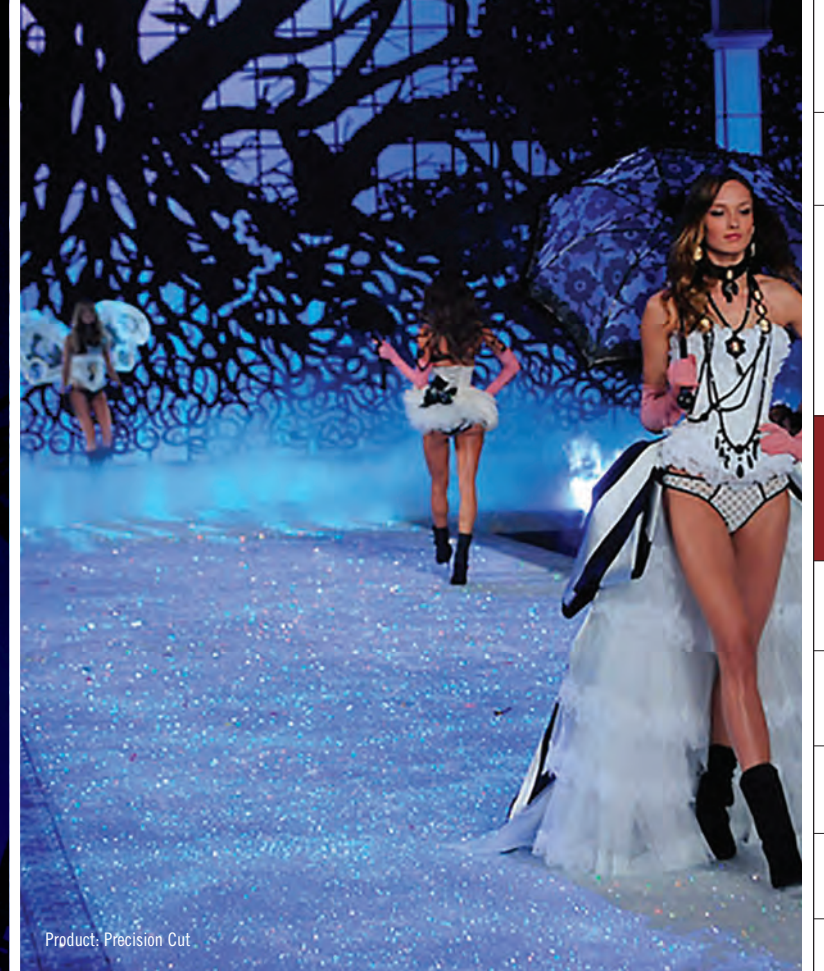

Product: Precision Cut

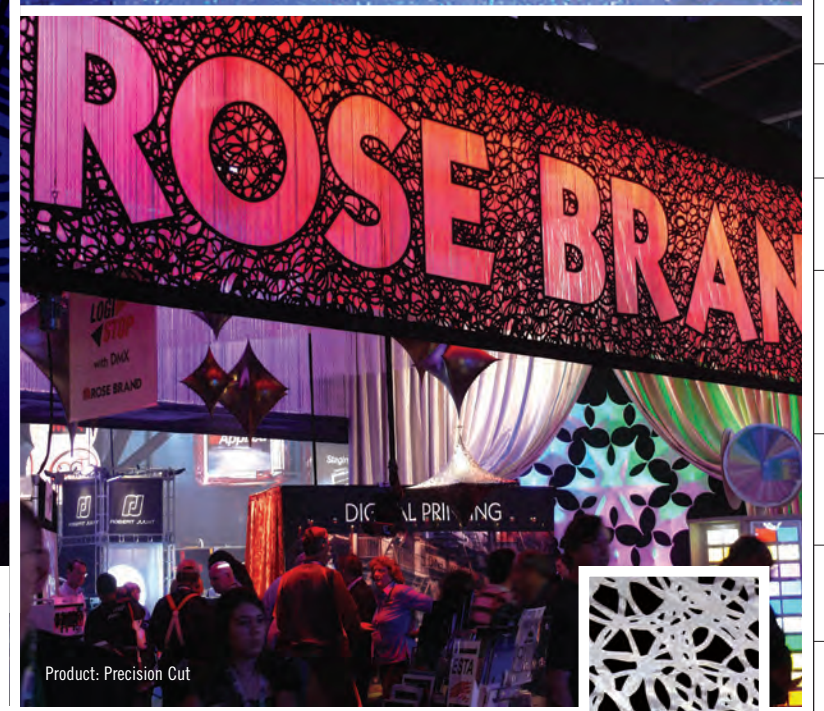

Product: Precision Cut

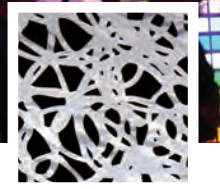

*New design possibilities for fabric backdrops.*



- Fabrics
- Black Masking
- Custom Stage Curtains & Backdrops
- Custom Special Event Sewing
- Digital Printing
- LED Star Drops
- Pipe & Base
- Rentals
- Projection Materials
- Flooring
- Curtain Track
- Stage Equipment, FXs & Mirrors
- DMX Winches
- Scenery Props
- Shop & Production Supplies
- Tape
- Film & Video Supplies
- Index



## Custom Jacquard Fabric



### Evening of SeriousFun Celebrating the Legacy of Paul Newman

SeriousFun Children's Network founded by Paul Newman provides free summer camps and programs for children with life-threatening diseases from more than 50 countries.

Product: Jacquard; An Evening of SeriousFun, NY – Avery Fisher Hall and LA – The Dolby Theatre; Designer: Polly Wood-Holland; Photos: Peter Finder and Polly Wood-Holland

The sets for these star-studded galas in New York, Los Angeles and London were designed by Polly Wood-Holland. Polly has been designing for the Paul Newman charity shows since 2004. For this year's galas she conceived this beautiful Custom Jacquard backdrop. Her design is subtle and playful, and her choice of grey tones allowed for fabulous front and backlighting effects.

Rose Brand's Jacquard fabrication allows a designer to create a custom fabric with intricate patterns and imagery. With this incredible technique your custom artwork is not printed, but digitally woven into the fabric itself. The result is luxurious and textured with depth and interplay of sheer and opaque.

Maximum width of image: 86 inches. Art repeat: 16 feet. 55 yard roll minimum.



*Rose Brand's Jacquard fabrication allows a designer to create fabric with intricate custom patterns and imagery.*



Fabrics
Black Masking
Custom Stage Curtains & Backdrops
Custom Special Event Sewing
Digital Printing
LED Star Drops
Pipe & Base
Rentals
Projection Materials
Flooring
Curtain Track
Stage Equipment, FXs & Mirrors
DMX Winches
Scenery Props
Shop & Production Supplies
Tape
Film & Video Supplies
Index



# Chain Curtains

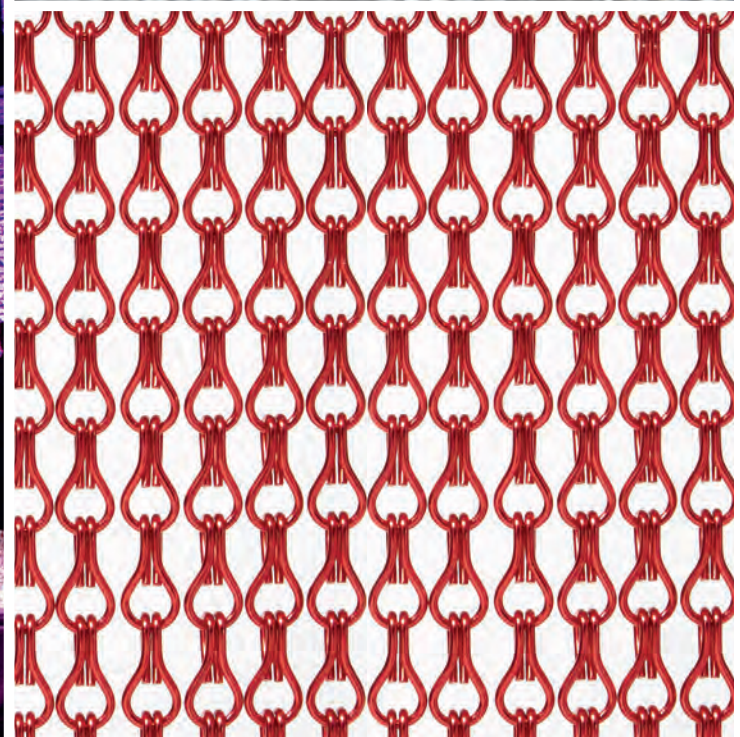
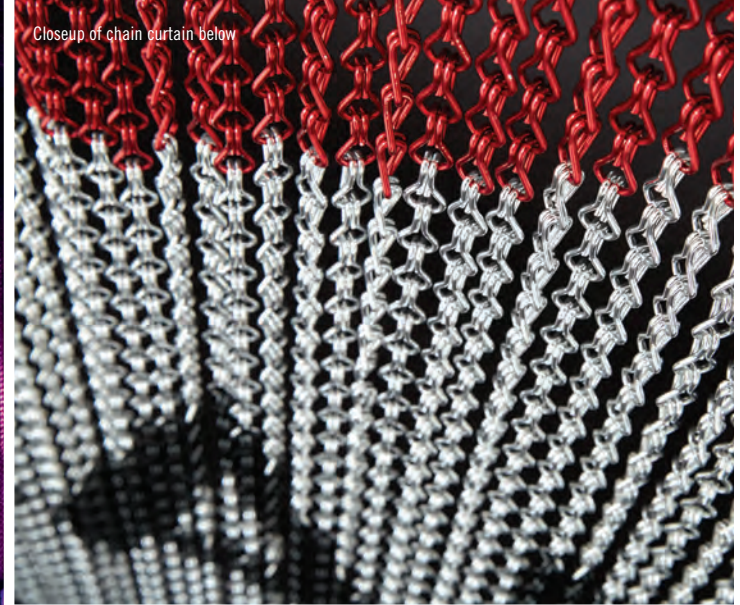

Light, bright, and versatile. 100% Aluminum Chain Curtains are custom made from a choice of 11 vibrant colors.

Great for Events, Exhibitions, Trade Show Booths, Retail Display, Architectural Treatments, Themed Environments, Museums, Restaurants, Art Shows, and Theatre. Chain Curtains create a visually open space divider that can be dramatically lit and projected on. Solid, Striped or with Custom Graphic Designs.



Product: Chain Curtain; Venue: Cedar Lake; Designer: Hudson Gray, Inc.; Photo: Hudson Gray, Inc.

## CHAIN CURTAINS

**Flame Retardant.** Available in 11 vibrant colors. Black, Gun Metal, Silver, Bright Gold, Platinum, Antique Gold, Fuschia, Scarlet, Lilac, Sapphire, Pine. Call for custom quote.

55 yd. continuous length  
 Solid Color Curtain  
 Striped Curtain  
 Graphic Image Curtain

### Price

95.00  
 Call for Pricing  
 Call for Pricing  
 Call for Pricing



Product: Chain Curtain 8' H x 7'2" W used for tradeshow

Fabrics
Black Masking
Custom Stage Curtains & Backdrops
Custom Special Event Sewing
Digital Printing
LED Star Drops
Pipe & Base
Rentals
Projection Materials
Flooring
Curtain Track
Stage Equipment, FXs & Mirrors
DMX Winches
Scenery Props
Shop & Production Supplies
Tape
Film & Video Supplies
Index



# String Curtains



Product: String Curtains; *Urban Nutcracker*, John Hancock Hall; Scenic Designer: Janie Howland; Lighting & Projection Designer: Scotty Clyve; Scene Shop: Wooden Kiwi Productions; Photo: Scott Clyve

String Curtains are design classics that evoke a playful, yet elegant statement. They offer a unique interaction of light and shadow that creates an interesting room divider, decoration or attention-getter.

Maximum height of 20'. Top finishes: hidden webbing, grommets and ties, open pipe hem, or hook & loop.

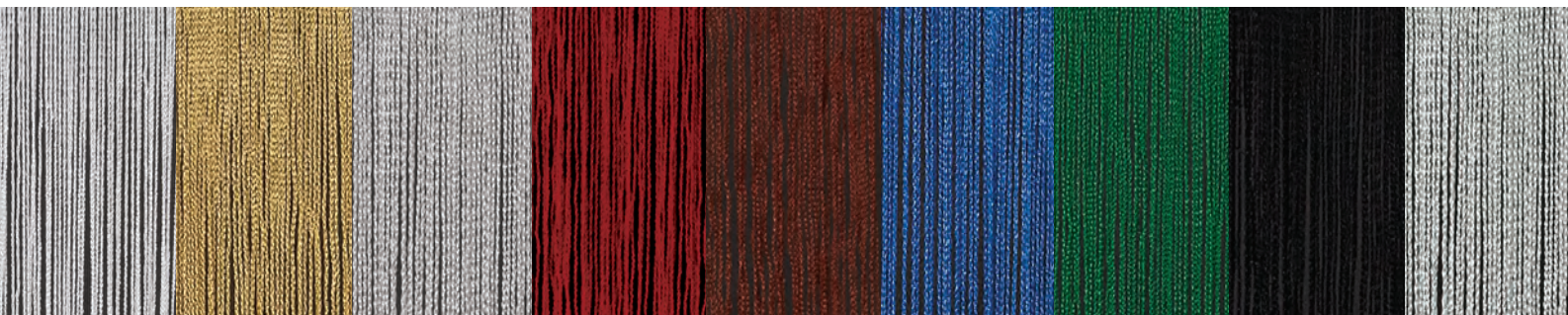

Snow White Bullion Gold Moonlight Silver Regal Red Earth Brown Royal Blue Emerald Green Carbon Black Slate *New Color*

## STANDARD STRING CURTAINS

**Inherently Flame Retardant.** Our classic style is offered in 8 alluring colors. Available in 5' widths and custom heights up to 20'. See colors to left.

	Price Per Square Foot
Up to 5' High Panels	5.00
5'1" High to 8' High Panels	4.00
8'1" High to 20' High Panels	3.50



Product: String Curtains; 59th FIFA Congress, Atlantis, Nassau Bahamas; Producer: Hudson Theatrical Associates/ Rufener Events; Designer: Jesse Poleshuck; Lighting Designer: Brian MacDevitt; Photo: Ryan Trupp



Product: 156 panels of Black Premium Trevira CS String Curtains; Cincinnati Museum of the Art; Photo: Ryan Kurtz

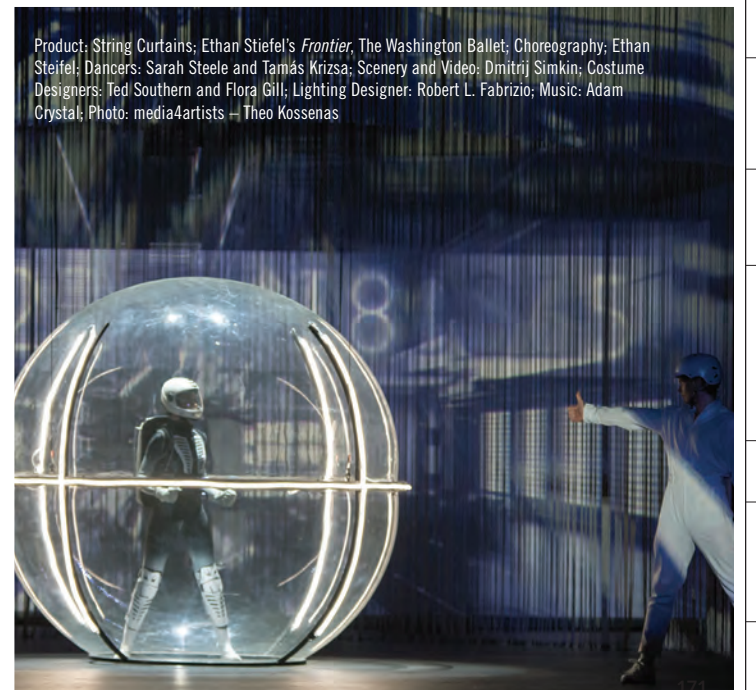

Product: String Curtains; Ethan Stiefel's *Frontier*, The Washington Ballet; Choreography: Ethan Stiefel; Dancers: Sarah Steele and Tamás Krizsa; Scenery and Video: Dmitriy Simkin; Costume Designers: Ted Southern and Flora Gill; Lighting Designer: Robert L. Fabrizio; Music: Adam Crystal; Photo: media4artists - Theo Kossenias

- Fabrics
- Black Masking
- Custom Stage Curtains & Backdrops
- Custom Special Event Sewing
- Digital Printing
- LED Star Drops
- Pipe & Base
- Rentals
- Projection Materials
- Flooring
- Curtain Track
- Stage Equipment, FXs & Mirrors
- DMX Winches
- Scenery Props
- Shop & Production Supplies
- Tape
- Film & Video Supplies
- Index



## String Curtains

### DESIGNER STRING CURTAINS

**Inherently Flame Retardant.** Available in 6'9" widths. Custom heights up to 50'. Minimums may apply. 11 beautiful designer colors.

<u>Neutrals</u>	<u>Price Per Square Foot</u>	<u>Colors</u>	<u>Price Per Square Foot</u>
<i>White, Beige, Silver, Black, Pewter</i>		<i>Bronze, Kiwi, Blue, Red, Sable, Gold</i>	
Up to 6' High Panels	7.00	Up to 6' High Panels	9.00
6'1" to 15' high Panels	6.00	6'1" to 15' high Panels	8.00
15'1" to 30' High Panels	5.00	15'1" to 30' High Panels	7.00



White      Gold      Beige      Silver      Black      Pewter



Bronze      Kiwi      Blue      Red      Sable

### LUREX STRING CURTAINS

**Inherently Flame Retardant.** Add sparkle to your design. Available in 5' widths. Custom heights up to 50'. Minimums may apply.

<u>Silvers</u>	<u>Price Per Square Foot</u>	<u>Golds</u>	<u>Price Per Square Foot</u>
<i>White/Silver, Pewter/Silver, Black/Silver</i>		<i>White/Gold, Pewter/Gold, Black/Gold</i>	
Up to 6' High Panels	8.00	Up to 6' High Panels	10.00
6'1" to 15' high Panels	7.00	6'1" to 15' high Panels	9.00
15'1" to 30' High Panels	6.00	15'1" to 30' High Panels	8.00

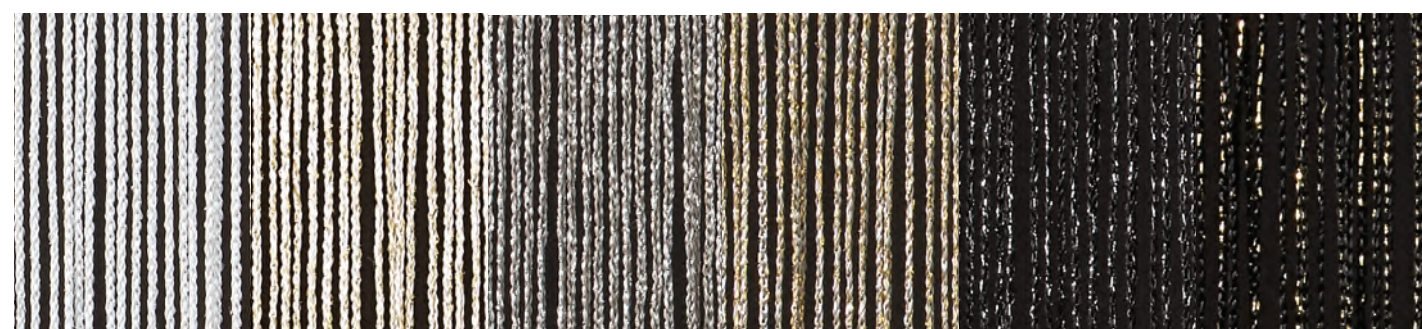

White/Silver      White/Gold      Pewter/Silver      Pewter/Gold      Black/Silver      Black/Gold



LUREX  
STRING CURTAINS

Designer, Lurex and Premium String curtains provide an elegant design solution for high end events, and permanent architectural treatments.

Great for projection and lighting effects.

Fabricated with a non-fraying construction, the bottoms can be trimmed with a scissors to any shape.

Washable up to 86° F.

### PREMIUM STRING CURTAINS

**Inherently Flame Retardant.** Twice the weight and impact when only the best will do. Available in 5' widths. Custom heights up to 50'. Minimums may apply.

Available in White and Black. Call for minimums on custom colors.

	<u>Price Per Square Foot</u>
Up to 6' High Panels	10.00
6'1" to 15' High Panels	9.00
15'1" to 30' High Panels	8.00



# Metal Beaded Curtains

BUY OR RENT



Product: Metal Beaded Curtain, *Lady Gaga and Tony Bennett New Year's Eve Performance*, Cosmopolitan Hotel, Las Vegas; Designers: Lady Gaga, Roy Bennett and Peter Aquino; Photo: Jeff Green



The stage was set for Lady Gaga and Tony Bennett's historic New Year's Eve concert at the Cosmopolitan Hotel in Las Vegas. Her fabulous design featured Rose Brand's Metal Beaded Curtains in graceful swags. These large scale faceted stainless steel beads are highly reflective for dynamic lighting effects. Contact Rose Brand for custom configurations for sale and swags for rent in several modular sizes. See Page 227 in Rentals Section for drawings.



SEE RENTALS SECTION FOR DRAWINGS

- Fabrics
- Black Masking
- Custom Stage Curtains & Backdrops
- Custom Special Event Sewing
- Digital Printing
- LED Star Drops
- Pipe & Base
- Rentals
- Projection Materials
- Flooring
- Curtain Track
- Stage Equipment, FXs & Mirrors
- DMX Winches
- Scenery Props
- Shop & Production Supplies
- Tape
- Film & Video Supplies
- Index



# Rain Curtains



Products: Rain Curtains; Custom Curved Track and Installation Services. *The Let Go* by Nick Cave at Park Avenue Armory, June 2018; Photo by James Prinz Photography. Courtesy of the artist and Jack Shainman Gallery, New York.

SEE MORE PHOTOS ON PAGE 259 READ THE FULL STORY OF "THE LET GO" ON PAGES 24-25

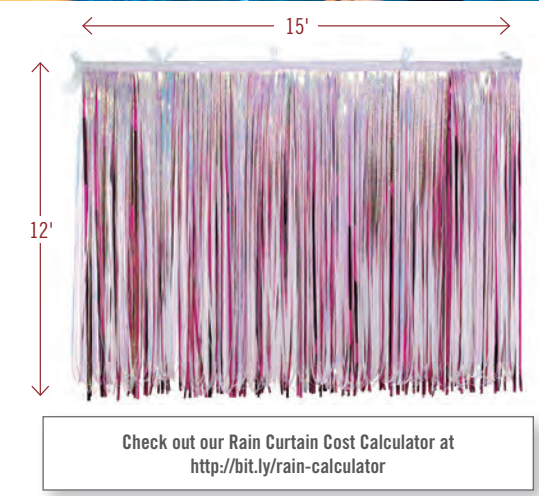

## How to Price Your Custom Rain Curtain

Example:  
 Standard 2-Layer Metallic Rain Curtain  
 12' High x 15' Wide  
 $12' \times 15' = 180'$   
 $180 \times \$1.15 = \$207.00$   
 For ties at the top, add \$2.50 per foot of width.

Custom Made Rain Curtains are usually 2-layer or 3-layer.

Check out our Rain Curtain Cost Calculator at <http://bit.ly/rain-calculator>

## Custom Rain Curtains

**METALLIC IFR** Price

				2-Layer IFR 1.15/Sq.Ft.	3-Layer IFR 2.00/Sq.Ft.
Silver	Gold	Bronze	Copper		
Moss	Green	Purple	Cerise	Red	
Ice Blue	Flag Blue	Teal	Black		

**SEMI-GLOSS IFR** Price

				2-Layer IFR 1.15/Sq.Ft.	3-Layer IFR 2.00/Sq.Ft.
Dk. Blue	Orange	Lt. Green	Red		
Lt. Blue	Orchid	Moss	White	Yellow	Pink

**CRACKED ICE IFR** Price

				2-Layer IFR 1.60/Sq.Ft.	3-Layer IFR 2.80/Sq.Ft.
Silver	Gold	Iris	Royal		
Fuchsia	Red	Emerald	Purple	White	Black

**IRIDESCENT, FLUORESCENT IFR** Price

				2-Layer IFR 1.60/Sq.Ft.	3-Layer IFR 2.80/Sq.Ft.
Iridescent Iris	Iridescent Pearl	F. Pink	F. Orange		
Neon Green	F. Lemon	Neon Orange			

**DIFFRACTION IFR** Price

			2-Layer IFR 1.95/Sq.Ft.	3-Layer IFR 3.40/Sq.Ft.
Silver	Gold	Fuchsia		

## Designer Vinyl by the Roll

1.4 mil thick. All rolls 25 yards except where noted.



**METALLIC IFR** Price  
 36" Roll 65.00  
 36" 50 yd. Roll 80.00

Available in Colors shown on the left.



**SEMI-GLOSS IFR** Price  
 36" Roll 65.00  
 36" 50 yd. Roll 80.00

Available in Colors shown on the left.

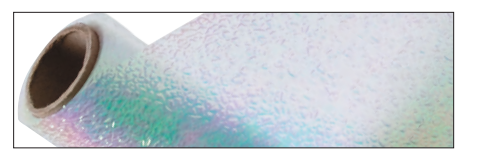

**CRACKED ICE IFR** Price  
 48" Roll 150.00

Available in Colors shown on the left.

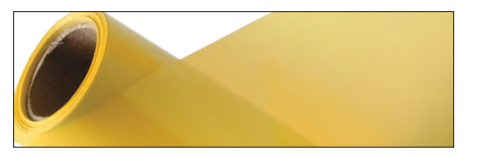

**IRIDESCENT, FLUORESCENT IFR** Price  
 36" Roll 98.00

Available in Colors shown on the left.

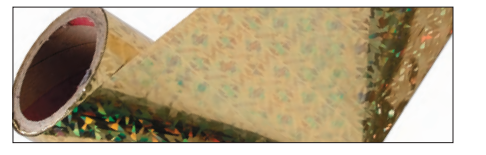

**DIFFRACTION IFR** Price  
 36" Roll 152.00

Available in Colors shown on the left.

- Fabrics
- Masking
- Custom Stage Curtains & Backdrops
- Custom Special Event Sewing
- Digital Printing
- LED Star Drops
- Pipe & Base
- Rentals
- Projection Materials
- Flooring
- Curtain Track
- Stage Equipment, FXs & Mirrors
- DMX Winches
- Scenery Props
- Shop & Production Supplies
- Tape
- Film & Video Supplies
- Index



## Designer Rain Curtains

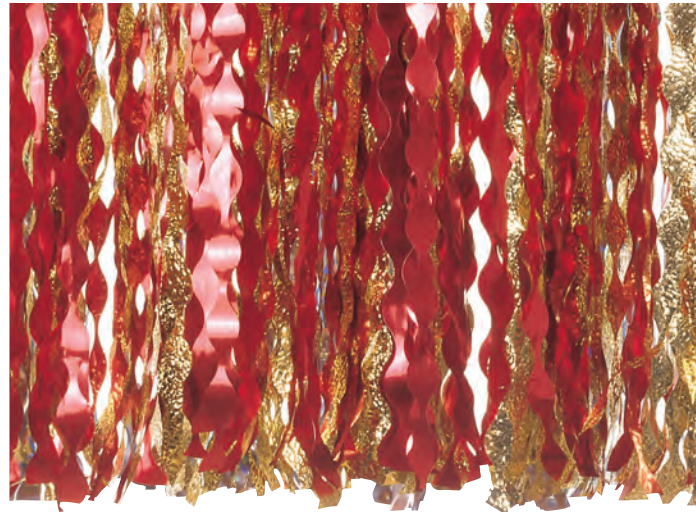

### SPANGLE CURTAIN

**Inherently Flame Retardant.** A variation on the traditional Rain Curtain; available in the same colors. A scallop cut, at the widest point approx. 3/4". Recommended 2 or 3 layers. See page 177 for colors.

2-Layer Curtain	Price Per Sq. Ft.
Metallic	2.20
Cracked Ice	2.80
Semi-Gloss	2.20
Iridescent, Fluorescent	3.10

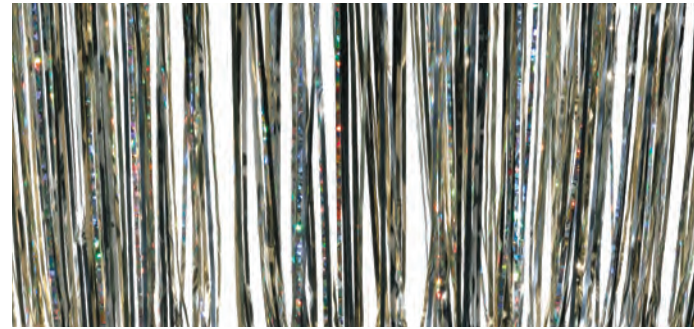

### ROSCO SLIT DRAPE

**Inherently Flame Retardant.** Pre-fabricated vinyl. 36" Wide Panels.

**Black/Silver, Black/Gold, Black, White or Silver Diffraction, Silver/Gold Diffraction, Silver/Iridescent/Gold, Iridescent**

	Price
8' <b>IFR</b>	17.85
16' <b>IFR</b>	38.35
24' <b>IFR</b>	81.40

**Black, Silver, Gold**

	Price
8' <b>IFR</b>	14.70
16' <b>IFR</b>	31.50
24' <b>IFR</b>	62.75



July 4th

### DESIGNER RAIN CURTAINS

**Inherently Flame Retardant.** Pre-designed Rain Curtains in Holiday, Special Occasion, and Theatrical Themes. All rain curtains are made with 3 layers and 3/4" cuts. Ties are not included. For ties at the top, add \$2.50 per foot of width. "Mardi Gras" and "July 4th" - bands of color are 6" wide.

Name	Color Combinations	Price Per Sq. Ft.
July 4th	Red Metallic, White Semi-Gloss, Blue Metallic	1.75
Chicago	Gold Metallic, Silver Cracked Ice, Gold Metallic	1.95
Waterfall	Iris Cracked Ice, Teal, Ice Blue	1.95
New Year's	Iris Cracked Ice, Pearl, Cerise	2.10
Mardi Gras	Gold Metallic, Green Metallic, Purple Metallic	1.75
Fiesta	Gold Cracked Ice, Red Cracked Ice, Gold Metallic	2.10



Chicago

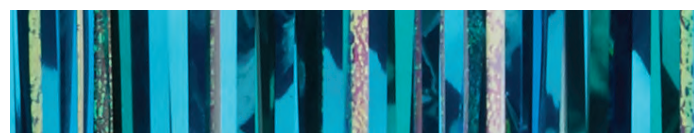

Waterfall



New Year's

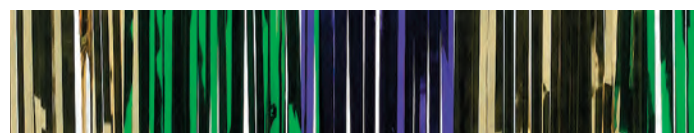

Mardi Gras



Fiesta

## Designer Rain Curtains



Product: Rain Curtain; Gatsby Party, World Trade Center Boston; Designer: Terry Mulryni Toomey; Scene Shop: Future Affairs Productions  
Photo: Rocky Toomey



Product: Rain Curtain; Oscars Themed Event, Keswick Hall - Virginia; Designer: The AV Company



Product: Floral Flash; Display Window at Bergdorf Goodman, NYC; Designer: David Hoey; Photo: Maureen Mulhern

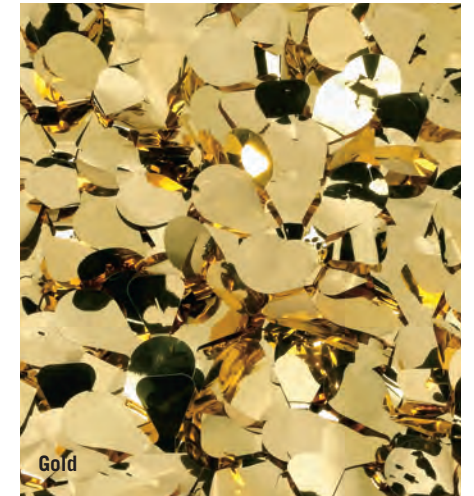

Gold



Snow



White



Silver



Red



Cerise

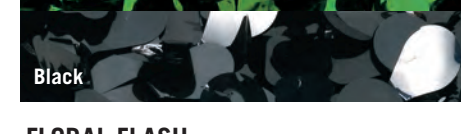

Purple



Blue

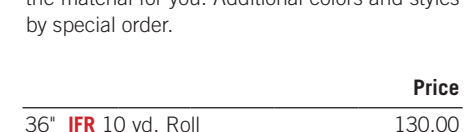

Green



Black

### FLORAL FLASH

**Inherently Flame Retardant.** This dazzling floral shaped vinyl creates a magical setting. If you want your design to shimmer like an ice sculpture or sparkle like a parade float, this is the material for you. Additional colors and styles by special order.

	Price
36" <b>IFR</b> 10 yd. Roll	130.00



# Stretch Shapes

**FOR UNIQUE  
PROJECTION  
SURFACES,  
PRINTABLE  
SIGNAGE & DECOR**

Stretch Shapes add color, dimension, interest and light to any event, display or stage production. They can be front or back lit and are great projection surfaces. They can also be digitally printed.

Go to [RoseBrand.com](http://RoseBrand.com) for more Stretch Shapes.

## Splats

**Inherently Flame Retardant.** 2-D Splats come in 3, 4, 5 and 6 point stretch shapes and are washable. Stretch Shapes in White (our most popular color) are now made with Boost (our premium 4-way Stretch Fabric). Boost is also available in Grey, Black and Red. All other colors will be made with Tendo. Sparkle and Crackle Tendo are also available. If you have existing Stretch Shape sets made with Tendo that you want to match, please specify Tendo.

### 3 POINT SPLAT

3.1 Splat	Size	Price
	5' x 5'	100.00
	8' x 8'	165.00
	10' x 10'	195.00
	12' x 12'	250.00
	15' x 15'	430.00
	20' x 20'	500.00

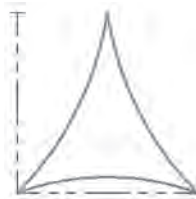

3.2 Splat	Size	Price
	5' x 8'	135.00
	6' x 10'	150.00
	8' x 12'	195.00
	10' x 15'	240.00
	12' x 18'	400.00
	15' x 20'	465.00

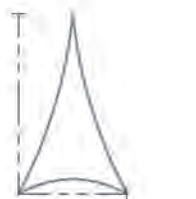

3.3 Splat	Size	Price
	5' x 5'	100.00
	8' x 8'	165.00
	10' x 10'	195.00
	12' x 12'	250.00
	15' x 15'	430.00
	20' x 20'	500.00

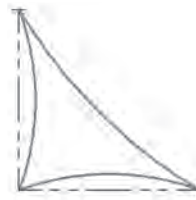

### 4 POINT SPLAT

4.1 Splat	Size	Price
	5' x 5'	115.00
	8' x 8'	180.00
	10' x 10'	210.00
	12' x 12'	275.00
	15' x 15'	460.00
	20' x 20'	550.00

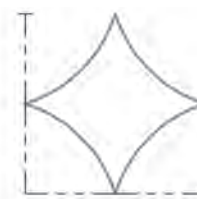

4.2 Splat	Size	Price
	5' x 8'	160.00
	6' x 10'	220.00
	8' x 12'	270.00
	10' x 15'	335.00
	12' x 18'	485.00
	15' x 20'	585.00



4.3 Splat	Size	Price
	5' x 8'	160.00
	6' x 10'	220.00
	8' x 12'	270.00
	10' x 15'	335.00
	12' x 18'	485.00
	15' x 20'	585.00



4.4 Splat	Size	Price
	5' x 5'	120.00
	8' x 8'	185.00
	10' x 10'	215.00
	12' x 12'	280.00
	15' x 15'	465.00
	20' x 20'	555.00

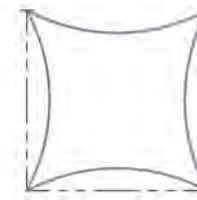

**DIMENSIONS**  
All dimensions are the stretched dimensions. Sizes are listed as **Width X Height**. Actual sizes and shapes may vary slightly due to the nature of stretch fabrics.

**FINISHES**  
Standard construction is with merrowed/serged edges and fabric loops for attachment. Color Edging is available for an additional \$25.

**Sizes with two dimensions larger than 10' will be seamed.**

## Splats

### IFR BOOST - STRETCH SHAPE COLORS

**IFR Boost**, Rose Brand's breakthrough heavy weight stretch fabric with the most 4-way stretch possible in a Flame Retardant fabric.

#### BOOST COLORS

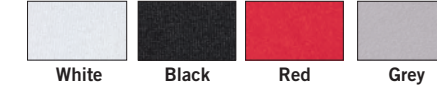

### IFR TENDO - STRETCH SHAPE COLORS

**IFR Tendo**, Rose Brand's Trevira® IFR stretch fabric.

#### TENDO COLORS

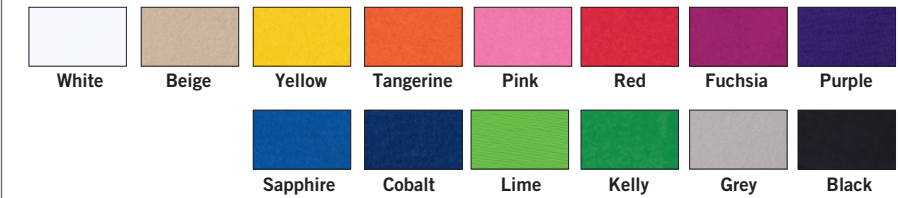

#### SPARKLE TENDO COLORS



#### CRACKLE TENDO COLORS



Please call or email for pricing on Sparkle and Crackle Tendo colors.

### 5 POINT SPLAT

5.1 Splat	Size	Price
	5' x 5'	140.00
	8' x 8'	210.00
	10' x 10'	275.00
	12' x 12'	350.00
	15' x 15'	560.00
	20' x 20'	645.00

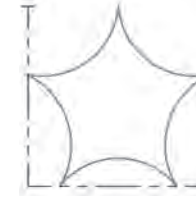

5.2 Splat	Size	Price
	5' x 8'	170.00
	6' x 10'	220.00
	8' x 12'	270.00
	10' x 15'	335.00
	12' x 18'	485.00



### 6 POINT SPLAT

6.1 Splat	Size	Price
	5' x 5'	150.00
	8' x 8'	225.00
	10' x 10'	290.00
	12' x 12'	365.00
	15' x 15'	585.00
	20' x 20'	675.00

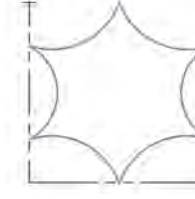

6.2 Splat	Size	Price
	5' x 8'	180.00
	6' x 10'	235.00
	8' x 12'	285.00
	10' x 15'	355.00
	12' x 18'	510.00
	15' x 20'	610.00

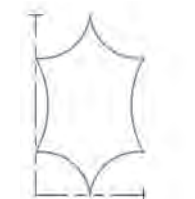



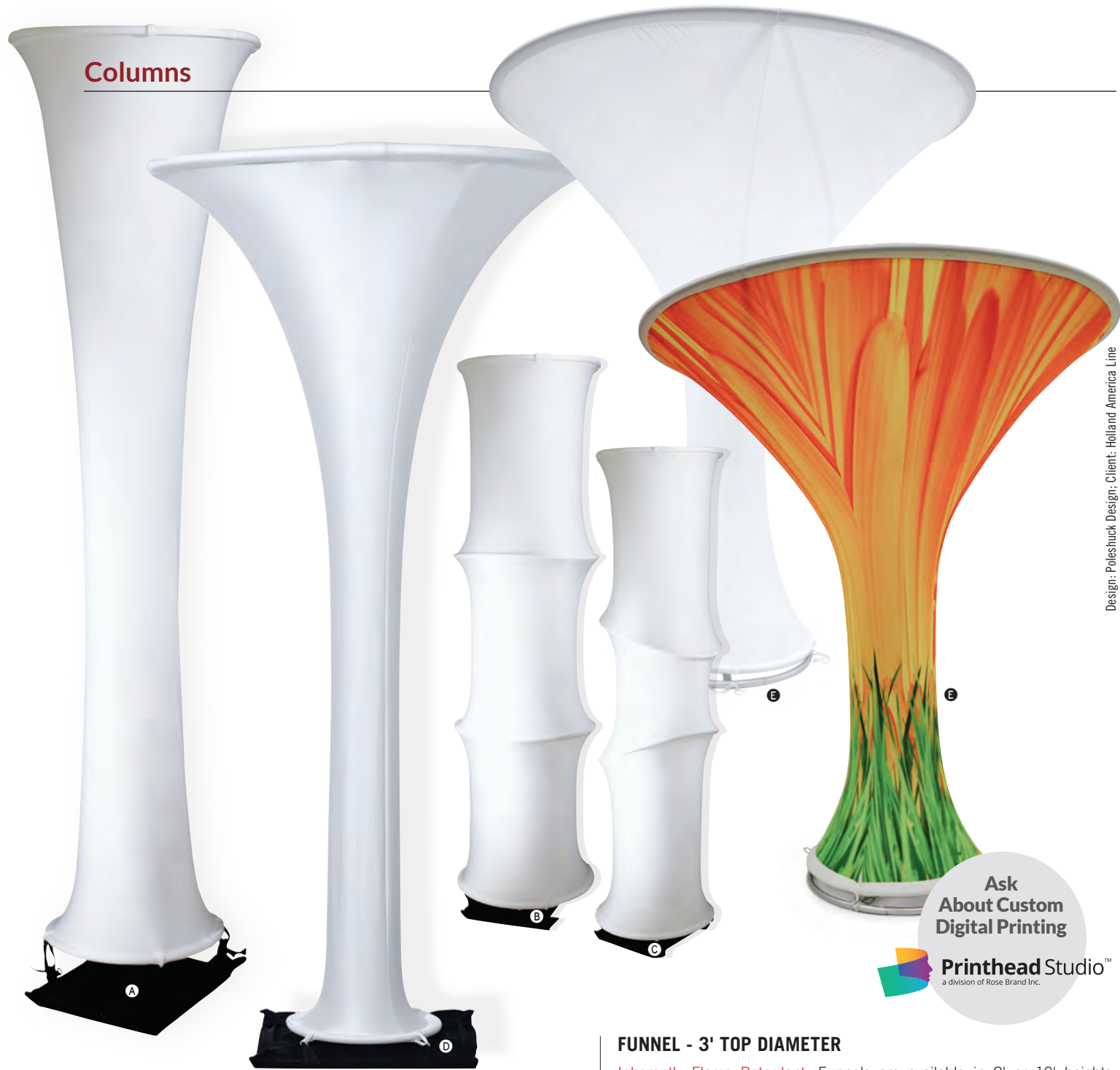

**Columns**

**HOOP COLUMNS**

**Inherently Flame Retardant.** Hoop Columns are available in 24" or 36" top diameter. Built with our custom constructed hub at the top and fabric loops at the bottom, they can be suspended from above or used with Rose Brand Pipe & Base. Collapsible for compact UPS/FedEx Shipping.

Available in **IFR** Boost or **IFR** Tendo for Colors, Sparkle, and Crackle. See page 181.

24" Top Diameter Tendo Hoop	8' H	12' H	15' H	20' H
<b>A</b> 18" Bottom Diameter	230.00	305.00	355.00	420.00
<b>B</b> 24" Bottom Diameter	265.00	350.00	410.00	460.00
36" Top Diameter Tendo Hoop	8' H	12' H	15' H	20' H
<b>A</b> 27" Bottom Diameter	250.00	330.00	380.00	450.00
<b>B</b> 36" Bottom Diameter	285.00	400.00	440.00	520.00

**FUNNEL - 3' TOP DIAMETER**

**Inherently Flame Retardant.** Funnels are available in 8' or 12' heights. 8' Funnel has a top diameter of 36" and a bottom diameter of 20". 12' Funnel has a top diameter of 36" and a bottom of 24".

Available in **IFR** Boost or **IFR** Tendo for Colors, Sparkle, and Crackle. See page 181.

Tendo Funnel	8'	12'
<b>D</b>	250.00	330.00

**FUNNEL - 8' TOP DIAMETER**

**Inherently Flame Retardant.** Comes with its own stand. 30 lb. sandbag recommended for added stability. Funnels are available in 7', 8' or 9' heights. Top diameter is 8' and bottom diameter is 3'. Fabric can be custom digitally printed at additional cost.

Free Standing Funnel	7' 8' 9'
<b>E</b>	1,400.00

Ask About Custom Digital Printing  
  
 Printhead Studio™  
 a division of Rose Brand Inc.

Design: Poleshuck Design; Client: Holland America Line

**Stretch Walls**

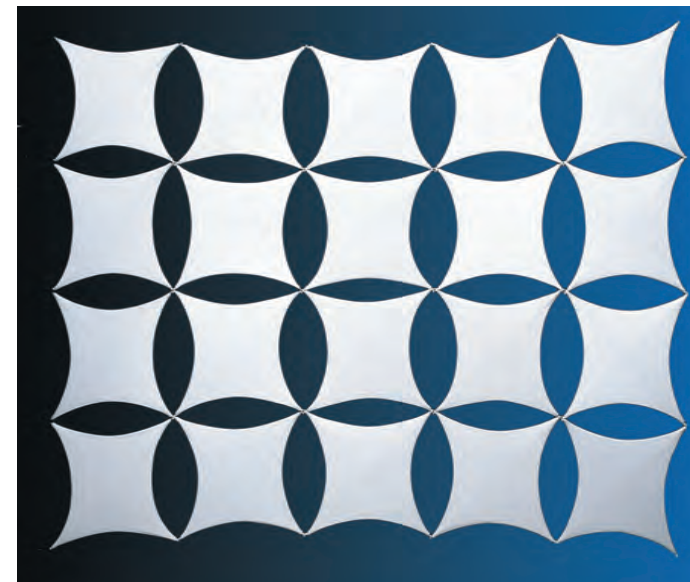

**QUATTRO TILE SERIES**

**Inherently Flame Retardant.** Mix & match these 2-D and 3-D Quattro tiles to create unique backdrops and ceiling treatments. The tensioned tiles create positive and negative space.

All corners join easily with the provided clips. These lightweight fabric forms are available in varying dimensions. For stability items **B** and **F** should only be used in a series with additional tiles.

Available in **IFR** Boost or **IFR** Tendo for Colors, Sparkle, and Crackle. See page 181.

Size	Price Per Tile
<b>2-Dimensional Tiles</b>	
<b>A</b> 2' x 2'	35.00
<b>B</b> 2' x 4'	70.00
<b>C</b> 4' x 4'*	90.00
<b>D</b> 4' x 6'*	135.00
<b>3-Dimensional Tiles - 12" Deep</b>	
<b>E</b> 2' x 2'	57.00
<b>F</b> 2' x 4'	125.00
<b>G</b> 4' x 4'*	145.00

\*Must ship common carrier.

**2-Dimensional Tiles**

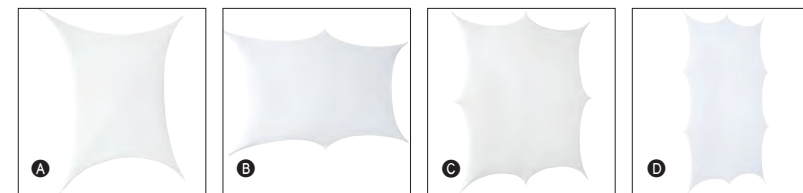

**3-Dimensional Tiles**

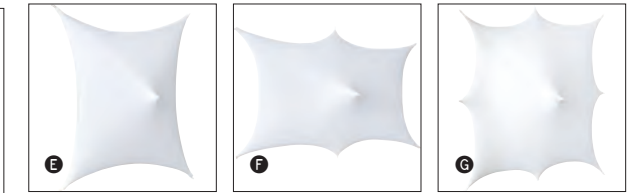

**CIRCLE WALL**

**Inherently Flame Retardant.** This stretch shape architectural disk is constructed with loops at each compass point to allow multiple pieces to hang together as a negative and positive opening wall. Many lighting effects are possible to create an outstanding décor piece.

Available in **IFR** Boost or **IFR** Tendo for Colors, Sparkle, and Crackle. See page 181.

Size	Price Per Circle
2' Diameter	32.00

Go to  
 RoseBrand.com  
 for more  
 Stretch Shapes.

Fabrics  
 Black Masking  
 Custom Stage Curtains & Backdrops  
 Custom Special Event Sewing  
 Digital Printing  
 LED Star Drops  
 Pipe & Base  
 Rentals  
 Projection Materials  
 Flooring  
 Curtain Track  
 Stage Equipment, FXs & Mirrors  
 DMX Winches  
 Scenery Props  
 Shop & Production Supplies  
 Tape  
 Film & Video Supplies  
 Index



## Rectangles & Circles

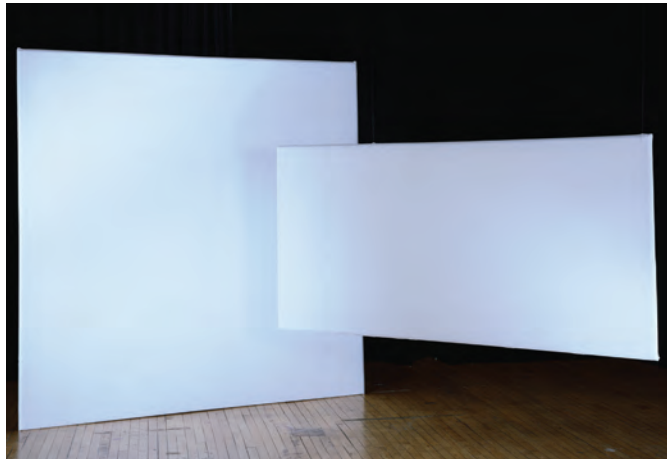

### RECTANGLES

**Inherently Flame Retardant.** Double sided, the zip-on pillowcase constructed of **IFR** White Boost or Tendo stretch fabric creates an excellent surface for lighting and projection. 2 pre-drilled holes on each side and 2 eye bolts for rigging are included.

Size	Price
4' x 8'	525.00
8' x 8'	675.00
8' x 10'	725.00

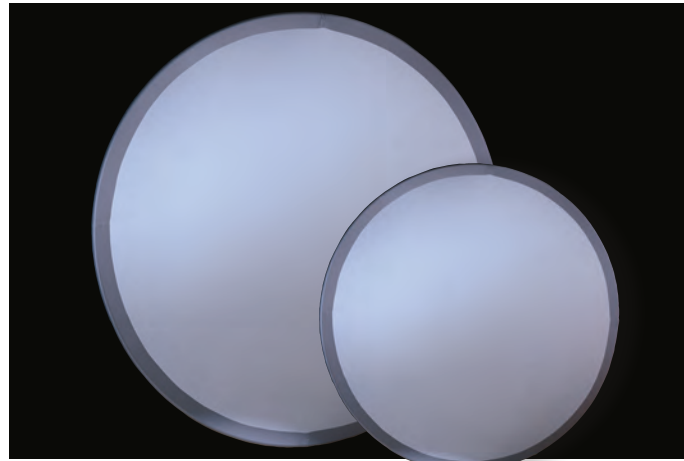

### CIRCLES

**Inherently Flame Retardant.** The Circle is constructed with **IFR** White Boost or Tendo stretch fabric banded in a choice of White, Silver or Black. The circular form creates a tailored geometric shape for front or rear projection and lighting. Multiple rigging points for flexible hanging options and the aluminum frame comes apart for UPS/FedEx shipping. See RoseBrand.com for rigging details.

Size	Price
4' Diameter	335.00
6' Diameter	495.00
8' Diameter	695.00
10' Diameter	795.00
12' Diameter (made with <b>FR</b> Poly Stretch)	950.00



Product: Spandex Stretch Circles; Lighting and Production Design: Pierre Marleau; Scene Shop: Orange Frog Productions, Inc.; Photo: Kelly Hofer

## Geometric Display Walls

### AVAILABLE IN 3 STYLES:

**WHITE IFR BOOST OR TENDO**  
Great for lighting and projection.

**WHITE IFR BOOST OR TENDO WITH LINING**  
Good for printing on both sides.

**DIGITALLY PRINTED**  
Perfect for events, tradeshow and visual merchandising. see Printhead Studio for digital prints for your next event



Ask About  
Custom Digital  
Printing

### CURVED WALL

HEIGHT	WIDTH	LINEAR LENGTH	DEPTH	PRICING		
				WHITE IFR BOOST	WITH LINER	DIGITALLY PRINTED
6'	8'	120"	30"	1,081.50	1,265.25	Call
8'	8'	120"	30"	1,165.50	1,349.25	Call
10'	8'	120"	30"	1,239.00	1,501.50	Call
6'	10'	140"	33"	1,260.00	1,470.00	Call
8'	10'	140"	33"	1,333.50	1,543.50	Call
10'	10'	140"	33"	1,417.50	1,732.50	Call
6'	12'	176"	42"	1,428.00	1,690.50	Call
8'	12'	176"	42"	1,512.00	1,774.50	Call
10'	12'	176"	42"	1,596.00	1,963.00	Call

### FLAT WALL

HEIGHT	WIDTH	GRAPHIC SIZE	PRICING		
			WHITE IFR BOOST	WITH LINER	DIGITALLY PRINTED
8'	8'	96" H x 96" W	1,030.00	1,205.00	Call
8'	10'	96" H x 111" W	1,120.00	1,320.00	Call

### WAVE WALL

HEIGHT	WIDTH	LINEAR LENGTH	DEPTH	PRICING		
				WHITE IFR BOOST	WITH LINER	DIGITALLY PRINTED
6'	8'	117"	17"	1,081.50	1,265.25	Call
8'	8'	117"	17"	1,165.50	1,349.25	Call
10'	8'	117"	17"	1,239.00	1,501.50	Call
6'	10'	140"	18"	1,260.00	1,470.00	Call
8'	10'	140"	18"	1,333.50	1,543.50	Call
10'	10'	140"	18"	1,428.00	1,732.50	Call
6'	12'	155"	20"	1,428.00	1,690.50	Call
8'	12'	155"	20"	1,512.00	1,774.50	Call
10'	12'	155"	20"	1,596.00	1,963.50	Call

Extremely easy set up. Double sided zip on pillowcase constructed cover slides on over the lightweight, portable and sturdy frames that are constructed from 1 ¼" diameter clear anodized aluminum tubing with satin finish. Use at your next corporate event or trade show exhibit. Travel bag included.

All three shapes can be used together. Connect multiple pieces together for dynamic designs. Graphics are available 1 sided and 2 sided. Also great as a projection surface.





# Winter Series

Go to [RoseBrand.com](http://RoseBrand.com) for more Stretch Shapes.

## THE BLIZZARD SERIES

It's a winter wonderland! These lightweight, white snowflakes designed exclusively for Rose Brand by Lionfish Design, create an instant holiday atmosphere in any space. Plastic tipped fiberglass spokes fit together easily inside the fabric. Multiple hanging points allow snowflakes to be hung individually or in groups.

Available in **IFR Boost** or **IFR Tendo** for Colors, Sparkle, and Crackle. See page 181.

2-Dimensional Snowflake	Price
3' Diameter	250.00
5' Diameter	295.00
7' Diameter	375.00

3-Dimensional Snowflake – Snowflakes are 18" deep	Price
3' Diameter	385.00
5' Diameter	450.00
7' Diameter	550.00

Giant 3D Flurry Snowflake – Snowflakes are 21" deep	Price
9'6" Diameter	795.00

Shown 3 dimensional; also available 2 dimensional. See [RoseBrand.com](http://RoseBrand.com).



3-D Frosty

3-D Flurry

3-D Sprinkle



### CLIKMAGNET

Great to hang Stretch Shapes. The Super KlikMagnet holds up to 10 lbs. Use with the MagPole and MagMover to attach to industrial ceilings and most drop ceiling T-bars.

	Price
Ⓐ Super KlikMagnet bag of 10	51.75
Ⓑ MagPole	147.00
Ⓒ Single MagMover	19.50

3-D Frosty shown in Sparkle Tendo (Silver/White)

# Truss, Pipe & Base Covers and Installation Accessories

Make your Hardware more presentable.



Tube Truss Cover

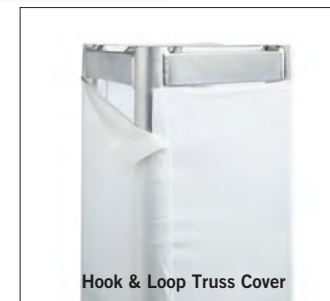

Hook & Loop Truss Cover



90 Degree 2 Way Corner Truss Cover



T Style 3 Way Corner Truss Cover



X Style 4 Way Corner Truss Cover



90 Degree Legdown 3 Way Corner Truss Cover

## TRUSS COVERS

**Inherently Flame Retardant.** **IFR** Boost or Tendo tube sewn for 12" or 20" Box Truss. Also available with Hook & Loop closures. Available in Black, Grey and White.

	Price Per Foot
12" Tube Truss Cover	8.00
20" Tube Truss Cover	12.00
12" Hook & Loop Truss Cover	11.00
20" Hook & Loop Truss Cover	15.00

12" Truss	Price Per Corner
90 Degree 2 Way Corner Truss Cover	150.00
T Style 3 Way Corner Truss Cover	150.00
X Style 4 Way Corner Truss Cover	150.00
90 Degree Legdown 3 Way Corner Truss Cover	150.00

20" Truss	Price Per Corner
90 Degree 2 Way Corner Truss Cover	172.50
T Style 3 Way Corner Truss Cover	172.50
X Style 4 Way Corner Truss Cover	172.50
90 Degree Legdown 3 Way Corner Truss Cover	172.50

## TULLE-TEX TRUSS COVERS

**Inherently Flame Retardant.** Industrial, semi-transparent surface. Lights beautifully! Colors page 75.

	Price Per Foot
12" Tube	12.00
20" Tube	18.00
12" Hook & Loop Closure	16.00
20" Hook & Loop Closure	21.00

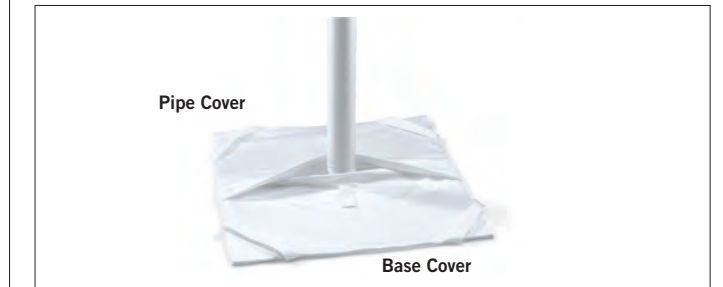

Pipe Cover

Base Cover

## PIPE & BASE COVERS

**Inherently Flame Retardant.** Mask Pipe & Base with **IFR** Boost. Pipe Covers are fabricated for 2" outside diameter pipe. Black or White.

	Price
Pipe Cover (6' minimum)	2.00/ft.
18" x 18" Base Cover	24.75
24" x 24" Base Cover	29.75



Base Cover

## ECONOMICAL BASE COVERS

**Inherently Flame Retardant.** Cheap and easy single layer base covers cut to size with a center pin hole. Grab some double stick tape and liven up your bases. 15 oz. Encore. Available in Black, Pewter and White.

	Price
19" x 19" Base Cover	8.50
25" x 25" Base Cover	10.00

## SEEMLESS TRUSS SOCKS NEW

Seamless circular knit truss cover sleeves slide over your 12" box truss quickly and easily. Overlock construction resists running if torn or snagged. Available in white and black, by the foot or in full 100 ft rolls.

	Cut	Full
White	7.50	5.95
Black	8.50	6.75





# Printhead Studio™

a division of Rose Brand Inc.

Printhead Studio Features .....190

Printhead Studio Advantages and Industry Experience.....192

Printhead Studio Products .....194

Printhead Studio Digital Prints.....196

Custom Printed Fabrics By The Yard .....198

## Up to 16 ft High Seamless, Gorgeous Printing on Soft Fabrics

New State-of-the-Art In-House Technology

Contact us:  
877-825-6620  
sales@printheadstudio.com  
www.printheadstudio.com



Product: Printed Scrim; Bar Design at Hard Rock Hotel Casino Atlantic City; Designer: Jeffrey Beers International LLC; Photo: Robert DeI Pazzo

- Fabrics
- Black Masking
- Custom Stage Curtains & Backdrops
- Custom Special Event Sewing
- Digital Printing
- LED Star Drops
- Pipe & Base
- Rentals
- Projection Materials
- Flooring
- Curtain Track
- Stage Equipment, FXs & Mirrors
- DMX Winches
- Scenery Props
- Shop & Production Supplies
- Tape
- Film & Video Supplies
- Index





**Printhead Studio™**  
a division of Rose Brand Inc.

- Astounding color reproduction using the most advanced technology
- Digitally printed backdrops on soft fabrics, seamless up to 16 ft high
- Graphics of all types including custom flooring, exterior prints, die cut vinyl, truck wraps & more.

**Vibrant Color**

Using the most advanced direct dye printing technology, we maintain stringent color accuracy and print a rich, wide color gamut.

**Why Soft Fabric?**

Our unique finishing process produces soft and supple drops. They fold for cost-effective shipping, and "hang out" for wrinkle-free installation.

**Super-Wide Format**

The Rhotex 500 is the newest class of super-wide direct dye platforms and produces gorgeous, seamless prints 16 ft high.

**Consultative Approach**

Our experts will take your vision and guide your project to successful completion – interior or exterior, large or small, typical or never-before-attempted.

**Expert Sewing & Fabrication**

We are the largest custom sewing and fabrication facility in North America, creating custom backdrops of any size and shape, even hundreds of feet long.

**Fast Turnaround**

We maintain maximum flexibility in production scheduling to meet your fastest delivery needs.

- Fabrics
- Black Masking
- Custom Stage Curtains & Backdrops
- Custom Special Event Sewing
- Digital Printing
- LED Star Drops
- Pipe & Base
- Rentals
- Projection Materials
- Flooring
- Curtain Track
- Stage Equipment, FXs & Mirrors
- DMX Winches
- Scenery Props
- Shop & Production Supplies
- Tape
- Film & Video Supplies
- Index



## Printhead Studio™ Advantages

We have decades of experience successfully meeting the needs of our customers, powered by the newest fabric printing technologies.

### Superior Color Reproduction on Truly Wide Width, Soft Fabrics

We use the most advanced direct dye digital printer on the market with an expanded color gamut to provide astounding color reproduction. Delivered via direct dispersion, our proprietary water based inks are infused into the fibers of the fabric instead of printed just on top of it. Your image stays vibrant over time, even after washing.

Soft fabrics offer huge advantages over the traditional stiff substrates used in UV or latex printing. Shipping fabric is cheaper and dramatically simplified since our prints can easily fold into a box for transport. Wrinkles quickly stretch or steam away during installation. There is no risk of cracking or creasing and no need for long, expensive shipping tubes.

### A Higher Level of Service

Our consultative approach makes your project easier to manage. Tell us your objectives and constraints and our expert project managers will guide you through the process, ensuring the success of both your printed image and your budget. Whether you need a simple banner or a complex 3-dimensional sculpture, our experienced fabrication teams have done it before, and done it fast.

Decades of theatrical and event production experience have taught us how to deliver exceptional quality within tight time constraints. We have the largest and most experienced sewing and finishing operation in the business with more than 100 stitchers working in 165,000 square feet.

Trust us for expert counsel, accurate color reproduction and finished pieces that will last.

## Printhead Studio™ Industry Experience



**THEATRE**



**FILM & TV**



**TRADE SHOWS**



**ARENAS**

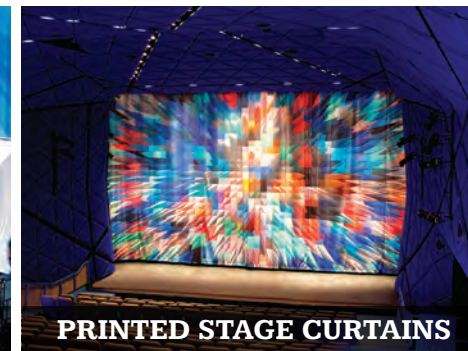

**PRINTED STAGE CURTAINS**



**ARCHITECTURAL ELEMENTS**



**SPECIAL EVENT VENUES**



**RETAIL**

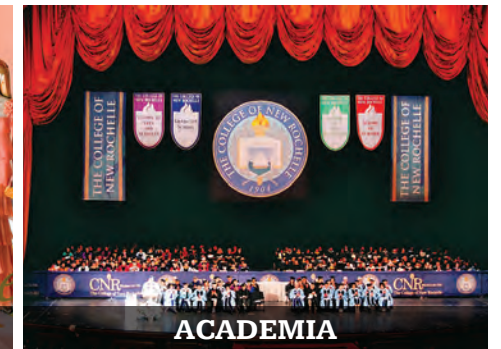

**ACADEMIA**



**PRINTED STUDIO FLOORING**

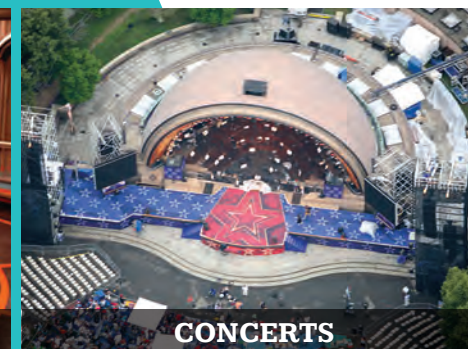

**CONCERTS**



**CORPORATE EVENTS**



**HOUSES OF WORSHIP**



**CRUISE SHIPS**



**RETAIL WALL FABRIC**

Product: Printed Impact Floor, 6 oz. Printed Poplin; NBC Sports Pyeong Chang 2018 Winter Olympics, Venue: International Broadcast Center, Pyeong Chang, South Korea; Designer: Bryan Higgason, HD Studio; Scene Shop: blackwalnut; Photo: Jacob Gendelman

- Fabrics
- Black Masking
- Custom Stage Curtains & Backdrops
- Custom Special Event Sewing
- Digital Printing
- LED Star Drops
- Pipe & Base
- Rentals
- Projection Materials
- Flooring
- Curtain Track
- Stage Equipment, FXs & Mirrors
- DMX Winches
- Scenery Props
- Shop & Production Supplies
- Tape
- Film & Video Supplies
- Index



## Printhead Studio™ Products

We provide amazing color reproduction on soft seamless fabric up to 16' high, as well as on flooring and vinyl. Some of the digitally printed products that we produce on a regular basis include:

### Fabric Prints

Scenic backdrops  
Stretch fabrics  
Back lit images  
Kabuki drops

### Exterior Prints

Banners  
Flags  
Vinyl Mesh  
Truck Wraps

### Printed Flooring

Impact!™  
Vinyl Flooring  
Compression Tiles  
Ground Cloths

### Custom Fabrication

Custom Sewing  
Rigging & Mechanics  
Shapes & Forms  
Scenery and Exhibits

### SEG Framing (Silicon Edge Graphics)

Custom dimensions  
For back or front lighting  
Free-standing or wall-mounted

\*Impact!™ floor is a 10ft wide, rear printed, clear floor ready for the most demanding environments. Crisp, vibrant color shows through the clear substrate and is completely protected from foot traffic, scrapes and scuffs.

Printed Fabrics by  
The Yard  
see Pages 198-199

Ask about our  
Printed Fabric Samples.  
Call 877-825-6620



FABRIC PRINTS

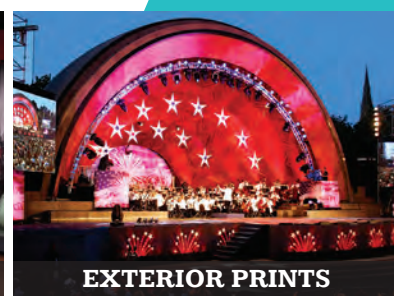

EXTERIOR PRINTS



PRINTED FLOORING



CUSTOM FABRICATION



SEG FRAMING

## Now offering turnkey SEG framing solutions!

We will size your new Printhead graphic panel to your existing SEG frame; Or we can provide a complete system of fabric and frame to meet the needs of your project.

Partnering with leading frame providers, we can offer:

- Low profile frames
- Surface mount
- Free standing
- Over sized
- Backlit
- and custom shapes and configurations



Product: Printed Poly Duck; Oregon Symphony: Rite of Spring; Arlene Schnitzer Concert Hall; Designer: Matthew Haber; Scene Shop: Infinite Scenic; Photo: Jacob Wade

We're happy to help you decide which fabric best meets your project needs.

Fabrics
Black Masking
Custom Stage Curtains & Backdrops
Custom Special Event Sewing
Digital Printing
LED Star Drops
Pipe & Base
Rentals
Projection Materials
Flooring
Curtain Track
Stage Equipment, FXs & Mirrors
DMX Winches
Scenery Props
Shop & Production Supplies
Tape
Film & Video Supplies
Index



## Digital Prints



Product: Digitally Printed Extra Wide Muslin; Steve-O: Guilty as Charged; The Nacelle Company; The Paramount Theater - Austin, TX; Produced by Comedy Dynamics for Showtime Director: Sam Brownfield; Production Designer: James Kronzer; Photo: The Nacelle Company



Product: 6 oz. Printed Poplin; BCBG Show, Fashion Week; Set designer: Anna Karlin; Producer: Shades of Grey



Product: Digitally printed on Mesh 30; Royal Caribbean Productions, Symphony of the Seas; Director: Loren Van Breuk Production Designers: Gerry Hariton & Vicki Baral; Costume Designer: Alejo Vietti; Lighting Designer: Rui Rita; Photo: Gerry Hariton

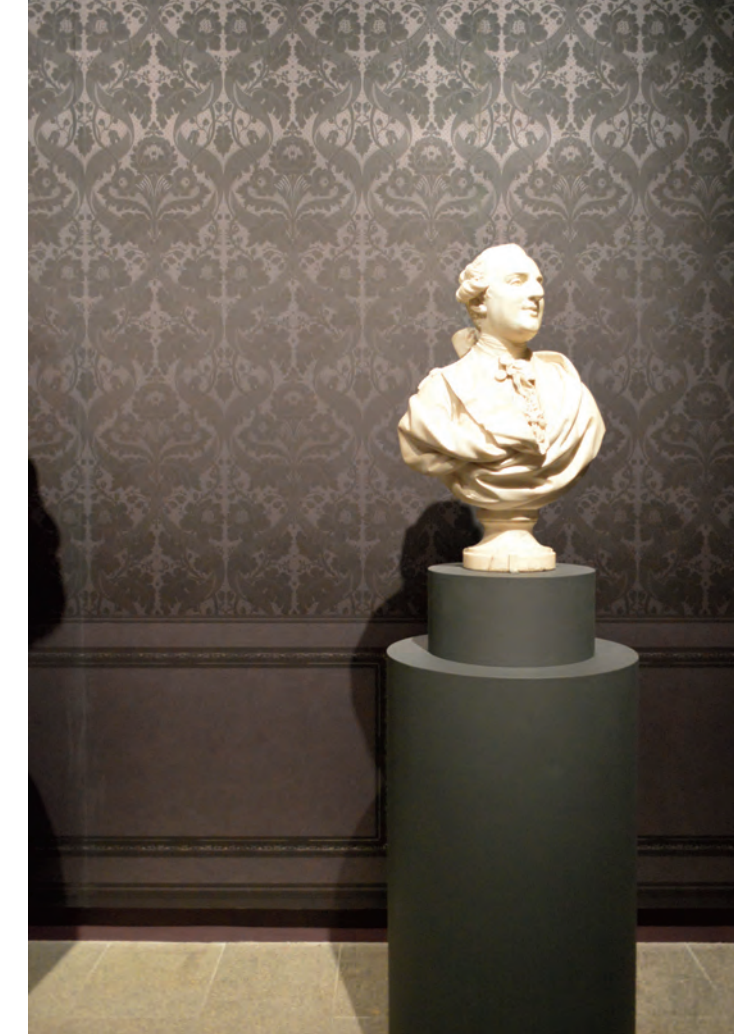

Product: Digitally Printed Wallpaper; Metropolitan Museum of Art; Visitors to Versailles at The MET Fifth Avenue; Photo: Louis Peter



Product: Digitally Printed Wallpaper; Metropolitan Museum of Art; Visitors to Versailles at The MET Fifth Avenue; Photo: Louis Peter

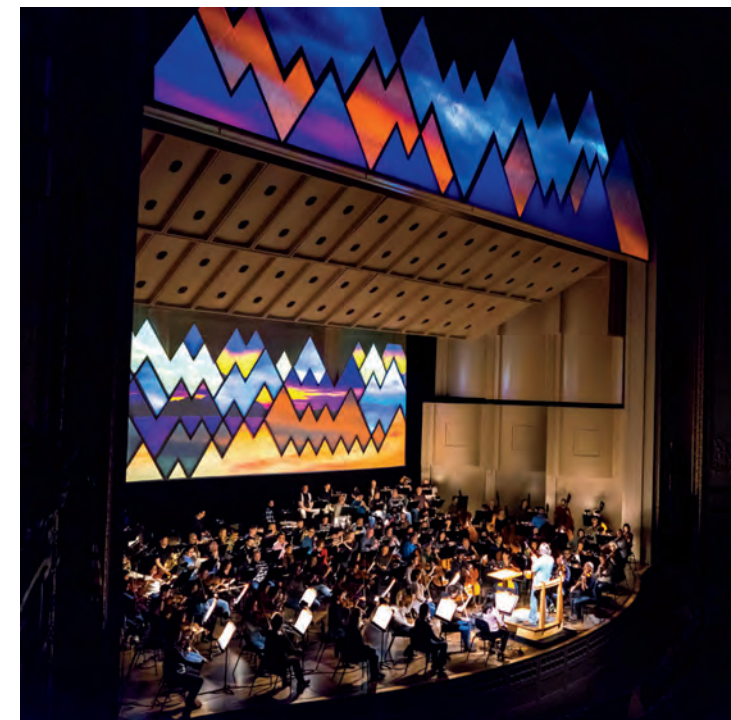

Product: Printed Poly Duck; Oregon Symphony: Rite of Spring; Arlene Schnitzer Concert Hall; Designer: Matthew Haber; Scene Shop: Infinite Scenic; Photo: Jacob Wade

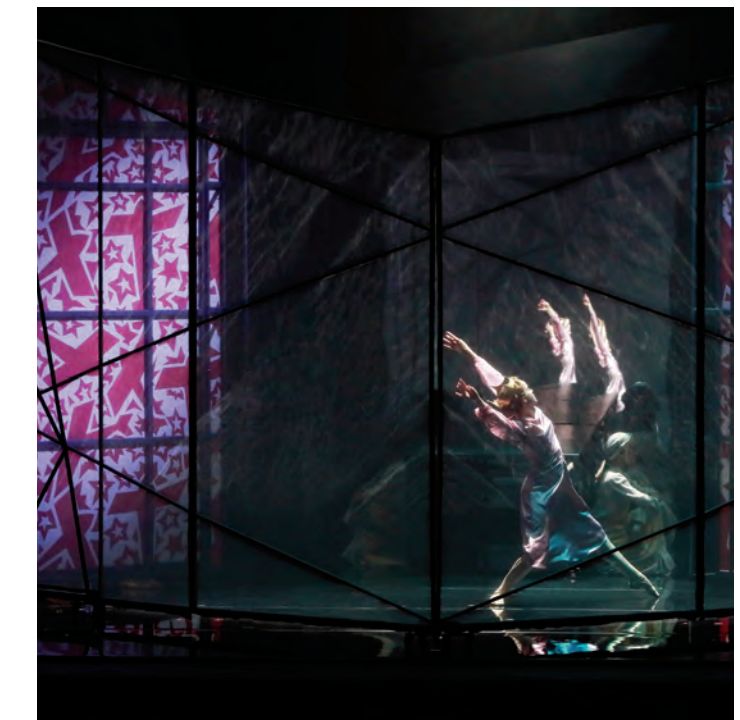

Product: Sharktooth Scrim, Digitally Printed Poly Duck Canvas; The Most Incredible Thing; Charlotte Ballet; Scene Shop: TheatreMarine Productions; Photo: Jeff Cravotta

Fabrics
Black Masking
Custom Stage Curtains & Backdrops
Custom Special Event Sewing
Digital Printing
LED Star Drops
Pipe & Base
Rentals
Projection Materials
Flooring
Curtain Track
Stage Equipment, FXs & Mirrors
DMX Winches
Scenery Props
Shop & Production Supplies
Tape
Film & Video Supplies
Index



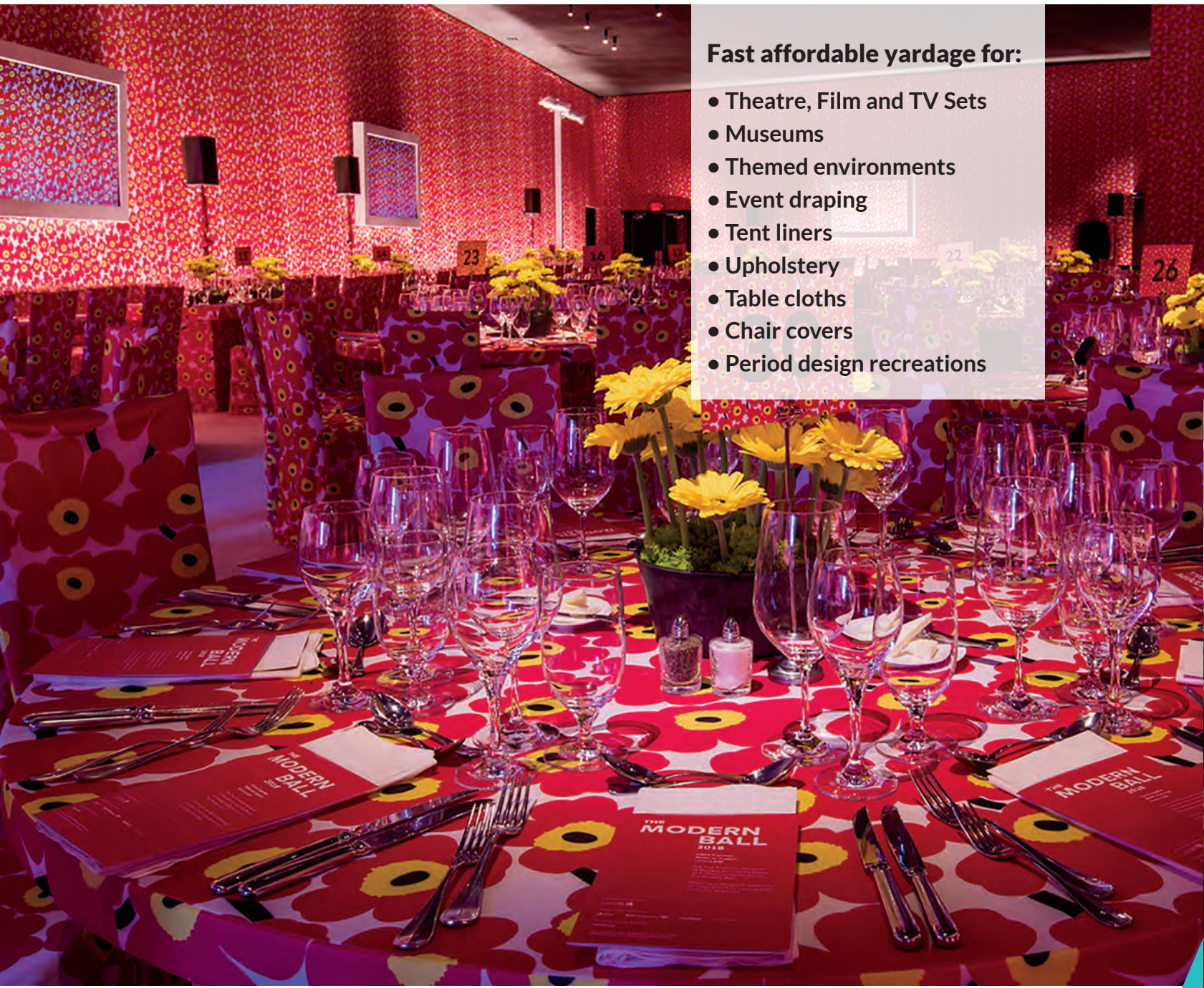

**Fast affordable yardage for:**

- Theatre, Film and TV Sets
- Museums
- Themed environments
- Event draping
- Tent liners
- Upholstery
- Table cloths
- Chair covers
- Period design recreations

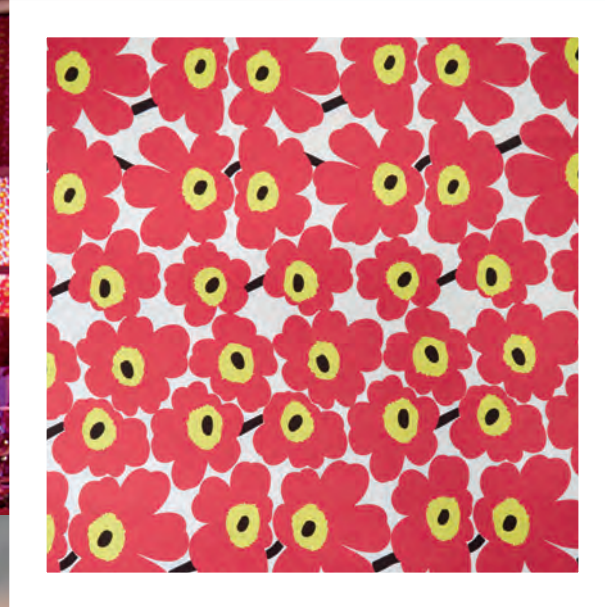

Beautiful custom repeat pattern printing on FR fabric is now available by the yard. A great solution for creating new fabric designs or recreating the look of classic period designs without the long lead times and expense of custom weaving.

The minimum is 100 yards and turnaround times can be as little as 2 weeks after the confirmation of print ready art work.

36" vertical repeats are standard and larger repeats are possible depending on the actual design.

Contact us for pricing as price per yard varies greatly with quantity.

**Available in a selection of fabrics in widths from 60" to 120"**

- Heavy Knit
- Poly Duck Canvas
- Poly Silk
- Stretch Knit
- Poly Sheer
- Flag Cloth
- Gaming Suede

Product: Custom digitally printed fabric; Event: San Francisco Museum of Modern Art (SFMOMA) 2018 Modern Ball; Designer: Stanlee R. Gatti Designs; Lighting: Got Light; Installation: Bright Event Rentals; Production: GB Event Productions; Photographer: Mekenna DeBack of Stanlee R. Gatti Designs

- Fabrics
- Black Masking
- Custom Stage Curtains & Backdrops
- Custom Special Event Sewing
- Digital Printing
- LED Star Drops
- Pipe & Base
- Rentals
- Projection Materials
- Flooring
- Curtain Track
- Stage Equipment, FXs & Mirrors
- DMX Winches
- Scenery Props
- Shop & Production Supplies
- Tape
- Film & Video Supplies
- Index



# Star Drops & LEDs

ShowLED Classic Star Drop .....202  
 ShowLED Chameleon Star Drop .....204  
 ShowLED Animation Curtains .....206



Product: ShowLED Classic; Andrea Bocelli, Madison Square Garden; Designer: David Korins; Photo: ©2015 Todd Kaplan

Fabrics
Black Masking
Custom Stage Curtains & Backdrops
Custom Special Event Sewing
Digital Printing
LED Star Drops
Pipe & Base
Rentals
Projection Materials
Flooring
Curtain Track
Stage Equipment, FXs & Mirrors
DMX Winches
Scenery Props
Shop & Production Supplies
Tape
Film & Video Supplies
Index



BUY OR RENT



Elegant white light or RGB colors. Numerous pre-programmed twinkling effects (or program your own). DMX compatible.

# SHOWLED

Make magic happen with ShowLED Star Drops. Create a classic night sky of twinkling stars or pulsing shifting shapes and loops. Working with ShowLED backdrops is fast and easy. ShowLED drops hang in a fraction of the time needed to rig heavy, modular LED walls. Simply pull the drop out of the road box or drapery bag, hang each section and connect the controllers. Each ShowLED drop is built to your specifications – size, color and type of fabric, color of LED and the density of the LED pixels attached. You get exactly the effect you need, at a price that fits your budget.

Classic Star Drop is composed of only Blue and White LEDs to create an elegant and classic star field.

### ShowLED Classic Star Drop Cool white stars

A field of blue and white LEDs create a twinkling star field effect even in high ambient light. Durable, light-weight, and versatile, the Classic Star Drop is valued for quality effects and fast set up. It comes with ConBox, a DMX compatible, 8-channel controller to adjust the intensity of each strand of LEDs. With a typical spacing on the LEDs, each Con-Box can control up to 125 sq yards of Classic, or 512 LEDs.

### ShowLED Mini Controller Mini controller

The ShowLED Mini Controller offers a simple control solution when more full featured options are not needed. The hand held remote and control box combination lets you access a variety of presets for both the ShowLED Classic and ShowLED Chameleon drapes. Each Mini Controller can control 96 LEDs and is good for basic chases, color washes, and twinkle patterns. For larger drapes, greater programming versatility, and the ability to control the LEDs via DMX, use the ShowLED CONBox Controller.



Price  
125.00

- Fabrics
- Black Masking
- Custom Stage Curtains & Backdrops
- Custom Special Event Sewing
- Digital Printing
- LED Star Drops
- Pipe & Base
- Rentals
- Projection Materials
- Flooring
- Curtain Track
- Stage Equipment, FXs & Mirrors
- DMX Winches
- Scenery Props
- Shop & Production Supplies
- Tape
- Film & Video Supplies
- Index



# ShowLED Chameleon Star Drops

BUY OR RENT

Products: ShowLED Chameleon, Chiffon; Scenic Design: Jack Morton/PDG; Scene Shop: Black Walnut; Photo: Raeford Dwyer, courtesy of Jack Morton/PDG



## ShowLED Chameleon Star Drop Colored twinkling star field

Using high intensity RGB LEDs, the Chameleon Star Drop gives you the flexibility to light your star field in colors of your own choosing. Create colored twinkling effects and chases in stand-alone mode or program specific color looks by adjusting the RGB values of each strand in the drop. With a typical spacing on the LEDs, each Con-Box can control up to 60 sq yards of Chameleon, or 256 LEDs.

SHOWLED

Fabrics
Black Masking
Custom Stage Curtains & Backdrops
Custom Special Event Sewing
Digital Printing
LED Star Drops
Pipe & Base
Rentals
Projection Materials
Flooring
Curtain Track
Stage Equipment, FXs & Mirrors
DMX Whitches
Scenery Props
Shop & Production Supplies
Tape
Film & Video Supplies
Index



# ShowLED Animation Curtains

BUY OR RENT

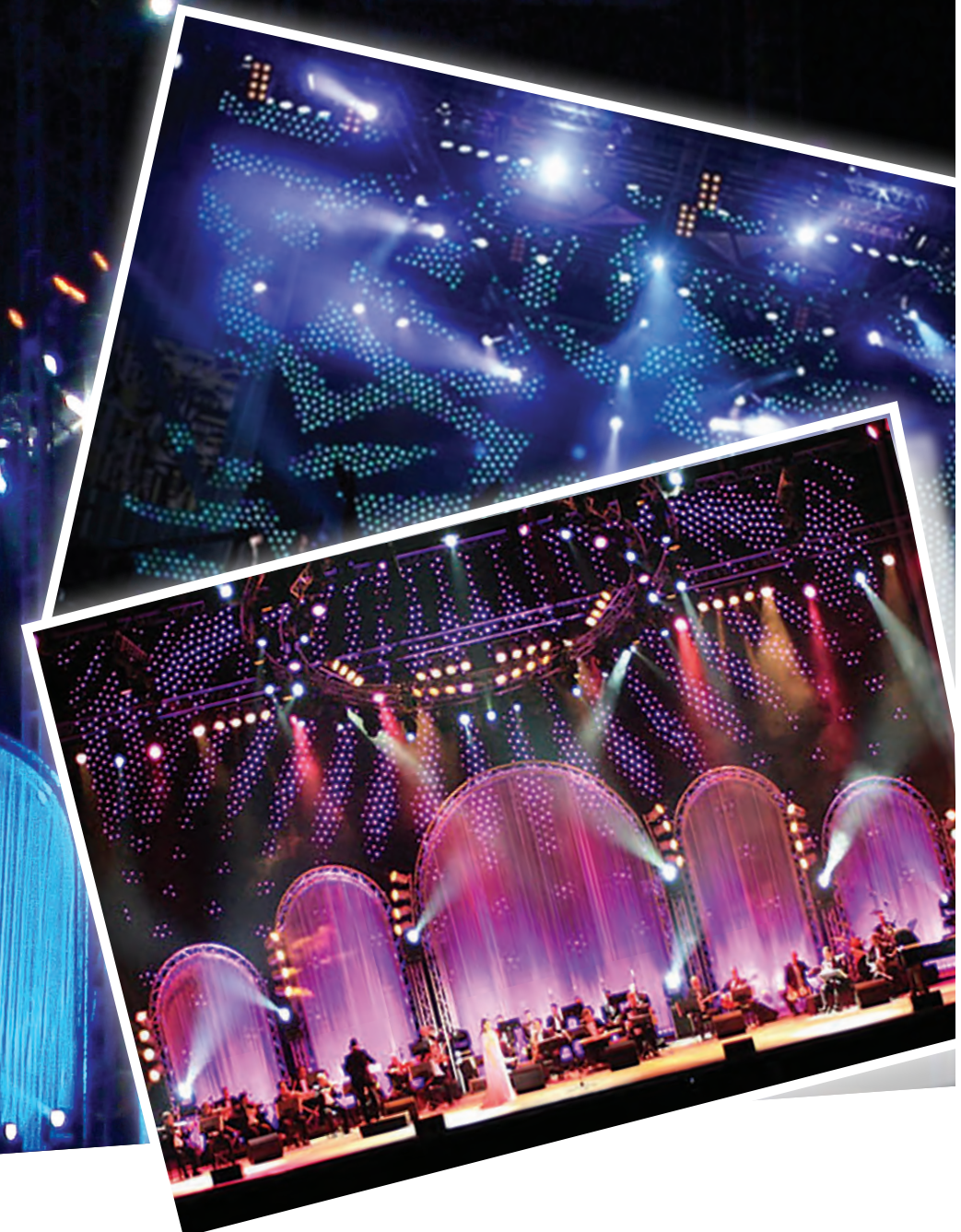

## SHOWLED

Add excitement, color and movement to any set design or event back drop using ShowLED Animation Curtain. Animation Curtain is a versatile low-resolution LED curtain with randomized pixel placement to eliminate any grids. Create dynamic and colorful motion graphics and simple imagery with control of individual RGB pixels.

► Go to Video at <http://bit.ly/rbanimationcurtain>

### ShowLED Animation Curtain Video driven low-res animation effects

Combine the simplicity of a drop with the limitless possibilities of pixel-level LED control and you have a ShowLED Animation Curtain. RGB pixels attached in a random pattern allow you to create impressive imagery and visual effects without the usual grid "ghosting" through. Animation Controllers can each drive 1024 RGB pixels and the V-Box Video Controller makes serving content seamless and easy.

### ShowLED Video Mesh Open netting for outdoor or underwater use

ShowLED Video Mesh is a 10mm x 10mm polyester netting with RGB LED pixels attached as on an Animation Curtain. When configured as Video Mesh, the RGB pixels are IP-X7, completely water-proof up to 30min. immersion – more than suitable for heavy rains both real and staged. The open mesh backing and weather proofing make Video Mesh suitable for outdoor environments, high wind areas, or where improved acoustical transparency is needed. ShowLED Video Mesh uses the same controllers and V-Box as Animation Curtains.



Fabrics
Black Masking
Custom Stage Curtains & Backdrops
Custom Special Event Sewing
Digital Printing
LED Star Drops
Pipe & Base
Rentals
Projection Materials
Flooring
Curtain Track
Stage Equipment, FXs & Mirrors
DMX Winches
Scenery Props
Shop & Production Supplies
Tape
Film & Video Supplies
Index



# Pipe & Base

- Pipe & Base 2.0 ..... 210
- Pipe & Base 2.0 Accessories ..... 214
- Pipe & Base 1.0 ..... 216
- Load In/Load Out Supplies..... 218
- Sand Bags ..... 219



Products: Beaded Swags, Voile, P&B 2.0 and Velour Rental Drapes; *Ella at 100: Forever the First Lady of Song*, Jazz at Lincoln Center's 2017 Annual Gala Concert; Rose Theater, Frederick P. Rose Hall; Designer: Zakaria Al-Alami; Photo: Frank Stewart

- Fabrics
- Black Masking
- Custom Stage Curtains & Backdrops
- Custom Special Event Sewing
- Digital Printing
- LED Star Drops
- Pipe & Base**
- Rentals
- Projection Materials
- Flooring
- Curtain Track
- Stage Equipment, FXs & Mirrors
- DMX Winches
- Scenery Props
- Shop & Production Supplies
- Tape
- Film & Video Supplies
- Index



# Pipe & Base 2.0

**BUY OR RENT**

**FOR QUICK AND EASY ROOM DECOR OR MASKING**



Products: Beaded Swags, Voile, P&B 2.0 and Velour Rental Drapes; *Ella at 100: Forever the First Lady of Song, Jazz at Lincoln Center's 2017 Annual Gala Concert*; Rose Theater, Frederick P. Rose Hall; Designer: Zakaria Al-Alami; Photo: Frank Stewart

## The New Industry Standard

Pipe & Base 2.0 replaces the hooks & torn slots in Pipe & Base 1.0, with smooth-ball end caps that plug into beautifully engineered crowns. Use for corporate events, private events, trade show booths, and more.

- Saves Time, Money, and Labor
- Drape supports can safely move 42 degrees down or 110 degrees up from their horizontal position under load.
- One person can set up pipe & base. No ladder needed in many cases.
- Virtually eliminate curtain tears and pipe damage.
- Precision tooled, adjustable and easy to set up.

► Go to Video at <http://bit.ly/pipebase2>



The smooth Ball End Caps eliminate curtain damage and make assembly easier.



Range of motion while under load.



No ladder needed in many cases.



One person set up.

Pipe & Base 2.0 Systems don't use nasty hooks and torn slots

Instead they use smooth Ball End Caps that plug into beautifully engineered Crowns.

## Buy Pipe & Base 2.0 Complete Systems

See Pages 212-213 to select parts for a complete system. Choose from different sizes of Adjustable Horizontal Drape Supports, Adjustable Telescoping Uprights and Bases.

## Retrofit Your Existing Stock of Pipe & Base with Pipe & Base 2.0 Components

Retrofit your existing drape supports and uprights with the new smooth-ball end caps and engineered crowns. You'll need 2 end caps for each drape support (a small and a large) and 1 crown for each upright. You can handle the retrofit yourself or we can do it for you for an additional charge.

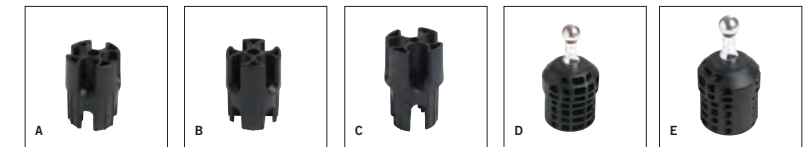

PIPE & BASE 2.0 RETROFIT & REPAIR COMPONENTS					
	ITEM/DESCRIPTION	ITEM NUMBER		USAGE	PRICE
A	<b>PIPE &amp; BASE 2.0 PIPE CROWN™</b> Fits Rose Brand Standard adjustable upright, providing a more smooth, flexible and secure join. The Crown replaces the slot in standard adjustable uprights. Has 1/4" - 20 threaded insert.	VERS0004	2 Stage	Retrofit your existing stock of standard pipe & base.	15.99
B		VERS0003	3 Stage		15.99
C	<b>PIPE &amp; BASE 2.0 DECO CROWN™</b> Fits Rose Brand Standard fixed 1.5" upright (special order), providing a more smooth, flexible and secure join. The Crown replaces the slot in standard adjustable uprights. No threaded insert.	VERS0029		Retrofit your existing stock of standard pipe & base	9.99
D	<b>PIPE &amp; BASE 2.0 BALL CAP™</b> Fits all Rose Brand Pipe & Base drape supports, providing a more smooth, flexible and secure join. Ball Caps should be riveted onto the ends of the drape supports, which then plug beautifully into the new Pipe & Base 2.0 Crown™. The Ball Caps™ replace the hooks in your crossbars (horizontal drape supports). Each support requires 1 large and 1 small.	VERS0002	Small	Retrofit your existing stock of standard pipe & base	10.99
E		VERS0001	Large		10.99

- Fabrics
- Black Masking
- Custom Stage Curtains & Backdrops
- Custom Special Event Sewing
- Digital Printing
- LED Star Drops
- Pipe & Base
- Rentals
- Projection Materials
- Flooring
- Curtain Track
- Stage Equipment, FXs & Mirrors
- DMX Winches
- Scenery Props
- Shop & Production Supplies
- Tape
- Film & Video Supplies
- Index





**Low Profile Bases for Pipe & Base 1.0 and Pipe & Base 2.0**

Zinc-plated steel for rust protection and long life. All base assemblies include the appropriate Slip-Fit Pin. Multiple pin holes allow for more than one upright to be used on a single base (back-to-back, side-to-side, or corner.) Minimum base sizes for specific heights are estimates. Some applications may require heavier bases. Base effectiveness (safety) will vary depending upon what is being supported, the length of the drape span, and use (i.e., high traffic areas or free-standing "goal posts" have greater likelihood of being tipped and should use heavier bases). The recommendations below are based upon the use of Banjo Cloth. When using velour, or in an area that may experience heavy air movement, consider heavier and/or wider bases.

**2.0 Adjustable Horizontal Drape Supports**

Comes with the smooth-ball end caps that enable easier and quicker setup and are less likely to tear your curtain vs standard hook and slot system. The drape support is comprised of telescoping, heavy-wall, high-strength, anodized aluminum tubing. The drape supports can be used at any length between fully collapsed and maximum stop length. Drapes and drape supports should always be mounted and removed while the uprights are vertical; never tip the structure up or down.

**2.0 Adjustable Uprights, 2 and 3 Piece Telescoping**

Comes with a beautifully engineered crown that enables easier and quicker setup vs Pipe & Base 1.0. Crown is made of fiber infused nylon for maximum wear resistance and shape retention. Upright is made of heavy duty, 2" diameter, anodized aluminum. Easy to use. No tools required for set-up or disassembly. Just slide upright over the Slip-Fit Pin on the base. Quickly adjusts to any height within the specific model range. The Slip-Lock Collar Assembly locks automatically when the inner pole is raised vertically to the desired height. The more pressure applied downward the tighter it will lock. To release the lock, simply raise the inner pole slightly and press up on the release ring. For SAFETY, hold the inner pole firmly while raising or lowering the height. **Note: The minimum height of adjustable uprights is equal to the lowest height of the pole PLUS the height of the Slip-Fit Pin.**

See Accessories on Page 214.

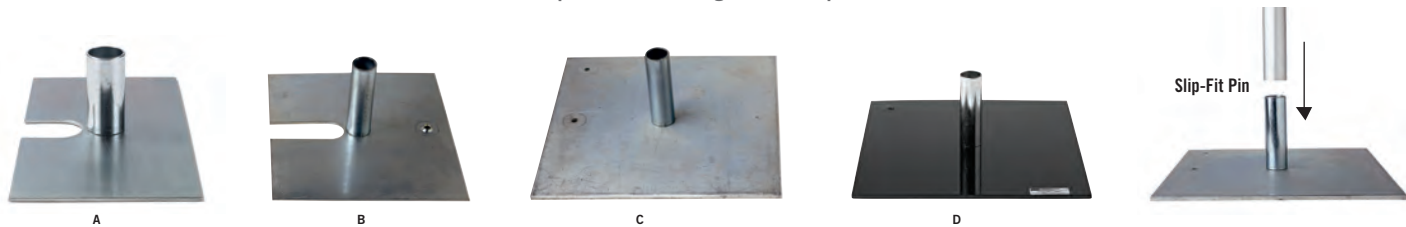

PIPE & BASE 1.0 AND PIPE & BASE 2.0 LOW PROFILE BASES									
	ITEM/DESCRIPTION	ITEM NUMBER	COLOR	SIZE	WEIGHT	STANDARD PIN LENGTH	PIN HOLES	MAX. HEIGHT <i>Manufacturer Recommended</i>	PRICE
<b>A</b>	LIGHT STANDARD	PBSB0017	Steel	8" x 14" x 3/16"	6 lbs	4"	2	3'	17.70
<b>B</b>	STANDARD	PBSB0018	Steel	14" x 16" x 3/16"	12 lbs	4"	2	8'	27.20
<b>C</b>	LIGHT HEAVY	PBSB0014	Steel	18" x 18" x 3/16"	17 1/2 lbs	4"	3	12'	53.80
	HEAVY	PBSB0012	Steel	18" x 18" x 3/8"	35 lbs	6"	3	16'	92.70
	LARGE LIGHT HEAVY	PBSB0016	Steel	24" x 24" x 3/16"	32 lbs	8"	3	20'	87.00
	LARGE HEAVY HEAVY	PBSB0015	Steel	24" x 24" x 3/8"	62 lbs	16"	3	24'	193.50
<b>D</b>	HEAVY-BLACK	PBSB0019	Black	18" x 18" x 3/8"	35 lbs	6"	3	16'	99.00



Slip-Lock Collar Assembly

F

PIPE & BASE 2.0 ADJUSTABLE HORIZONTAL DRAPE SUPPORTS							
	ITEM NUMBER	COLOR	RANGE	COLLAPSED	STOPS AT	PRIMARY USE	PRICE
<b>E</b>	VERS0005	Silver	2' to 3'	2'2"	3'	Narrow-width drapes	27.20
	VERS0006	Silver	3' to 5'	3'2"	5'	Narrow-width drapes	30.90
	VERS0007	Silver	4' to 7'	4'2"	6' and 7'	Narrow-width drapes	35.60
	VERS0008	Silver	5' to 8'	5'2"	8'	Narrow-width drapes	40.20
	VERS0009	Silver	6' to 10'	6'2"	8' and 10'	Boothing & backwalls	43.10
	VERS0010	Silver	7' to 12'	7'2"	10' and 12'	Boothing & backwalls	47.60
	VERS0011	Silver	8' to 14'	8'2"	10', 12' and 14'	Boothing & backwalls	52.10
	VERS0012	Silver	9' to 16'	9'2"	12', 14', and 16'	Banners & light-wt drapes	56.60
	VERS0032	Black	5' to 8'	5'2"	8'	Narrow-width drapes	68.12
	VERS0033	Black	7' to 12'	7'2"	10' and 12'	Boothing & backwalls	83.52
	VERS0034	Black	9' to 16'	9'2"	12', 14', and 16'	Banners & light-wt drapes	102.22

The list above is based upon the use of Banjo Cloth. If you are using a heavier fabric such as velour, you must build in a safety factor.

PIPE & BASE 2.0 ADJUSTABLE UPRIGHTS					
2 PIECE TELESCOPING					
	ITEM NUMBER	COLOR	SIZE	BASE SIZE	PRICE
<b>F</b>	VERS0013	Silver	3' to 5'	Minimum 14" x 16"	72.00
	VERS0014	Silver	5' to 8'	Minimum 14" x 16"	85.00
	VERS0015	Silver	7' to 12'	Minimum 8'H - 14" x 16", above 8'H - 18" x 18", 17 1/2 lbs	102.00
	VERS0016	Silver	9' to 16'	Minimum 18" x 18", 35 lbs	120.00
	VERS0018	Silver	11' to 20'	Above 16'H - 24" x 24", 62 lbs	134.00
	VERS0019	Silver	12' to 22'	Above 16'H - 24" x 24", 62 lbs	140.00
	VERS0035	Black	5' to 8'	Minimum 14" x 16"	113.80
	VERS0036	Black	7' to 12'	Minimum 8'H - 14" x 16", above 8'H - 18" x 18", 17 1/2 lbs	137.40
	VERS0037	Black	9' to 16'	Minimum 18" x 18", 35 lbs	159.90

Note: The minimum height of adjustable uprights is equal to the lowest height of the pole plus the height of the Slip-Fit Pin.

3 PIECE TELESCOPING					
	ITEM NUMBER	COLOR	BASE SIZE	SIZE	PRICE
	VERS0017	Silver	Recommended use with 62 lb bases.	9' to 23'	189.00

Note: The minimum height of adjustable uprights is equal to the lowest height of the pole plus the height of the Slip-Fit Pin.



Fabrics  
Black Masking  
Custom Stage Curtains & Backdrops  
Custom Special Event Sewing  
Digital Printing  
LED Star Drops  
Pipe & Base  
Rentals  
Projection Materials  
Flooring  
Curtain Track  
Stage Equipment, FXs & Mirrors  
DMX Winches  
Scenery Props  
Shop & Production Supplies  
Tape  
Film & Video Supplies  
Index



## Pipe & Base 2.0 Accessories

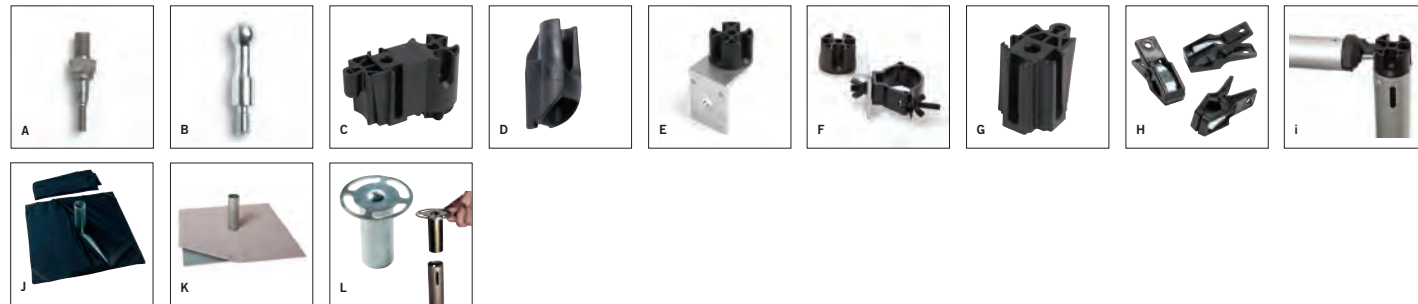

ACCESSORIES FOR PIPE & BASE 2.0 AND STANDARD PIPE & BASE 1.0						
ITEM	ITEM NUMBER	ITEM/DESCRIPTION	USAGE	PIPE & BASE 2.0	PIPE & BASE 1.0	PRICE
<b>A</b>	VERS0025	<b>PIPE &amp; BASE 2.0 THREADED MOUNTING POST™</b> The top of the Pipe & Base 2.0 Crown is threaded to enable the simple mounting of your LED light with our forged steel Threaded Mounting Post. Perimeter lighting has never been simpler! Fixture weight should not exceed 7 ½ lbs. Package of 6.	Easy Mounting of Lightweight Lighting Fixtures	X		139.99
<b>B</b>	VERS0024	<b>PIPE &amp; BASE 2.0 THREADED BALL STUD™</b> Use our Threaded Ball Stud to hang a projection screen. The stud fits standard screen frames with 9/16" thread inserts and the stud locks into the Pipe & Base 2.0 Crown. Package of ten.	Suspend a Frame Projection Screen Not to Exceed 7 ½' H x 13' W	X		59.99
<b>C</b>	VERS0028	<b>PIPE &amp; BASE 2.0 SIDEARM™</b> Each Sidearm provides additional slots to accommodate additional drape supports. Use multiple Sidearms for multiple drape supports. Only attach a Sidearm to a Crown, never to another Sidearm.	Build a Double or Triple Drape Line on a Single Upright	X		24.99
<b>D</b>	VERS0030	<b>PIPE &amp; BASE 2.0 SOCKET CLIP™</b> The Socket Clip fits into a standard slotted upright to enable the Ball Cap™ of a Pipe & Base 2.0 drape support to connect securely. Package of ten.	How To Use Your Old Slotted Uprights with new Pipe & Base 2.0 Drape Supports	X		33.99
<b>E</b>	VERS0026	<b>PIPE &amp; BASE 2.0 ANGLE MOUNTED CROWN™ – SWIVEL</b> The Angle Mounted Crown is designed to work with a clamp (clamps sold separately). It enables you to position the crown onto truss or virtually anything that a clamp can hang onto. Once the crown is clamped to a structure, place the Ball Cap™ of a Pipe & Base 2.0 drape support into the crown and you've now supported your drape without an upright. The Crown can swivel left and right - no threaded insert.	Set Up Curtains Without Using an Upright	X		29.99
<b>F</b>	VERS0042	<b>PIPE &amp; BASE 2.0 ANGLE MOUNTED CROWN™ – FIXED</b> Same functionality as E (above) except it does not swivel and it does come with a ¼-20 threaded insert.	Set Up Curtains Without Using an Upright	X		29.99
<b>G</b>	VERS0027	<b>PIPE &amp; BASE 2.0 SHOULDER MOUNT™</b> Its three ¼" flange nut rails and one ¼-20 threaded insert enable you to add hooks, signs, lightweight LED fixtures, eyelets, carabiner clips, etc. to your setup. Must be used in conjunction with Pipe & Base 2.0 crown.	Secure Lightweight Accessories to Pipe & Base 2.0 Uprights	X		19.99
<b>H</b>	PBDR0001	<b>DRAPE CLIPS</b> Plastic clips hold drapes together without pins. Bag of 100.	Clip Drapes Together - White	X	X	75.00
	PBDR0003		Clip Drapes Together - Black	X	X	75.00
<b>I</b>	VERS0048	<b>ANTI-ROLL CLIP ("BIRD BEAK")</b> Bag of 10.	Usually 1 per Support is Sufficient. Stops Tie on Drape from Rolling the Support	X		30.00
<b>J</b>	PBP00001	<b>PIPE &amp; BASE COVERS</b> Mask Pipe & Base with IFR Tendo. Pipe Covers are fabricated for 2" OD pipe (6' minimum).	Pipe Cover - Black	X	X	2.00/ft.
	PBP00002		Pipe Cover - White	X	X	2.00/ft.
	PBBA0001		18" x 18" Base Cover - Black	X	X	24.75
	PBBA0003		18" x 18" Base Cover - White	X	X	24.75
	PBBA0002		24" x 24" Base Cover - Black	X	X	29.75
	PBBA0004		24" x 24" Base Cover - White	X	X	29.75
<b>K</b>		<b>ECONOMICAL BASE COVERS</b> Cheap and easy single layer base covers cut to size with a center pin hole. Grab some double stick tape and liven up your bases. IFR 15 oz. Encore. Available in Black, Pewter and White.	19" x 19" Base Cover	X	X	8.50
			25" x 25" Base Cover	X	X	10.00
<b>L</b>	PBSP0022	<b>STANCHION TOP WITH PIN</b> Converts a 3' high standard (2" diameter) upright into a stanchion. Recommended minimum base size 14" x 16". Black or white plastic Stanchion Chain available. Call for pricing.	Converts Upright into a Stanchion		X	19.50

See Storage Materials on Page 218.

## Pipe & Base 2.0 Accessories

► Go to Video at <http://bit.ly/pipebase2>

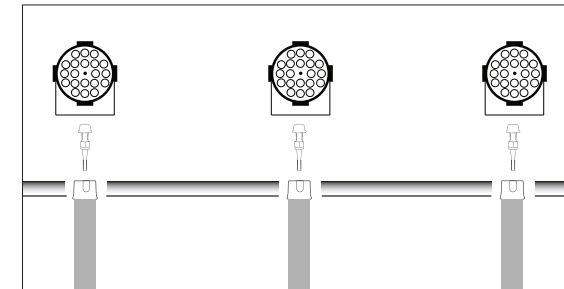

**A** Threaded Mounting Post used for easy Backlighting

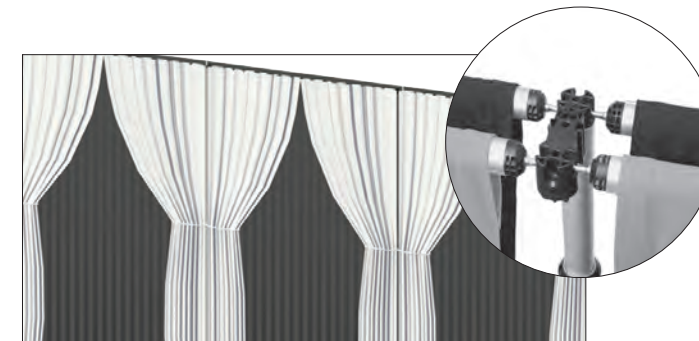

**C** One Sidearm connected to a single upright, creating a double drape line



**E** Set up curtains without using an Upright





See Accessories on Page 214.

**Low Profile Bases for Pipe & Base 1.0 and Pipe & Base 2.0**

Zinc-plated steel for rust protection and long life. All base assemblies include the appropriate Slip-Fit Pin. Multiple pin holes allow for more than one upright to be used on a single base (back-to-back, side-to-side, or corner.) Minimum base sizes for specific heights are estimates; some applications may require heavier bases. Base effectiveness (safety) will vary depending upon what is being supported, the length of the drape span, and use (i.e., high traffic areas or free-standing "goal posts" have greater likelihood of being tipped and should use heavier bases). The recommendations below are based upon the use of Banjo Cloth; when using velour, or in an area that may experience heavy air movement, consider heavier bases.

Powder coated in black, our Bases, Uprights and Telescoping Drape Supports are an elegant solution. These have exactly the same characteristics as our heavy duty 2" standard anodized aluminum pieces including ease of use and high strength. Extra care must be used when handling, as they are susceptible to scratching.

**1.0 Adjustable Horizontal Drape Supports**

Heavy-wall, high-strength, anodized aluminum tubing. Drape supports can be used at any length between fully collapsed and maximum stop length. Units with collapsed width of 5' or longer can extend approximately one foot past the maximum stop. Drapes and drape supports should always be mounted and removed while the uprights are vertical; never tip the structure up or down.

**1.0 Standard Uprights, Non-Telescoping**

Uprights are made of heavy duty 2" diameter anodized aluminum. Equipped with a set of 4 slots positioned every 90° 3/8" from the top. Uprights 6' and over have 2 sets of 4 slots (one set at 3' from the bottom and one set at the top).

**1.0 Adjustable Uprights, 2 & 3 Piece Telescoping**

Telescoping, heavy duty, 2" diameter, anodized aluminum. Easy to use; no tools required for set-up or disassembly. Just slide upright over the Slip-Fit Pin on the base. Quickly adjusts to any height within the specific model range. The Slip-Lock Collar Assembly locks automatically when the inner pole is raised vertically to the desired height. The more pressure applied downward, the tighter it will lock. To release the lock, simply raise the inner pole slightly and press up on the release ring. For SAFETY, hold the inner pole firmly while raising or lowering the height. **Note: The minimum height of adjustable uprights is equal to the lowest height of the pole plus the height of the Slip-Fit Pin.**

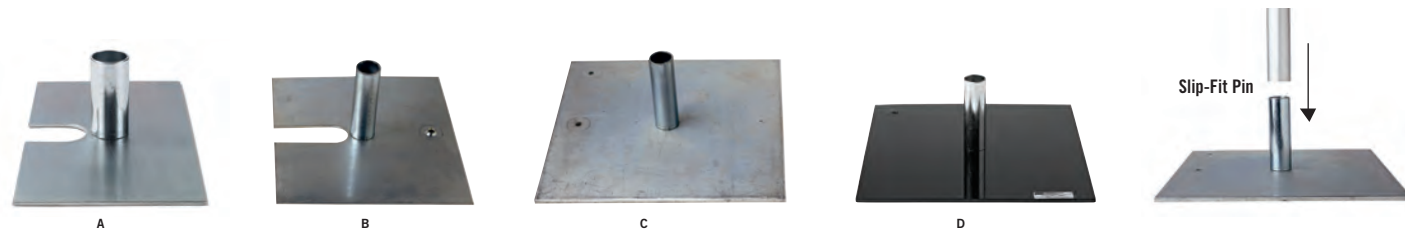

PIPE & BASE 1.0 AND PIPE & BASE 2.0 LOW PROFILE BASES									
	ITEM/DESCRIPTION	ITEM NUMBER	COLOR	SIZE	WEIGHT	STANDARD PIN LENGTH	PIN HOLES	MAX. HEIGHT <i>Manufacturer Recommended</i>	PRICE
<b>A</b>	LIGHT STANDARD	PBSB0017	Steel	8" x 14" x 3/16"	6 lbs	4"	2	3'	17.70
<b>B</b>	STANDARD	PBSB0018	Steel	14" x 16" x 3/16"	12 lbs	4"	2	8'	27.20
<b>C</b>	LIGHT HEAVY	PBSB0014	Steel	18" x 18" x 3/16"	17 1/2 lbs	4"	3	12'	53.80
	HEAVY	PBSB0012	Steel	18" x 18" x 3/8"	35 lbs	6"	3	16'	92.70
	LARGE LIGHT HEAVY	PBSB0016	Steel	24" x 24" x 3/16"	32 lbs	8"	3	20'	87.00
	LARGE HEAVY HEAVY	PBSB0015	Steel	24" x 24" x 3/8"	62 lbs	16"	3	24'	193.50
<b>D</b>	HEAVY-BLACK	PBSB0019	Black	18" x 18" x 3/8"	35 lbs	6"	3	16'	99.00

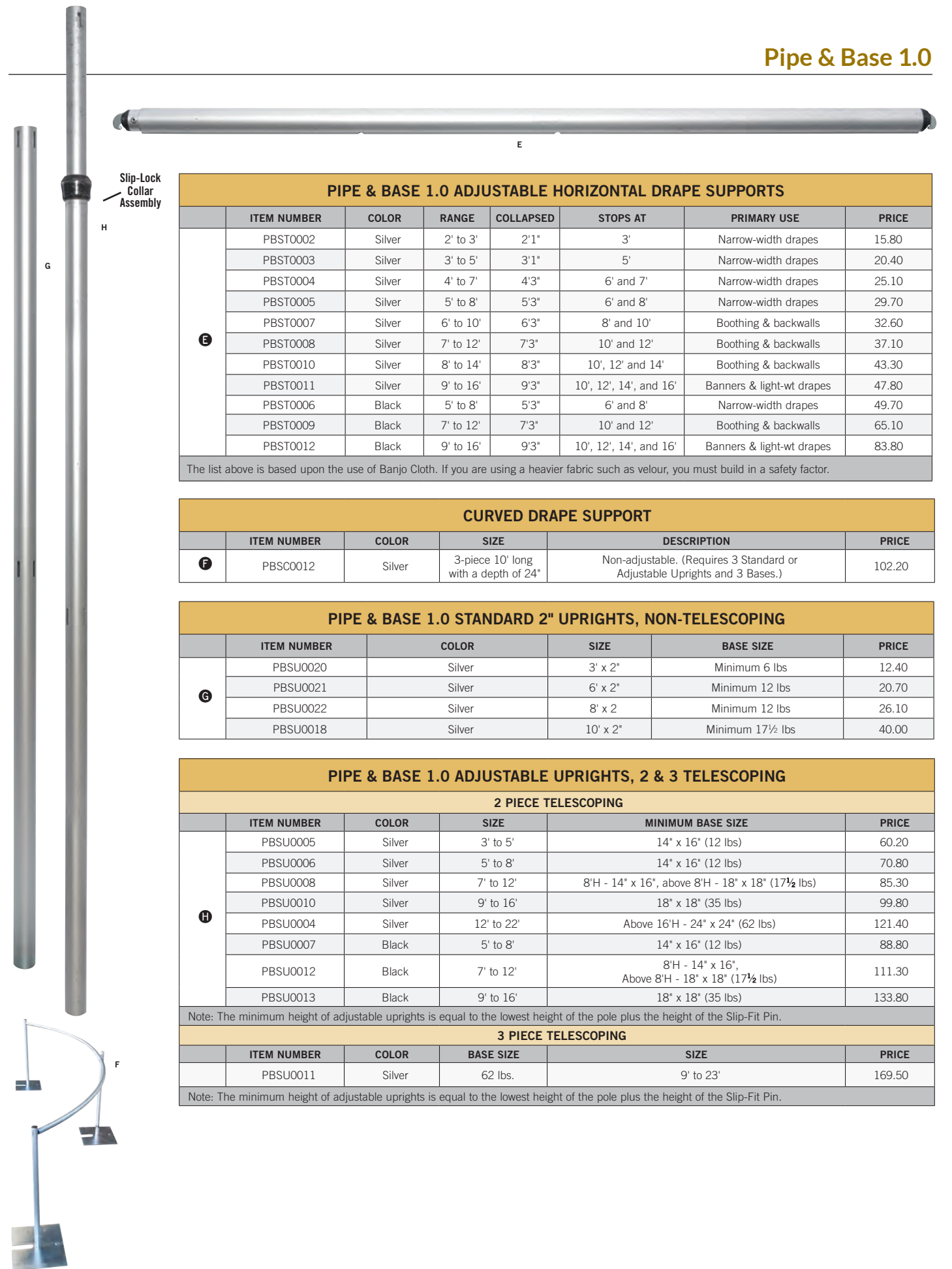

PIPE & BASE 1.0 ADJUSTABLE HORIZONTAL DRAPE SUPPORTS							
	ITEM NUMBER	COLOR	RANGE	COLLAPSED	STOPS AT	PRIMARY USE	PRICE
<b>E</b>	PBST0002	Silver	2' to 3'	2'1"	3'	Narrow-width drapes	15.80
	PBST0003	Silver	3' to 5'	3'1"	5'	Narrow-width drapes	20.40
	PBST0004	Silver	4' to 7'	4'3"	6' and 7'	Narrow-width drapes	25.10
	PBST0005	Silver	5' to 8'	5'3"	6' and 8'	Narrow-width drapes	29.70
	PBST0007	Silver	6' to 10'	6'3"	8' and 10'	Boothing & backwalls	32.60
	PBST0008	Silver	7' to 12'	7'3"	10' and 12'	Boothing & backwalls	37.10
	PBST0010	Silver	8' to 14'	8'3"	10', 12' and 14'	Boothing & backwalls	43.30
	PBST0011	Silver	9' to 16'	9'3"	10', 12', 14', and 16'	Banners & light-wt drapes	47.80
	PBST0006	Black	5' to 8'	5'3"	6' and 8'	Narrow-width drapes	49.70
	PBST0009	Black	7' to 12'	7'3"	10' and 12'	Boothing & backwalls	65.10
	PBST0012	Black	9' to 16'	9'3"	10', 12', 14', and 16'	Banners & light-wt drapes	83.80

The list above is based upon the use of Banjo Cloth. If you are using a heavier fabric such as velour, you must build in a safety factor.

CURVED DRAPE SUPPORT					
	ITEM NUMBER	COLOR	SIZE	DESCRIPTION	PRICE
<b>F</b>	PBSC0012	Silver	3-piece 10' long with a depth of 24"	Non-adjustable. (Requires 3 Standard or Adjustable Uprights and 3 Bases.)	102.20

PIPE & BASE 1.0 STANDARD 2" UPRIGHTS, NON-TELESCOPING					
	ITEM NUMBER	COLOR	SIZE	BASE SIZE	PRICE
<b>G</b>	PBSU0020	Silver	3' x 2"	Minimum 6 lbs	12.40
	PBSU0021	Silver	6' x 2"	Minimum 12 lbs	20.70
	PBSU0022	Silver	8' x 2"	Minimum 12 lbs	26.10
	PBSU0018	Silver	10' x 2"	Minimum 17 1/2 lbs	40.00

PIPE & BASE 1.0 ADJUSTABLE UPRIGHTS, 2 & 3 TELESCOPING					
2 PIECE TELESCOPING					
	ITEM NUMBER	COLOR	SIZE	MINIMUM BASE SIZE	PRICE
<b>H</b>	PBSU0005	Silver	3' to 5'	14" x 16" (12 lbs)	60.20
	PBSU0006	Silver	5' to 8'	14" x 16" (12 lbs)	70.80
	PBSU0008	Silver	7' to 12'	8'H - 14" x 16", above 8'H - 18" x 18" (17 1/2 lbs)	85.30
	PBSU0010	Silver	9' to 16'	18" x 18" (35 lbs)	99.80
	PBSU0004	Silver	12' to 22'	Above 16'H - 24" x 24" (62 lbs)	121.40
	PBSU0007	Black	5' to 8'	14" x 16" (12 lbs)	88.80
	PBSU0012	Black	7' to 12'	8'H - 14" x 16", Above 8'H - 18" x 18" (17 1/2 lbs)	111.30
	PBSU0013	Black	9' to 16'	18" x 18" (35 lbs)	133.80

Note: The minimum height of adjustable uprights is equal to the lowest height of the pole plus the height of the Slip-Fit Pin.

3 PIECE TELESCOPING					
	ITEM NUMBER	COLOR	BASE SIZE	PRICE	
	PBSU0011	Silver	62 lbs.	9' to 23'	169.50

Note: The minimum height of adjustable uprights is equal to the lowest height of the pole plus the height of the Slip-Fit Pin.



## Load In/Load Out Supplies



### UPRIGHT & DRAPE SUPPORT BAGS

For easy storage and transport of P&B hardware. Holds up to ten adjustable uprights or twenty telescopic drape supports (or some combination.) 8" diameter. Available in two sizes: 88" or 110". Go to [Rosebrand.com](http://Rosebrand.com) for a full list of all Pipe & Base Components.

	Price
88" Bag	140.00
110" Bag	150.00



### BASE BAG

For easy transport of small quantity of bases and pins. Reinforced corners. 19" x 19". Holds up to two 35 lb. or four 17 lb. bases with pins.

	Price
	66.00

Additional Hooks, Clamps, Easels and Sign Bases now on [RoseBrand.com](http://RoseBrand.com)



### NFG TAPE

The perfect case tag for that...ahem...“Non-Functioning Gear.” This fluorescent orange 2" wide Pro-Gaffer's Tape is printed with NFG every 12" for easy identification. Simply tear off the desired amount and apply to a road box. Use more or less depending on your level of frustration!

	Price
25 yd. roll	16.98



### BASE PLATE BOXES

35 lb Base Box 25 1/2" x 21" x 26" - Holds (36) - 17 lb Bases & Pins or (18) - 35 lb Bases & Pins  
62 lb Base Box 28" x 22" x 32" - Holds (8) - 62 lb Bases & Pins

	Price
	950.00
	977.00

### LONG HARDWARE BOXES (Uprights & Drape Supports/Horizontal)

7' Case (7' Long Hardware Box 90" x 18" x 27" - holds up to 7' uprights, including repair ends.)  
9' Case (9' Long Hardware Box 114" x 18" x 27" - holds up to 9' uprights, including repair ends.)

	Price
	1,407.00
	1,560.00

### DRAPE BOX

Our carpet-lined standard rental drape box includes a removable lid and will hold approx. 190 lbs. to 225 lbs. of drapes. 44" x 29" x 35".

	Price
	940.00

### SADDLEBAG /SHOT BAG/ SMALL HARDWARE BOX

This sturdy, general purpose box can accommodate approximately 35 saddlebag type Shot Bags weighing 25 lbs. per bag or 50 saddlebag Shot Bags weighing 15 lbs. per bag. 29" x 20 3/4" x 25 1/2".

	Price
	735.00

## Sand Bags



SAND BAGS			
ITEM	ITEM/DESCRIPTION	SIZE	PRICE
A	<b>FILM &amp; VIDEO FILLED SANDBAG</b> Constructed from Cordura, equipped with two carry handles. Other sizes and styles available by special order.	15 lbs	41.00
		25 lbs	49.00
B	<b>FILLED STEEL SHOT BAG</b> Film and video style. Constructed from Cordura, equipped with two carry handles. The two-sectioned saddle bag has the steel shot inside plastic bags for extra protection. Other sizes and styles available by special order.	15 lbs	61.00
		25 lbs	85.00
C	<b>FILM &amp; VIDEO SANDBAG UNFILLED</b> Used on boom stands and stage braces, where the flexible bag can mold around the brace or boom to provide stability. Must be sewn shut.	Unfilled 15 lbs	24.00
		Unfilled 25 lbs	40.00
D	<b>FILM &amp; VIDEO SANDBAG UNFILLED</b> Refillable with hook and loop closures.	Unfilled 10 lbs	26.25
		Unfilled 25 lbs	37.80
		Unfilled 50 lbs	57.75
E	<b>BASE SAND BAG UNFILLED</b> Fits 18" x 18" base or smaller. "D" ring can be used as an anchor point. Can also be used as a saddlebag. Hook and loop closures on 2 sides.	Unfilled 35 lbs	46.00



Product: ADC 140 Series Track



# Rentals

- Black Masking Curtain Rentals.....222
- Drapery & Swag Rentals .....224
- Velour & Masking Curtains Rentals..... 225
- Silk Curtains Rentals ..... 225
- Metallic Curtains Rentals ..... 225
- Cyc Curtain Rentals ..... 225
- Sheer Curtain Rentals..... 225
- Satin Curtain Rentals ..... 225
- Swag Curtain Rentals ..... 225
- Scrim Curtain Rentals..... 225
- Rain Curtain Rentals ..... 225
- Austrian Curtain Rentals..... 225
- LED Star Drops & Animation Curtain Rentals .....226
- Metal Beaded Swag Rentals.....226
- FXs Rentals.....228
- Rose Brand Kabuki System ..... 228
- Snow & Confetti Machine..... 228
- Pipe & Base 2.0 Rentals .....228
- Curtain Track Rentals .....229
- Track In A Box ..... 229
- ADC 280 Heavy Duty Curtain Track ..... 229



ORDER RENTALS  
CATALOG ONLINE

**LARGEST RENTAL  
INVENTORY.  
FASTER DELIVERY.  
PERFECT DRAPES.  
EVERY TIME.**

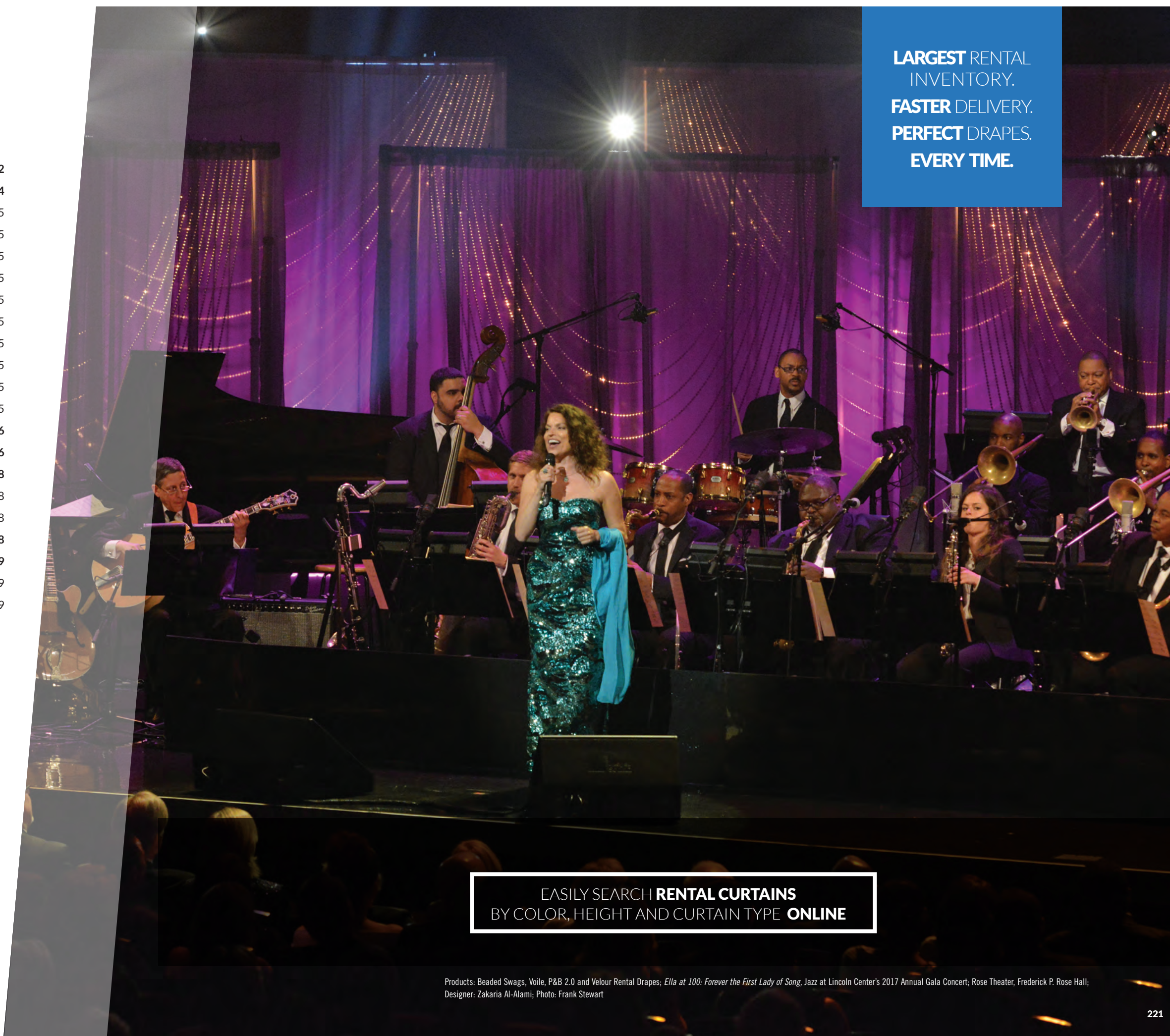

EASILY SEARCH **RENTAL CURTAINS**  
BY COLOR, HEIGHT AND CURTAIN TYPE **ONLINE**

Products: Beaded Swags, Voile, P&B 2.0 and Velour Rental Drapes; *Ella at 100: Forever the First Lady of Song*, Jazz at Lincoln Center's 2017 Annual Gala Concert; Rose Theater, Frederick P. Rose Hall; Designer: Zakaria Al-Alami; Photo: Frank Stewart

- Fabrics
- Black Masking
- Custom Stage Curtains & Backdrops
- Custom Special Event Sewing
- Digital Printing
- LED Star Drops
- Pipe & Base
- Rentals**
- Projection Materials
- Flooring
- Curtain Track
- Stage Equipment, FXs & Mirrors
- DMX Winches
- Scenery Props
- Shop & Production Supplies
- Tape
- Film & Video Supplies
- Index



# Black Masking Curtain Rentals

Event planners and designers often work on tight timetables and budgets. Trust Rose Brand for a bit of stress relief...

- Largest inventory of rental curtains and event drapery
- Fast turnaround on orders
- Items checked for perfect condition before shipping
- Items labeled for exact placement in your venue to speed load-in and lower setup costs

Whether you need a single curtain panel or a mile of 30' high drapes we have a broad range of colors and textures. Start your search by going to Rental Curtain and Drape Finder on RoseBrand.com. Our inventory is located on both the East and West Coasts, so it ships quickly to US destinations. Rose Brand can handle even the largest orders with just a couple of days notice.

Product: 15 oz. Encore; Photo: Angelo Petratos

**Rose Brand Rentals**  
Rose Brand drapery rentals shop prep assures faster, more confident load-in.  
All road boxes labeled for contents & specific location within your venue.  
All drapery & equipment inspected for quality before it's packed & shipped.



**Rose Brand Rentals. Trust the yellow road box.™**

Fabrics
Black Masking
Custom Stage Curtains & Backdrops
Custom Special Event Sewing
Digital Printing
LED Star Drops
Pipe & Base
<b>Rentals</b>
Projection Materials
Flooring
Curtain Track
Stage Equipment, FXs & Mirrors
DMX Winches
Scenery Props
Shop & Production Supplies
Tape
Film & Video Supplies
Index



# Drapery & Swag Rentals

EASILY SEARCH  
**RENTAL CURTAINS**  
BY COLOR,  
HEIGHT AND  
DRAPE TYPE  
**ONLINE**

## Velour & Masking Curtain Rentals



Largest inventory of picture perfect velours anywhere!

## Sheer Curtain Rentals



Control light, shadow, texture and depth with beautiful sheers.

## Silk Curtain Rentals



Crushed faux silks provide a soft, shimmery look & feel.

## Satin Curtain Rentals

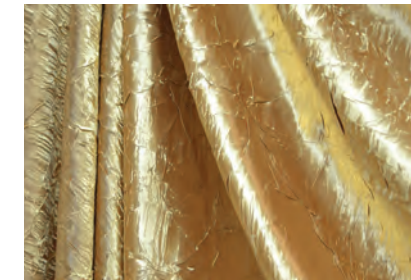

Elegant, rich, glossy and textured to catch light and add depth.

## Metallic Curtain Rentals



Metallics add sheen and sophistication to your environment.

## Swag Curtain Rentals



Use swags in end-to-end or overlapping configurations for a bold statement.

## Cyc Curtain Rentals



For projection and lighting effects. Available in heights up to 30' and widths up to 60'.

## Scrim Curtain Rentals



For projection and lighting effects. Available in heights up to 35' and widths up to 60'.

# Drapery & Swag Rentals

## How To Request A Rental Quote Online

Easily search rental curtains by Color, Height and Drape Type

1. Find products you'd like to rent
2. Add them to a Rentals Shopping List
3. Save your list as a Rentals Project to submit it for quote now or in the future.

## Rain Curtain Rentals

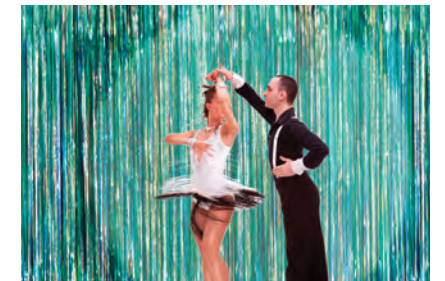

Multi-layered Rain Curtains help create a festive environment with shimmering effects.

## Austrian Curtain Rentals

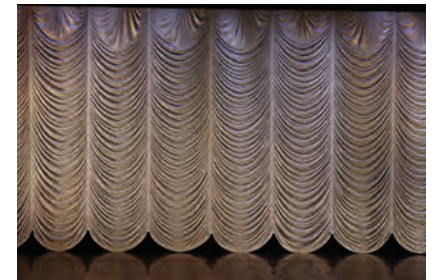

Richly pleated curtains create drama and glamour for a timeless look.



## LED Star Drops & Animation Curtain Rentals

LED and Fiber Optic Curtains make brilliant backdrops for shows, concerts and other special events. Replicate the night sky or add color, motion & animation to your production. Easy to setup and operate.

SHOWLED  
classic



Produces white LED light that can twinkle like the night sky or in specified patterns and chases, as desired.

SHOWLED  
chameleon



Produces LED light in RGB colors. Also twinkles in specified patterns and chases.

SHOWLED  
animation



Low resolution video curtain that adds color, motion & excitement to any event.

## Metal Beaded Swag Rentals



These large-scale, faceted stainless steel beads are highly reflective for dynamic lighting effects.

Use a single swag for a touch of glamour or combine multiple swags for a truly regal look. Add many sections or just a few to create the look you want.

Dramatic deep expressionist Tergalet swags designed to be used as contrasting backing for our Beaded Swags can also be used on their own. Like the Beaded Swags, these versatile swags can be tied to vary the depth and width to suite your design.



Product: Metal Beaded Curtain; *Project Runway All Stars Finale*, Gum Studios; Production Designer: Kristen Adams; Lighting Designer: Gus Dominguez; Art Production Supervisor: Liz Flood; Executive Producer: Rob Bagshaw; Director: Michael Pearlman; Line Producer: Cosmo DeCeglie; Photo: Greg Endries

## Metal Beaded Swag Rentals

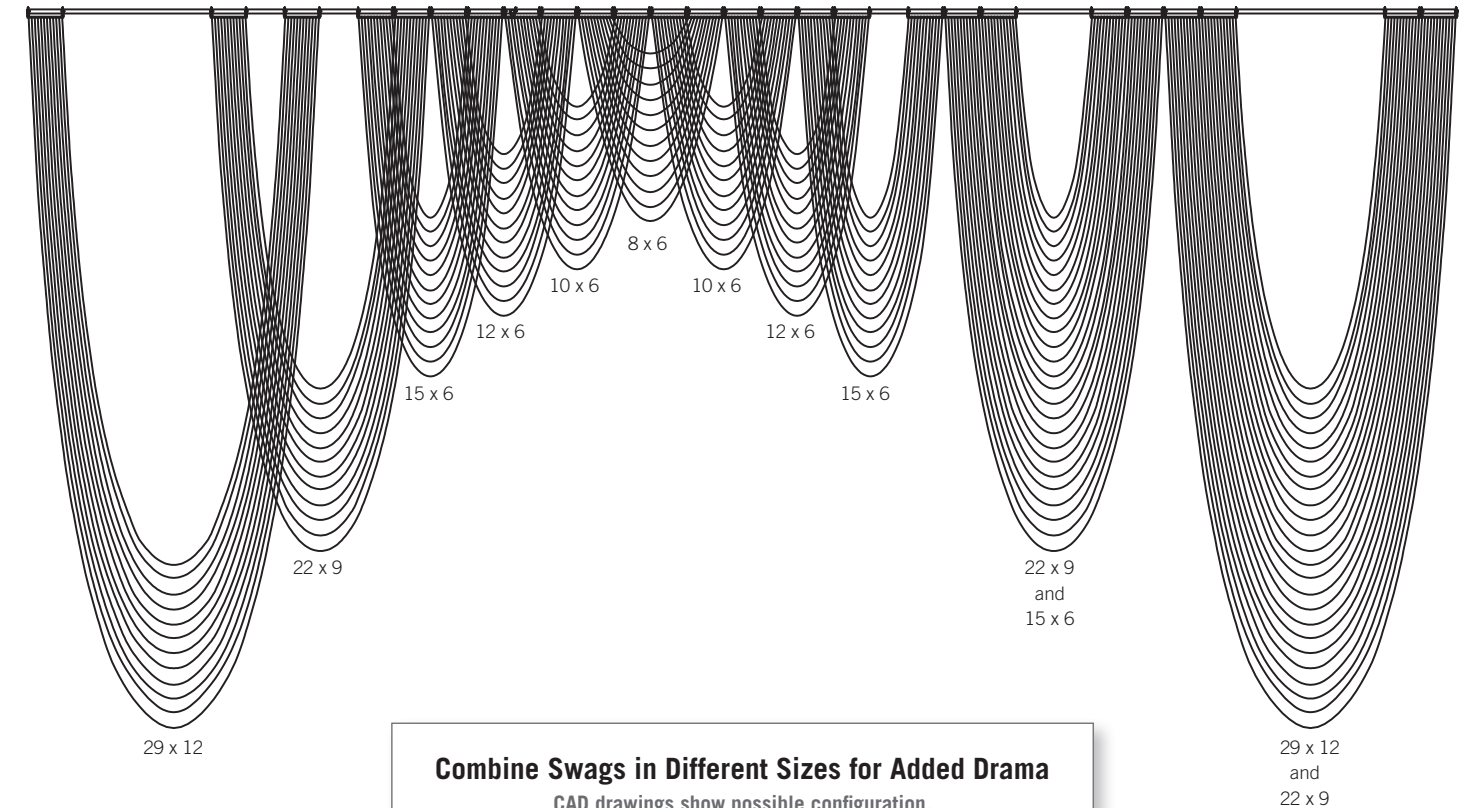
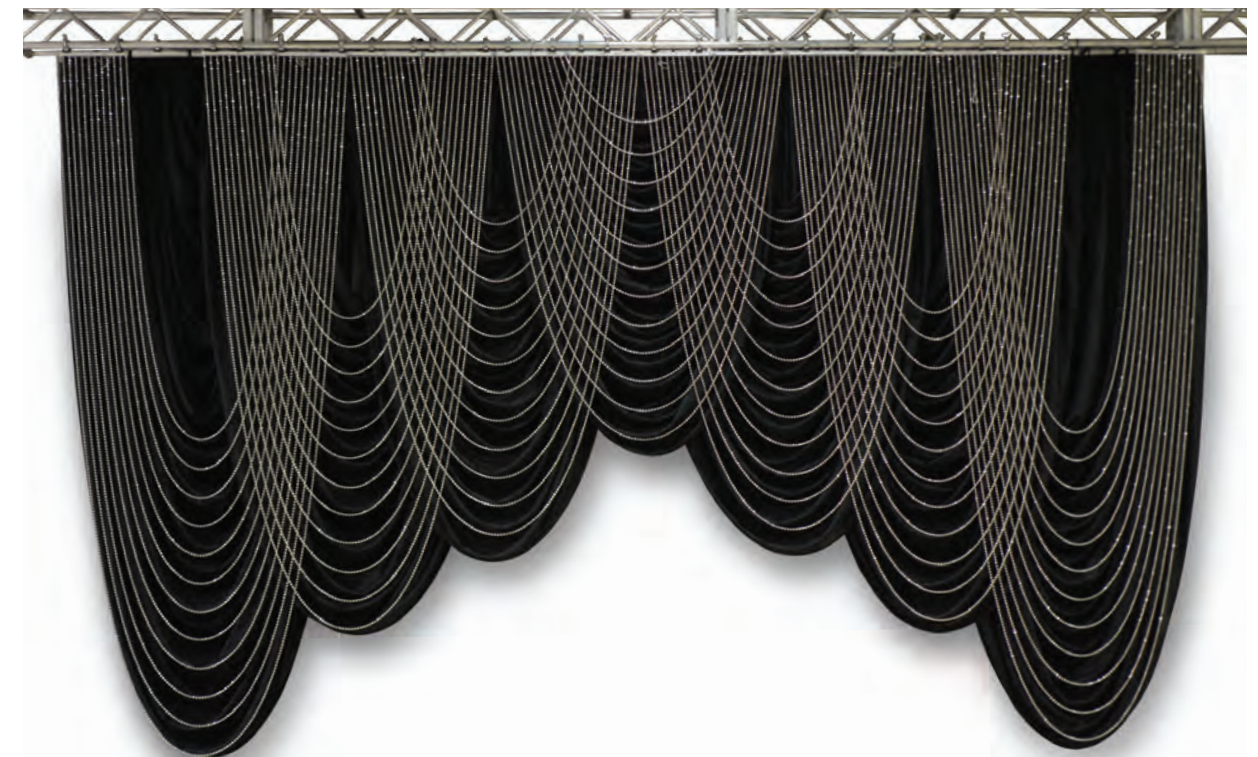

**Combine Swags in Different Sizes for Added Drama**

CAD drawings show possible configuration.  
Additional configurations shown at [Rosebrand.com](http://Rosebrand.com).

Fabrics
Black Masking
Custom Stage Curtains & Backdrops
Custom Special Event Sewing
Digital Printing
LED Star Drops
Pipe & Base
Rentals
Projection Materials
Flooring
Curtain Track
Stage Equipment, FXs & Mirrors
DMX Winches
Scenery Props
Shop & Production Supplies
Tape
Film & Video Supplies
Index



## FXs Rentals

Create dramatic experiences with easy to use FX systems.

### Rose Brand Kabuki System



The Kabuki drop provides dramatic reveals through the use of a lightweight curtain that initially hides what's behind it, and then quickly drops to the floor. Our system is modular, easy to setup and simple to deploy. Comes with everything except the curtain, which we can produce for you separately.

### SnowStar



This simple and modular system drops paper snow or confetti to create effects that range from a sprinkle to a blizzard. Connect multiple units to expand the effect across an entire stage or event area.

## Pipe & Base 2.0 Rentals

Create gorgeous, quick & easy room décor or masking with Pipe & Drape solutions. Simply combine any of the drapery described on the preceding pages with Pipe & Base 2.0 hardware. Rental drapery is all sewn flat, so you can easily gather it to achieve the precise amount of fullness that you desire.

### Adjustable Horizontal Drape

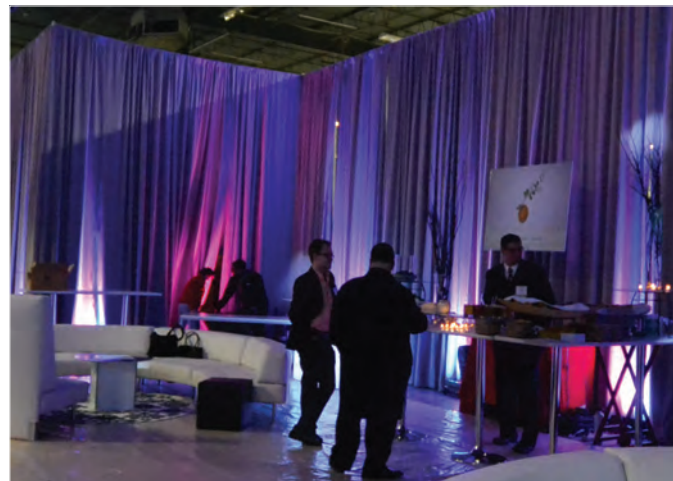

Adjustable uprights and supports provide the flexibility to hang drapes for both small trade show booths and large events and productions. See page 213.

### Double Drape Wall



One Sidearm connected to a single upright, creates a double drape line using Pipe & Base Sidearm accessory. See page 214.

## Curtain Track Rentals

We offer 2 varieties of track rentals.

### Track In A Box



Track In A Box is highly versatile and easy to pack & ship. It uses Triple E Unitrack, the premier system for touring & temporary installations. Quiet, heavy duty and modular.

### ADC 280 Heavy Duty Curtain Track

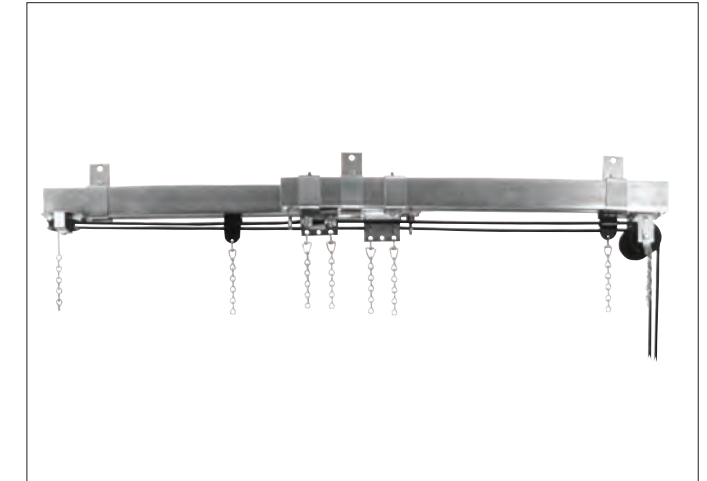

ADC Heavy Duty Track #280 is the industry standard for heavy duty, reliable, quiet curtain track.

### Request A Rental Quote Online

Add these items to your Rental Project online and we will recommend the appropriate quantity when we discuss your quote request with you.



# Projection Materials

- Projection Overview ..... 232
- Darknet™ Projection Fabrics..... 234
- Rear Projection Screens..... 236
- Front Projection Screens..... 238
- Extra Wide Projection Screens ..... 240
- Rosco Projection Screens .....241
- Rose Brand Projection Fabrics ..... 243
- Screen Goo Projection Paints..... 244
- The Rose Brand Stretcher Frame System ..... 248
- Components and Kit .....249
- Curtain Finish Details ..... 249



Product: Extra Wide Light Grey Muslin. A general session set in the Mercedes-Benz Stadium for a client of The XD Agency.

- Fabrics
- Black Masking
- Custom Stage Curtains & Backdrops
- Custom Special Event Sewing
- Digital Printing
- LED Star Drops
- Pipe & Base
- Rentals
- Projection Materials
- Flooring
- Curtain Track
- Stage Equipment, FXs & Mirrors
- DMX Winches
- Scenery Props
- Shop & Production Supplies
- Tape
- Film & Video Supplies
- Index



## Projection Overview



Products: Front White/Black-160B IFR Front Projection Screen; Jesus, Jonah; Sight & Sound Theatres – Lancaster; Scene Shop: Sight & Sound Theatres; Photo: Sight & Sound Theatres

Rose Brand specializes in Customized Projection Screens in any size or shape, welded and finished to your specifications. All screens are designed for excellent color rendering and contrast, with wide viewing angles. They're also durable, washable, and **Inherently Flame Retardant**. Send us a drawing or call us for a quote. Screen materials can also be purchased by the yard.

We carry different lines of projection screen materials to satisfy every need.

See more information on each of the product lines on the pages that follow.

- Rose Brand® Darknet™ Projection Fabrics – FX Projection Nettings.
- Rose Brand® Premium Projection Screens – highest quality custom PVC screen available.
- Rosco Projection Screens – our classic PVC screen.
- Extra Wide Projection Screens – for building into sets.
- Rose Brand® Projection Fabrics – lightweight, portable & extra-wide widths for seamless projection quality
- Screen Goo – High performance projection coatings. Turns virtually any surface into a high-gain projection screen. Ideal for 3D mapping.
- The Rose Brand® Stretcher Frame System – fixes extreme hourglassing.



Bottom Photo Products: 22 oz. Encore, Muslin; Jesus, Jonah; Sight & Sound Theatres – Lancaster; Scene Shop: Sight & Sound Theatres; Photo: Sight & Sound Theatres

Fabrics
Black Masking
Custom Stage Curtains & Backdrops
Custom Special Event Sewing
Digital Printing
LED Star Drops
Pipe & Base
Rentals
Projection Materials
Flooring
Curtain Track
Stage Equipment, FXs & Mirrors
DMX Winches
Scenery Props
Shop & Production Supplies
Tape
Film & Video Supplies
Index



# Darknet™ Projection Fabrics

**NEW DARKNET  
FABRICS MAKE  
PROJECTION IMAGES  
SEEM TO FLOAT  
IN MIDAIR**

SHOWN AT ACTUAL SIZE | Darknet™ Projection Fabrics



Product: 24'H x 74'W Nebula™ Projection Netting; Event: *Beyond Wonderland - The Endless Sea Rave*; Creative Director: Heather Shaw, Vita Motus Design Studio; Producer: Insomniac

## DARKNET™ PROJECTION FABRICS

Call to Order.

FABRIC	SPECIFICATIONS		
	Width	Length	Color
<b>NEBULA™ NET</b> Flame Retardant. A designer's dream, new 26' wide Nebula Net provides a high gain, see-through projection surface that's virtually undetectable to the audience. Objects seem to float in midair, or appear out of nowhere. Use Nebula Net for stunning, magical projections and holographic effects: mind blowing layered projections for concerts, or the Pepper's Ghost effect for theatre, or dramatic reveals for corporate events.	26'	90'-99'	Black
<b>SCREEN SCRIM™</b> Flame Retardant. Screen Scrim netting turns a black scrim into a high gain projection surface while still providing a magical "scrim-through effect." Because of the brighter reflectivity, designers can sustain a front projection image on the scrim even while bleeding through to a well-lit, upstage scene. Screen Scrim reads as a dark grey in comparison to traditional black scrim.	29'	180'-195'	Black
<b>IMAGE NET™</b> Flame Retardant. The bobbinette weave makes for an imperceptible yet highly reflective projection surface. The larger open cells allow for the net to be viewed off axis from the audience without revealing itself. Image Net fabric also offers superior "blowthrough" characteristics to reduce billowing in air currents. Great for stadium use.	29'	180'-196'	Black

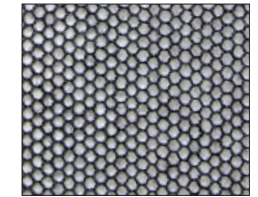

Nebula™ Net

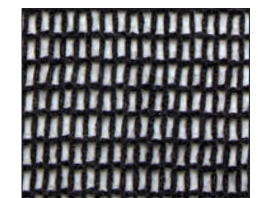

Screen Scrim™



Image™ Net

Shown at Actual Size.

Darknet™ projection fabrics offer designers a new tool to help create compelling projected effects. Black fabrics have long provided the theatrical "invisibility" relied upon by designers and technicians, but dark surfaces are notoriously difficult to project on. Our Darknet™ fabrics have been specially treated to provide a high gain, high resolution projection surface. Using these black nets, designers can build effects that surprise and delight their audiences with gorgeous rich images that jump off the screen, having seemingly appeared from nowhere.

Please call us (800-223-1624 or 201-809-1730) or email for more information and to order.

As shown in the images above and below, Creative Director Heather Shaw (Vita Motus Design Studio) used our Nebula Net to great effect at the Beyond Wonderland rave festival. Under performance lighting conditions, Nebula Net completely disappears so the audience is wowed by projected images that appear to "float in midair" at the front of the stage.

► Go to Video at <http://bit.ly/invisible-screen>



- Fabrics
- Masking
- Custom Stage Curtains & Backdrops
- Custom Special Event Sewing
- Digital Printing
- LED Star Drops
- Pipe & Base
- Rentals
- Projection Materials
- Flooring
- Curtain Track
- Stage Equipment, FXs & Mirrors
- DMX Winches
- Scenery Props
- Shop & Production Supplies
- Tape
- Film & Video Supplies
- Index



# Rear Projection Screens



PREMIUM PROJECTION SCREENS

Rose Brand Premium Projection Screens are the highest quality Custom PVC Projection Screens available:

- Superior PVC media with very consistent thickness and shade.
- Painstaking workmanship in all aspects of finishing.
- Precision ultrasonically welded seams that are practically invisible.
- Excellent gain and transmittance, with wide viewing angles.
- Virtually no limits on dimensions, shapes or side finishes.

110" material is 2 widths of 55" goods welded

**DETAILED PROJECTION DATA**  
AVAILABLE AT  
ROSEBRAND.COM

## MILK WHITE 115 - 94"

Price Per Yard: 94"/55.00

Milk White vinyl rear projection screen suitable for front or rear projection. Even light distribution makes this screen perfect for cycloramas. Avoids the warm color cast found on Cream 110 or Twin White.

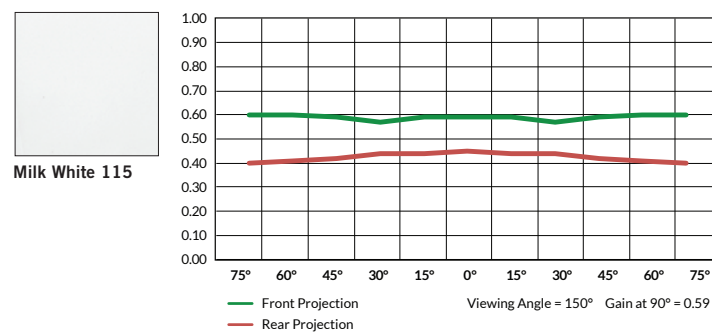

## CREAM 110 - 55"/94"/110"

Price Per Yard: 55"/18.30 94"/55.00 110"/95.00

This is the most versatile and popular screen with brilliant results for front, rear and cross fades. Also serves as a great Cyclorama/Bounce.

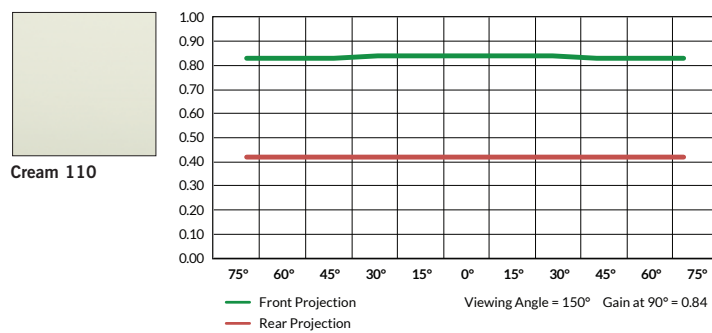

## OPERA BLUE 140 - 55"/110"

Price Per Yard: 55"/18.30 110"/95.00

A light, blue grey screen for cooler temperature. Ideal for sky effects.

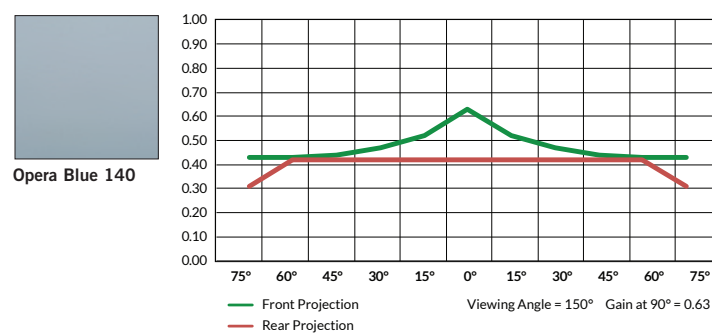

## CONTRAST GREY 120 - 55"/94"/110"

Price Per Yard: 55"/18.30 94"/55.00 110"/95.00

High contrast makes blacks darker and the neutral color is great for blending in with scenery. The best screen for outdoor applications.

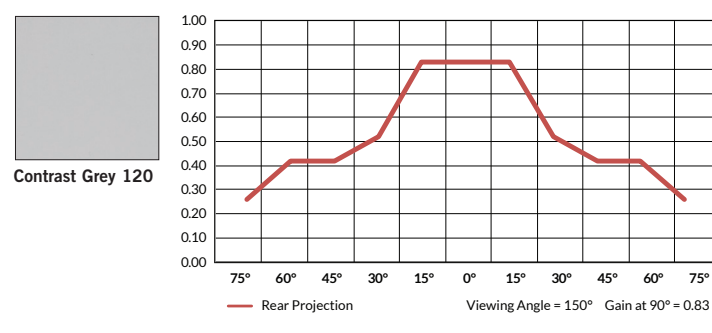

# Rear Projection Screens

## BLACK 130 - 55"/110"

Price Per Yard: 55"/18.30 110"/95.00

Great for show situations where the screen must not bounce ambient light. The screen formulation is ideal for using right in front of a video wall. It masks the individual pixels and results in a brilliant image with high contrast.

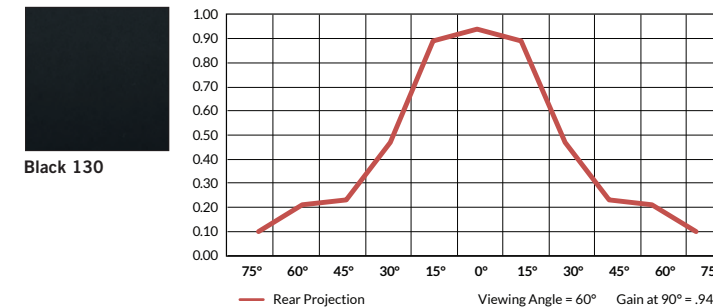

## TRANSLUCENT 150 - 55"/110"

Price Per Yard: 55"/18.30 110"/95.00

For projection situations with high ambient light. Also great for color washes, gobos and many other lighting effects.

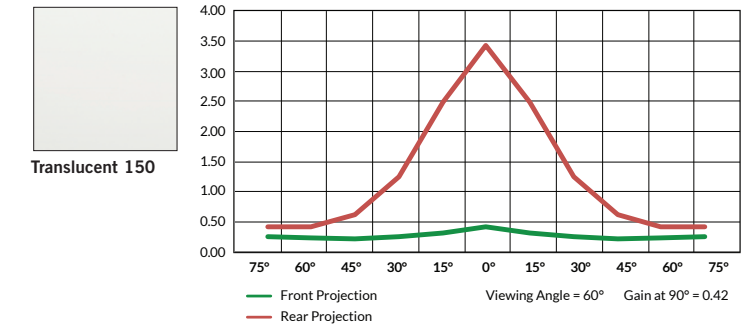

## LIGHT ICE 155 LED DIFFUSER - 55"

Price Per Yard: 55"/18.30

Translucent vinyl screen designed to de-pixelate LED walls without compromising clarity and brightness. Eliminates moiré on camera.

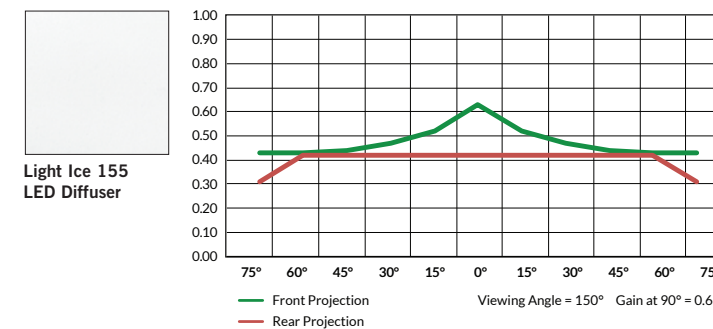

## GLASS CLEAR - 51"

Price Per Yard: 51"/18.30

A clear vinyl screen for special projection effects such as rain, mist and fog. Also useful in set construction as a less expensive alternative to PlexiGlass™ when painting and distressing windows.



Call about Custom Manufacturing

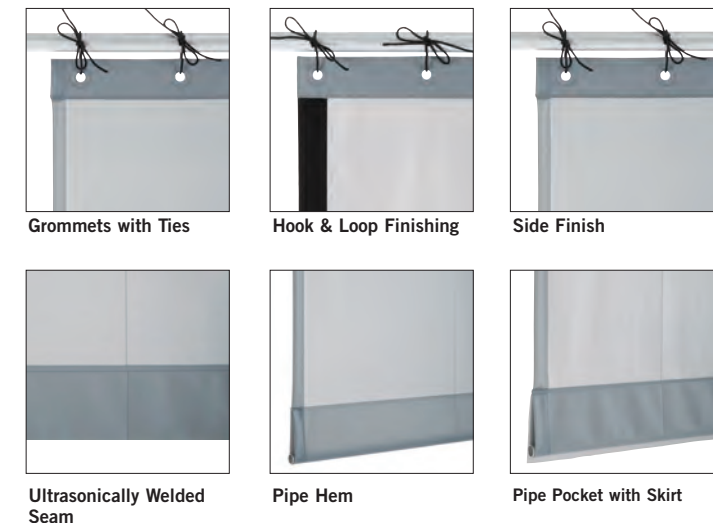

## Top, Side and Bottom Finishes

Select from the top, bottom and side finishes at left for your custom projection screen. Other custom finishing options are also available.



Manufacturing High Contrast Grey-120 Screen

- Fabrics
- Black Masking
- Custom Stage Curtains & Backdrops
- Custom Special Event Sewing
- Digital Printing
- LED Star Drops
- Pipe & Base
- Rentals
- Projection Materials
- Flooring
- Curtain Track
- Stage Equipment, FXs & Mirrors
- DMX Winches
- Scenery Props
- Shop & Production Supplies
- Tape
- Film & Video Supplies
- Index



# Front Projection Screens



110" material is 2 widths of 55" goods welded

**DETAILED PROJECTION DATA AVAILABLE AT ROSEBRAND.COM**

**WHITE 160 - 55"/110"**  
Price Per Yard: 55\*/18.30 110\*/95.00

The standard for front projection where high gain is needed.

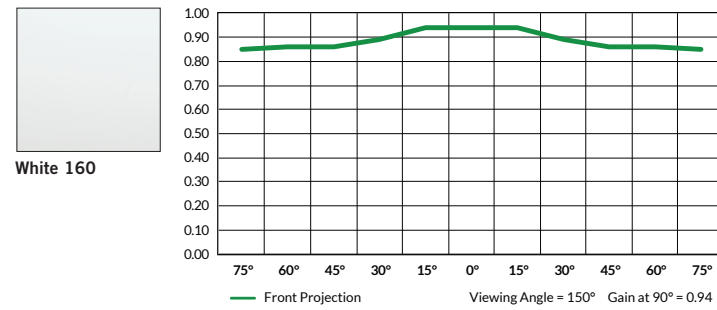

**WHITE 160 - 86"**  
Price Per Yard: 86\*/55.00

The standard for front projection where high gain is needed.

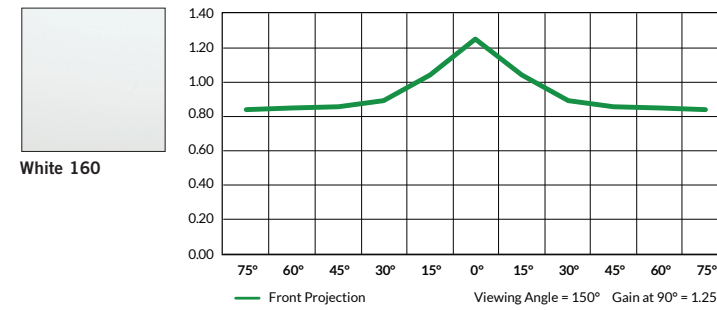

**WHITE SAND 165 - 94"**  
Price Per Yard: 94\*/65.00

Front white with a subtle embossed texture for maximum reduction of glare and reflections. Wide width and soft hand.

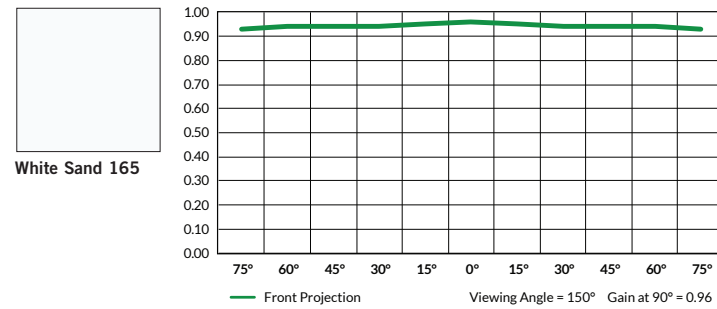

**WHITE/BLACK 160B - 82"**  
Price Per Yard: 82\*/70.00

Front White Projection screen with opaque black backing. Foldable for easy transport and lower shipping costs.

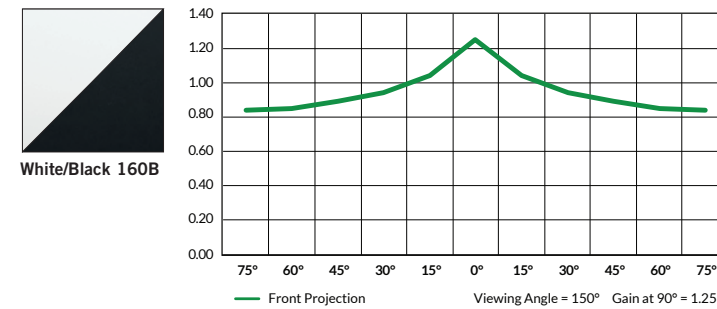

**WHITE 170 PERFORATED - 55"/110"**  
Price Per Yard: 55\*/28.00 110\*/95.00

For acoustic transparency when placing speakers behind the screen.

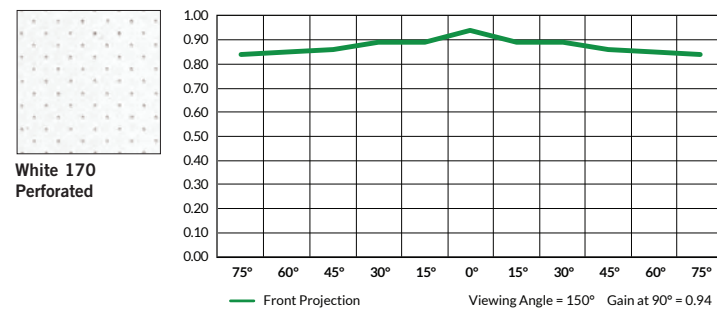

**WHITE 180 MICRO-PERFORATED - 86"**  
Price Per Yard: 86\*/85.00

Acoustic perforations that are virtually invisible make this an ideal screen for home theaters where the audience is close.

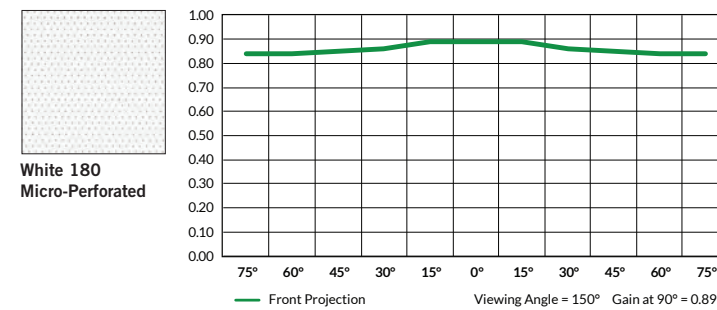

# Front Projection Screens

**GREY SUEDE 185 - 94"**  
Price Per Yard: 94\*/65.00

Front grey screen with wide viewing angle and excellent color fidelity. A fine embossed texture reduces screen glare. Wide width and a soft hand.

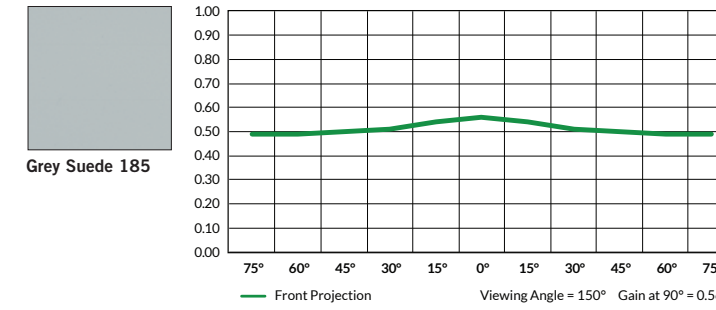

**BLACK 190 - 55"/110"**  
Price Per Yard: 55\*/28.00 110\*/95.00

A unique, textured surface results in unusual gain from a black medium.

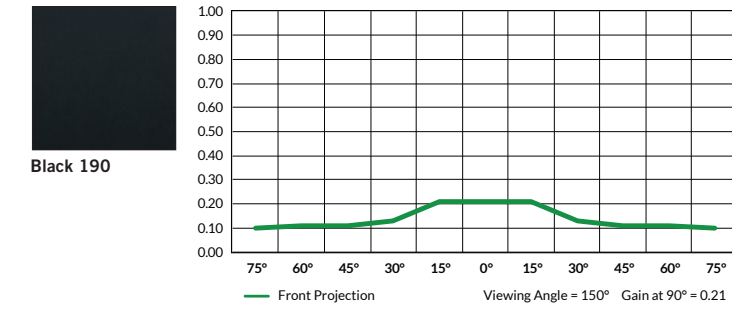

Products: Black Front 190 Projection Screen, Princess Velour; *Dear Evan Hansen*, The Music Box; Designer: David Korins; Scene Shop: PRG Scenic Technologies, Daedalus Design & Production; Photo: David Korins Design

- Fabrics
- Black Masking
- Custom Stage Curtains & Backdrops
- Custom Special Event Sewing
- Digital Printing
- LED Star Drops
- Pipe & Base
- Rentals
- Projection Materials
- Flooring
- Curtain Track
- Stage Equipment, Fx's & Mirrors
- DMX Winches
- Scenery Props
- Shop & Production Supplies
- Tape
- Film & Video Supplies
- Index



# Extra Wide Projection Screens

## WHITE 260 FRONT SCREEN - 120"

Price Per Yard: 120"/47.00

Extra-wide high gain Front White screen. The 10' width makes this a great choice for scenery and framed units.  
(Note: 10' screen material is available as cut yardage only and cannot be used for custom screens.)

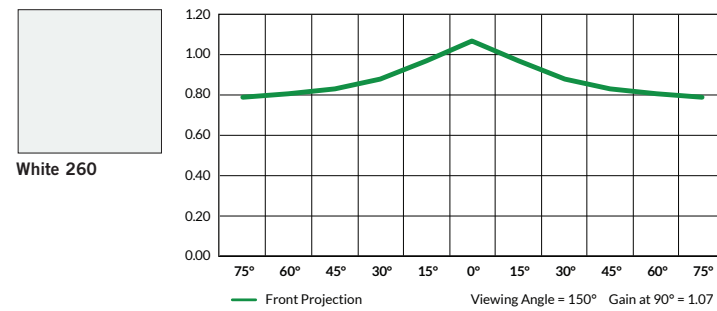

## HD GREY 225 FRONT SCREEN - 120"

Price Per Yard: 120"/55.00

Extra-wide Front Grey screen. The 10' width makes this a great choice for scenery and framed units.  
(Note: 10' screen material is available as cut yardage only and cannot be used for custom screens.)

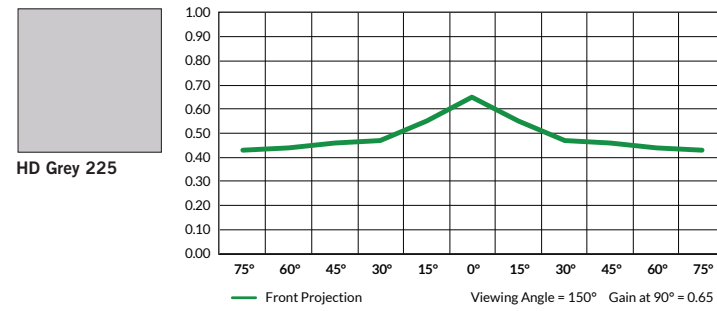

## CONTRAST GREY 220 REAR SCREEN - 120"

Price Per Yard: 120"/55.00

Extra-wide Grey Rear Screen. The 10' width makes this a great choice for scenery and framed units.  
(Note: 10' screen material is available as cut yardage only and cannot be used for custom screens.)

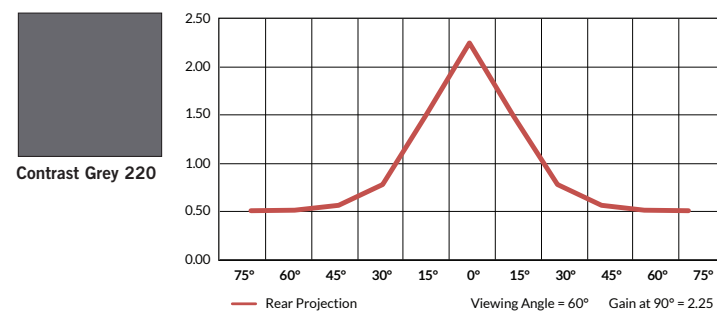

## WHITE/GREY 260G FRONT SCREEN - 120"

Price Per Yard: 120"/65.00

Extra-wide high gain Front White screen with an opaque grey backing. The 10' width makes this a great choice for scenery and framed units.  
(Note: 10' screen material is available as cut yardage only and cannot be used for custom screens.)

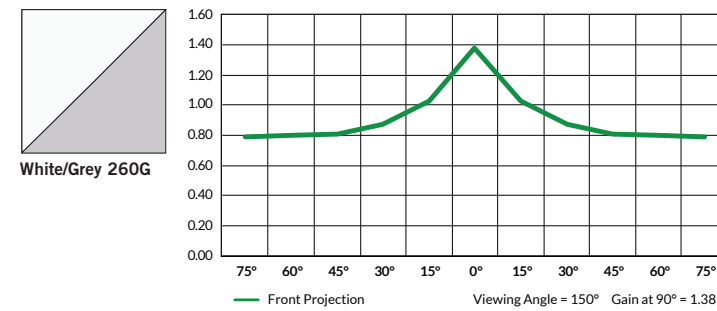

## CREAM 210 - 120"

Price Per Yard: 120"/55.00

Extra-wide Cream Screen suitable for front or rear projection use. The 10' width makes this a great choice for scenery and framed units.  
(Note: 10' screen material is available as cut yardage only and cannot be used for custom screens.)

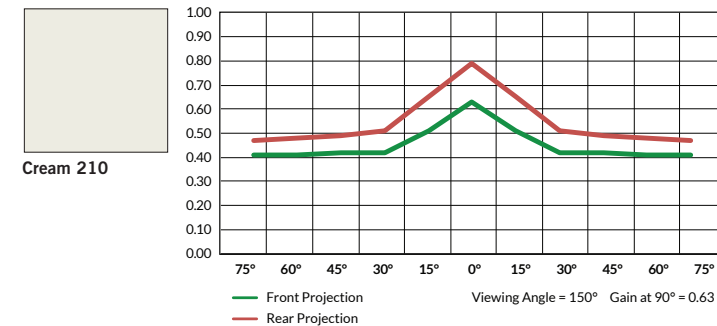

## BLACK 230 REAR SCREEN - 120"

Price Per Yard: 120"/55.00

Extra-wide Black Rear Screen. The 10' width makes this a great choice for scenery and framed units.  
(Note: 10' screen material is available as cut yardage only and cannot be used for custom screens.)

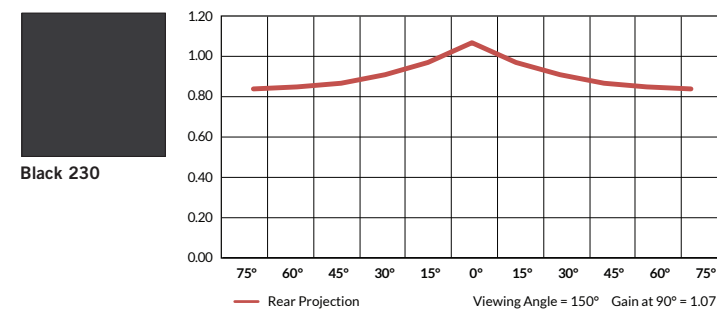

# Rosco Projection Screens

## ROSCO TWIN WHITE - 55"/86"

Finished screens only, cut yardage not available.

This versatile screen's milky white color makes for equally bright, crisp images whether front or rear projected.

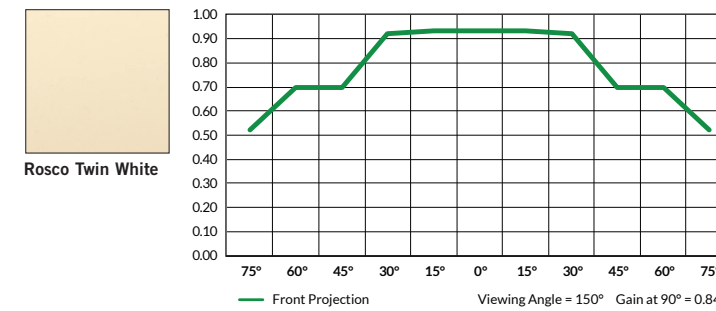

## ROSCO BLACK - 55"

Finished screens only, cut yardage not available.

For situations where there are high quantities of ambient light.

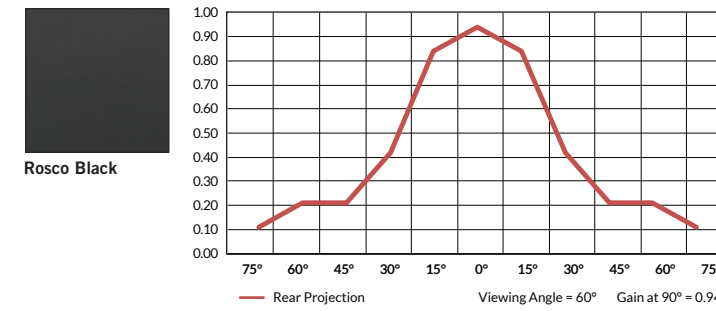

## ROSCO WHITE FRONT - 55"/93"

Finished screens only, cut yardage not available.

Highly reflective, matte white material best used where a bright image and wide viewing cone is required.

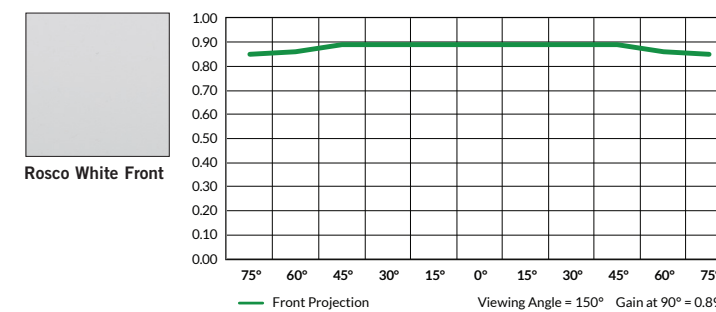

## ROSCO GREY - 55"

Finished screens only, cut yardage not available.

The color blends the screen into the scenery and provides higher contrast than white.

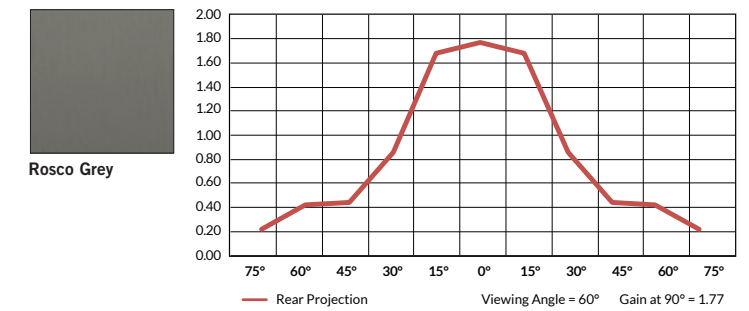

## ROSCO LIGHT TRANSLUCENT - 55"

Finished screens only, cut yardage not available.

Light grey screen for a wide variety of scenic uses.

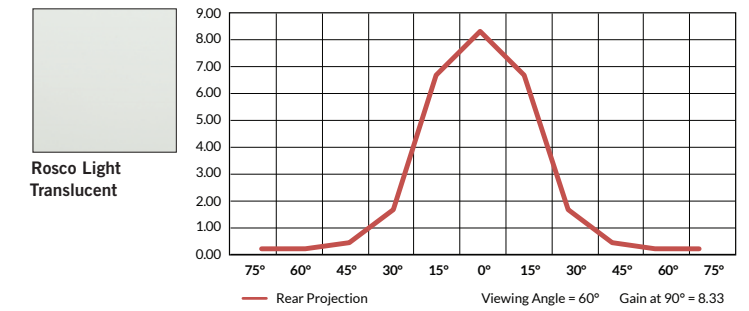



## Rose Brand Projection Fabrics

We've seen designers project onto many of our fabrics with spectacular results. We can cut and/or finish any of these fabrics to your specifications, all of which are available in wide dimensions for seamless screen production.

### SEAMLESS FABRICS FOR PROJECTION

FABRIC TYPE	WIDTH	COLORS	FABRIC PHOTO
<b>FRONT PROJECTION FABRICS</b>			
EXTRA WIDE MUSLIN	Multiple widths See pages 56-57	White, Lt. Grey	See page 56
TIGHT WEAVE MUSLIN	Multiple widths See pages 56-57	White, Lt. Grey	See page 57
EXTRA WIDE CANVAS	Multiple widths See page 53	White	See page 53
BOOST	122"	White	See page 75
		Grey	
POLY CYC	128"	White, Lt. Grey	See page 128
CELTIC CLOTH CONTRAST GREY	122"	Contrast Grey	See page 78
CELTIC CLOTH WHITE	122"	White	See page 78
	13' 4"	White	See page 78
	16'	White	See page 78
BLACKOUT LINING	110"	White/White	See page 45
SOFTSCREEN	122"	White	See page 79
AGLO® WHITE (FRONT OR REAR PROJECTION)	122"	White	See page 78
	16' 4"	White	See page 78
BLOW THROUGH™	15'	White	See page 81
HALO	118"	White, Contrast Grey	See page 79
WHITE BLACKOUT SATEEN	118"	White	See page 80
NEW WHITEOUT	16' 4"	White	See page 79

### SEAMLESS FABRICS FOR LIGHTING EFFECTS

FABRIC TYPE	WIDTH	COLORS	FABRIC PHOTO
These fabrics all have a textural quality. Each adds its own distinctive visual enhancement to the projected image.			
SHARKSTOOTH SCRIM	Multiple sizes See page 60	White, Lt. Grey	See page 60
SQUARE GAUZE	35'	White	See page 64
LUSTRE NET	118"	White, Assorted colors	See page 121
SCENERY NETTING	13' 3"	White	See page 64
SUPERSILK	16' 6"	White	See page 95
ALLEGRO	119"	White, Lt. Grey	See page 95
RADIANCE	120"	White, Lt. Grey	See page 109
CRUSHED VOILE	114"	White, Lt. Grey	See page 91
SHIMMER VOILE	118"	Charcoal Grey	See page 83
TERGALET	106"	White, Assorted colors	See page 98
TEXTILENE®	98"	White, Silver	See page 130
KAOS	118"	Natural, Grey, Black	See page 69
<b>OUTDOOR PROJECTION MATERIALS AVAILABLE</b>			
Go to <a href="http://RoseBrand.com">RoseBrand.com</a> for more information.			

**TIP:**  
Choose grey colored fabrics, as opposed to white, if your ambient light levels are high and you'd like to increase the contrast between light and dark colors in your projection.

- Fabrics
- Black Masking
- Custom Stage Curtains & Backdrops
- Custom Special Event Sewing
- Digital Printing
- LED Star Drops
- Pipe & Base
- Rentals
- Projection Materials
- Flooring
- Curtain Track
- Stage Equipment, FXs & Mirrors
- DMX Winches
- Scenery Props
- Shop & Production Supplies
- Tape
- Film & Video Supplies
- Index



# Screen Goo Projection Paints

**EASIER, FASTER  
SHARPER  
INTRODUCING  
SCREEN GOO 2.0**



# screen goo 2.0

For more than 10 years, projection experts have used Screen Goo coatings to create a high performance projection screen on virtually any surface, no matter the shape, size or geometry. Rigorous research and development has resulted in a new formulation that improves the original product in several key ways.

**Screen Goo 2.0 is now a single step application.** The previous base coat + finish coat system has been replaced by a single formulation. A dramatic time savings!

**Screen Goo 2.0 has longer open time - 5X longer than the original.** This virtually eliminates brush and roller marks and textural artifacts. This flatter, smoother coating means crisper image quality and sharper definition. The increased open time makes it possible to paint even extremely large areas without compromising the finish quality.

**Screen Goo 2.0 has updated its chemistry** resulting in stronger color saturation, richer contrast and more improved color fidelity. These benefits are especially apparent with 4K UHD and Dolby Vision content. Screen Goo 2.0 beautifully reproduces these expanded color gamuts.

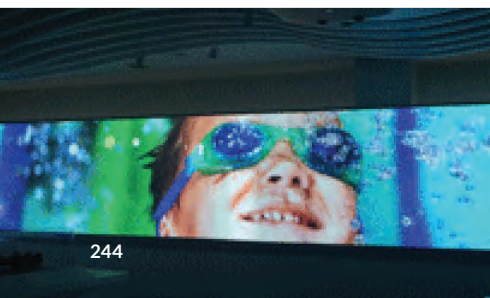

## SCREEN GOO 2.0 PRODUCTS



Screen Goo 2.0 should be applied using a roller or sprayer. Two thin coats of Goo should be applied onto a properly primed surface, allow 1 hour of dry time between coats. You can expect approximately 200 sq ft of coverage per gallon of Goo 2.0.

REFERENCE WHITE 2.0			HIGH CONTRAST 2.0		
100% White. Best suited for spaces with complete ambient lighting control.			Light Grey (85% White). Use in spaces with some control of ambient light levels.		
ITEM NUMBER	DESCRIPTION	PRICES	ITEM NUMBER	DESCRIPTION	PRICES
G0020001	Goo 2.0 Reference White 1L (appx 1 Qt)	175.00	G0020004	Goo 2.0 High Contrast 1L (appx 1 Qt)	175.00
G0020002	Goo 2.0 Reference White 1G	625.00	G0020005	Goo 2.0 High Contrast 1G	625.00
G0020003	Goo 2.0 Reference White 16L (appx 4.2G)	2,652.00	G0020006	Goo 2.0 High Contrast 16L (appx 4.2G)	2,652.00

MAX CONTRAST 2.0			ULTRA MAX CONTRAST 2.0		
Medium Grey (70% White). For areas with high ambient light levels.			Dark Grey (45% White). Best in spaces with high levels of ambient light.		
ITEM NUMBER	DESCRIPTION	PRICES	ITEM NUMBER	DESCRIPTION	PRICES
G0020007	Goo 2.0 Max Contrast 1L (appx 1 Qt)	175.00	G0020010	Goo 2.0 Ultra Max Contrast 1L (appx 1 Qt)	280.00
G0020008	Goo 2.0 Max Contrast 1G	625.00	G0020011	Goo 2.0 Ultra Max Contrast 1G	1040.00
G0020009	Goo 2.0 Max Contrast 16L (appx 4.2G)	2,652.00	G0020012	Goo 2.0 Ultra Max Contrast 16L (appx 4.2G)	4,400.00

SCREEN GOO PREMIER PRIMER 2.0		
100% acrylic primer that won't yellow over time the way typical PVA primers do, especially under the constant onslaught of UV rich projectors.		
ITEM NUMBER	DESCRIPTION	PRICES
G0020016	Goo 2.0 Premier Primer 1L (appx 1 Qt)	56.00
G0020017	Goo 2.0 Premier Primer 1G	200.00
G0020018	Goo 2.0 Premier Primer 16L (appx 4.2G)	825.00

SCREEN GOO TONAL REFERENCE CHART					
REFERENCE WHITE					HIGH CONTRAST
					MAX CONTRAST
					ULTRA MAX CONTRAST

## ADDITIONAL SCREEN GOO PRODUCTS

DESCRIPTION	ITEM NUMBER/PRICES				
	500ml	1L	2L	3.78L	16L
<b>Rear Projection Coating</b> is a semi-translucent diffusive coating for application to transparent substrates. Screen Goo Rear Projection coating should be sprayed only (not rolled or brushed) onto a clear substrate to create an excellent rear projection surface. No Reflective Coat is required.	GOOR0006 137.00	GOOR0001 209.00	GOOR0004 419.00	GOOR0005 735.00	GOOR0003 2,624.00
<b>Ultra Silver 3D Finish Coat</b> is a specially formulated coating designed to be used in the creation of non-depolarizing viewing surfaces for 3D projection applications. Use with Max Contrast Reflective Base Coat.	GOOU0011 160.00	GOOU0006 270.00	GOOU0009 500.00	GOOU0010 800.00	GOOU0008 3,300.00
<b>High Extinction Ultra Silver 3D Finish Coat</b> returns almost twice as much light as our standard Ultra Silver 3D coatings. High Extinction 3D features an even higher extinction ratio as our standard Ultra Silver 3D coating. Use with Max Contrast Reflective Base Coat.	GOOU0022 298.00	GOOU0023 573.00	GOOU0024 1,100.00	GOOU0025 1,993.00	GOOU0026 7,701.00
<b>Basic White</b> surface will produce a bright, detailed color-correct image, equally visible to every audience member. Available in White for fully light controlled environments and Grey for moderately lit rooms. No Finish Coat required.	GOOB0019 67.00	GOOB0020 129.00	GOOB0021 245.00	GOOB0022 443.00	GOOB0023 1,754.00
<b>Basic Grey</b> surface will produce a bright, detailed color-correct image, equally visible to every audience member. Available in White for fully light controlled environments and Grey for moderately lit rooms. No Finish Coat required.	GOOB0024 67.00	GOOB0025 129.00	GOOB0026 245.00	GOOB0027 443.00	GOOB0028 1,754.00
<b>Ultra Black Border Paint</b> is a non-reflective Black Border Goo for trimming your screen and to absorb any overlapping light from your projector.	GOOU0005 44.00	GOOU0001 86.00	GOOU0003 159.00	GOOU0004 253.00	N.A. N.A.

## SCREEN GOO ORIGINAL PRODUCTS

Final coverage of Screen Goo coatings is approximately 50 sq ft per litre. For example a 16ft x 9ft painted projection screen area (144 sq ft) would require 3 liters of Reflective Coat and 3 Liters of Finish Coat.

### A Screen Goo paint treatment is a two step process.

Each color system - Reference White, High Contrast, Max Contrast, and Ultra Max Contrast - requires a base Reflective Coat to be applied followed by a Finish Coat on top. Both the Reflective Base and Finish Top should be applied in two coats for best results. In each system, an optional +20 Finish Coat is available which can be used in place of the standard Finish Coat. The +20 Finish Coat results in an approximately 20% increase in reflectivity and should be used when maximum brightness is desired.

**Note:** The +20 Finish coat is used instead of the standard Finish Coat, not in addition to it.

Pricing available at [RoseBrand.com](http://RoseBrand.com)

## REFERENCE WHITE

A bright white finish. Best suited for rooms with complete light control - Use with projectors producing >12 ANSI Lumens per square foot of screen area.

PRODUCTS AVAILBLE		
Reflective Coat (Base)	Finish Coat (Top)	+20 Finish Coat (alt Top)

## MAX CONTRAST

A middle grey finish. Best suited for rooms with high ambient light levels - Use with projectors producing >35 ANSI Lumens per square foot of screen area.

PRODUCTS AVAILBLE		
Reflective Coat (Base)	Finish Coat (Top)	+20 Finish Coat (alt Top)

## HIGH CONTRAST

A light grey finish. Best suited for rooms with moderate ambient light levels - Use with projectors producing >25 ANSI Lumens per square foot of screen area.

PRODUCTS AVAILBLE		
Reflective Coat (Base)	Finish Coat (Top)	+20 Finish Coat (alt Top)

## ULTRA MAX CONTRAST

A medium grey finish. Uses Max Contrast Reflective Coat with Ultra Max Contrast Reflective Coat. Best suited for rooms with very high ambient light levels - Use with projectors producing >75 ANSI Lumens per square

PRODUCTS AVAILBLE		
Reflective Coat (Base)	Finish Coat (Top)	+20 Finish Coat (alt Top)

Fabrics  
Black Masking  
Custom Stage Curtains & Backdrops  
Custom Special Event Sewing  
Digital Printing  
LED Star Drops  
Pipe & Base  
Rentals  
Projection Materials  
Flooring  
Curtain Track  
Stage Equipment, FXs & Mirrors  
DMX Winches  
Scenery Props  
Shop & Production Supplies  
Tape  
Film & Video Supplies  
Index





Product: Massive Rose Brand 46'H x 224'W Compound Curve Projection Screen, Blackout Lining, Front Projection; Beyonce's World Humanitarian Day Performance; United Nations, General Assembly Hall; Projection Design: SuperUber; Services: Rose Brand Custom Manufacturing, Rigging & Installation; Photo: Victoria Oggioni



Product: Massive Rose Brand 46'H x 224'W Compound Curve Projection Screen, Blackout Lining, Front Projection; Beyonce's World Humanitarian Day Performance; United Nations, General Assembly Hall; Projection Design: SuperUber; Services: Rose Brand Custom Manufacturing, Rigging & Installation; Photo: Victoria Oggioni



Product: High Contrast Grey-120 Projection Screen; ©Feld Entertainment

Fabrics
Black Masking
Custom Stage Curtains & Backdrops
Custom Special Event Sewing
Digital Printing
LED Star Drops
Pipe & Base
Rentals
Projection Materials
Flooring
Curtain Track
Stage Equipment, FXs & Mirrors
DMX Winches
Scenery Props
Shop & Production Supplies
Tape
Film & Video Supplies
Index



# The Rose Brand Stretcher Frame System

This system is designed to fix extreme “hourglassing” and puckering often encountered with scrims, bobbinettes, vinyl projection screens, and muslin backdrops.

Features Include:

- Fast, easy attachment to batten
- Flies out with backdrop
- Adaptable to different sized backdrops
- Drops can attach using hook & loop, ties, or lacing methods
- Frame is black anodized aluminum extrusion
- Extrusion accepts standard strut hardware fitting
- Purchase components or purchase preconfigured unit
- Sleeved bottom pipe for smooth pockets

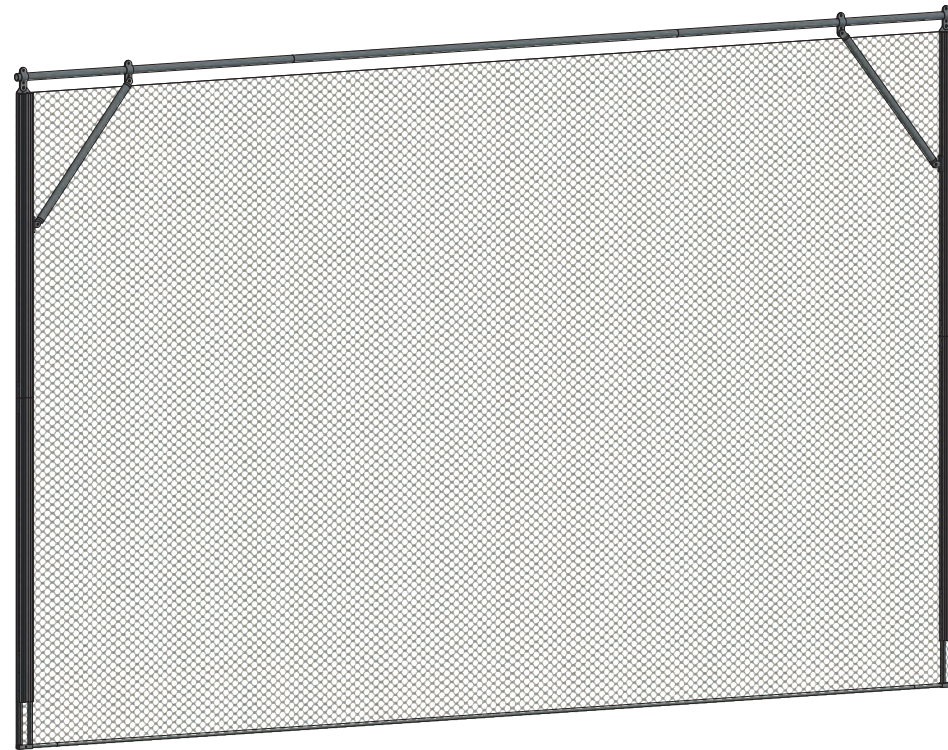

Rose Brand Stretcher Frame System

## What is “Hourglassing”?

“Hourglassing” is a problem that occurs when fabrics naturally stretch vertically causing the sides to pull in and in some cases puckering occurs. When you can’t hide this behind masking, or clamp and stretch offstage, *the Rose Brand Stretcher Frame System is the answer.*

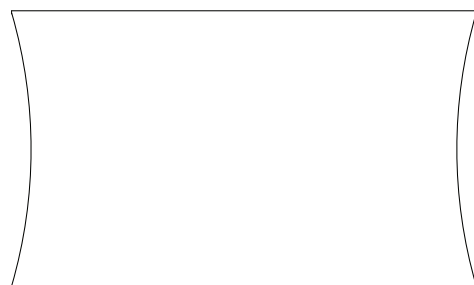

Fabrics that are prone to extreme “Hourglassing” include scrims, muslin backdrops, and the consistent headache, bobbinettes.

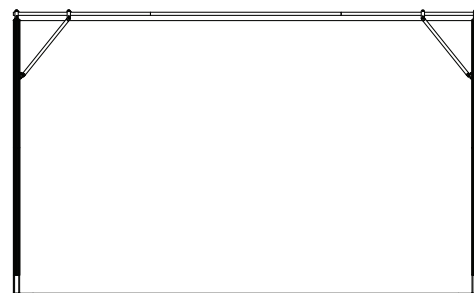

The Rose Brand Stretcher Frame System helps to keep soft goods taut and square. Great way to keep vinyl projection screens smooth.

## Components and Kit

Available as components or as a set that we can configure for your needs.

### THE ROSE BRAND STRETCHER FRAME SYSTEM COMPONENTS

	Price
<b>A</b> Frame- Mounting Bracket with Batten Clamp	40.00
<b>B</b> Frame Extrusion – 2" x 4" x 20'	475.00
<b>C</b> Frame Trombone	145.00
<b>D</b> Frame Diagonal Support	100.00
<b>E</b> Frame Splice Set	75.00
<b>F</b> Bottom Pipe with internal sleeves – ½" sch 40 - 10' length	60.00

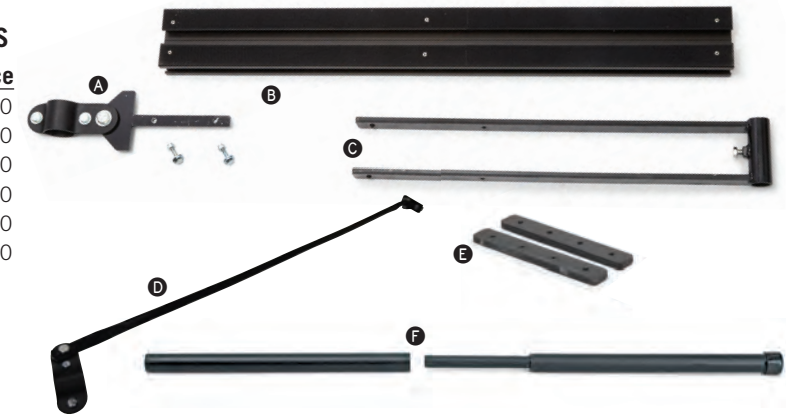

### THE ROSE BRAND STRETCHER FRAME SYSTEM KIT

Height	Width up to 10'	Width 11' to 20'	Width 21' to 30'	Width 31' to 40'	Width Price for every additional 10'*
up to 10'	1,245.00	1,305.00	1,365.00	1,425.00	add 60.00
11' to 20'	1,830.00	1,890.00	1,950.00	2,010.00	add 60.00
21' to 30'	2,555.00	2,615.00	2,675.00	2,735.00	add 60.00
31' to 40'	3,230.00	3,290.00	3,350.00	3,410.00	add 60.00

Pricing on this chart is for stretcher frames that are configured by Rose Brand to your soft goods dimensions.

Units include:

- Components cut to size.
- Pre-drilled for assembly.
- Parts ship preassembled when practical.
- Hook and loop fastener adhered, then riveted on one 4" face.
- Top Pipes are NOT included – it is assumed frames are mounted on customer supplied top pipe.

While you can mount soft goods to the face of the frame using hook and loop fastener, standard practice is to wrap the frame and attach to the back side. This technique requires soft goods to be 8" wider than the finished width. When ordering, please note if you do not want the hook and loop fastener.

\*Call a Rose Brand Sales representative if you require quote for width over 80'.

## Curtain Finish Details



Hook and Loop Mount



Side Ties



Side Lacing



Bottom Detail



# Flooring

- Stage, Event & Dance Floors .....252
- Floor Care .....261
- Event Carpet .....262
- Lux Event Carpet .....264

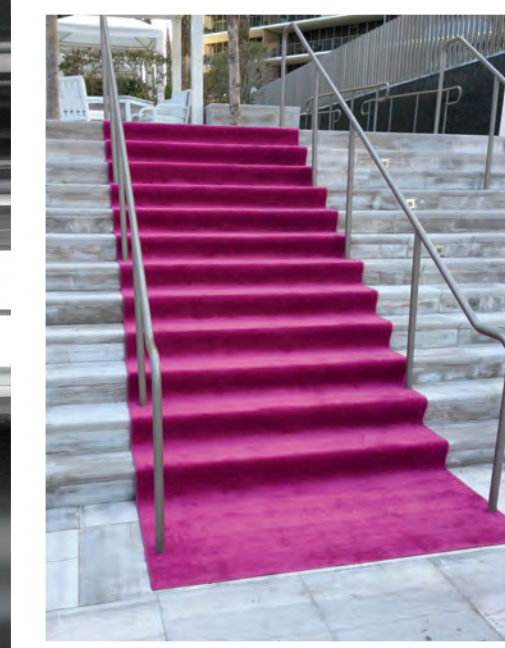
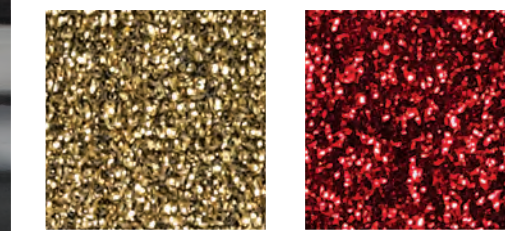
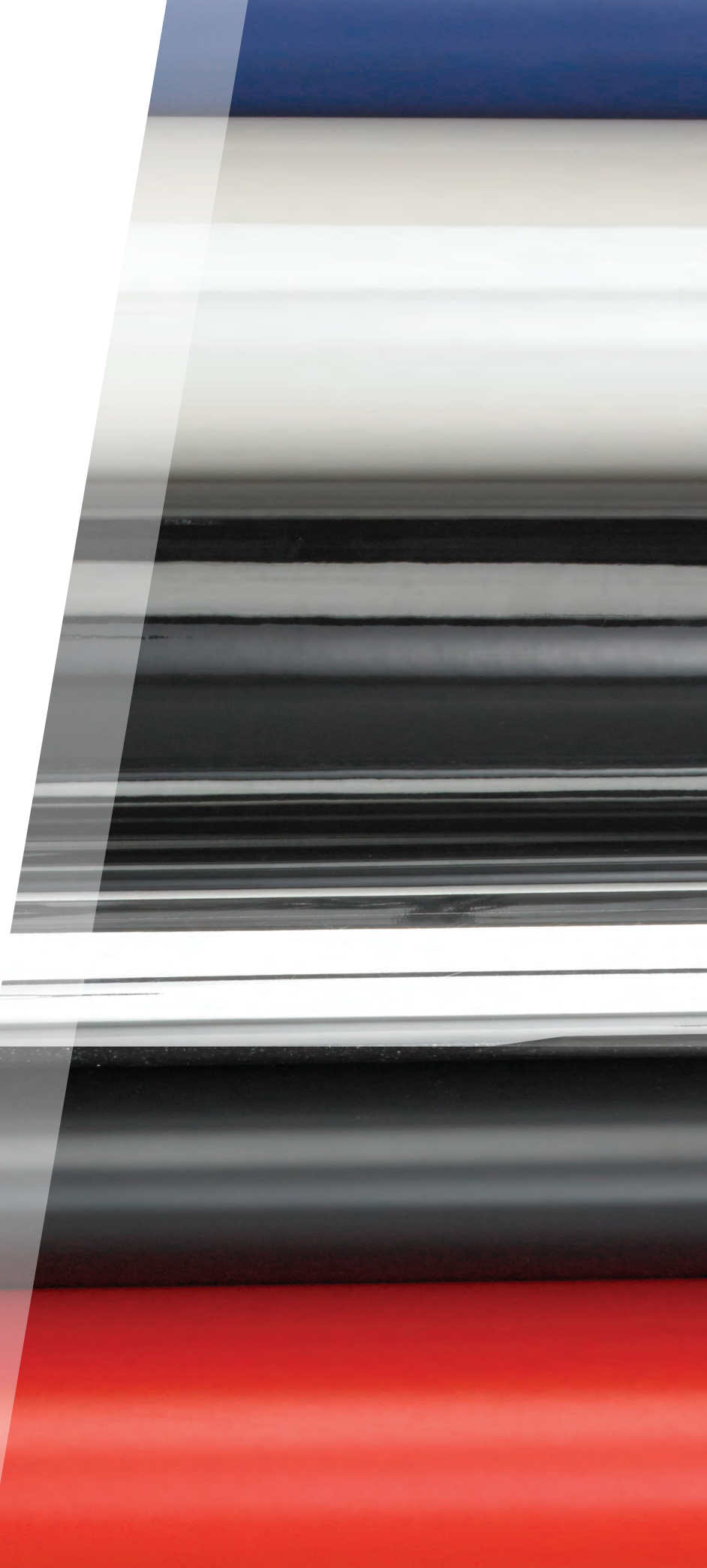

- Fabrics
- Black Masking
- Custom Stage Curtains & Backdrops
- Custom Special Event Sewing
- Digital Printing
- LED Star Drops
- Pipe & Base
- Rentals
- Projection Materials
- Flooring**
- Curtain Track
- Stage Equipment, FXs & Mirrors
- DMX Winches
- Scenery Props
- Shop & Production Supplies
- Tape
- Film & Video Supplies
- Index



# Stage, Event & Dance Floors

## EXPO™

A lightweight, affordable covering for events, runways and budget-conscious productions.

For catwalks, runways, live events and stages, Expo Floors are ideal – the perfect combination of quality and cost consideration. Lightweight yet durable, this 1.3mm covering is easy to roll out and lays out for a fast load-in. Stock black, white or grey floors will work for most events, or custom colors are available when a show floor with more pop is needed.

### FEATURES/BENEFITS:

- Lightweight, affordable covering
- Lay flat, easy installation
- Colors available upon request
- Temporary installation with tape or adhesives

### RECOMMENDED FOR:

- Runway and catwalks
- Special event stages
- Live events
- Trade shows

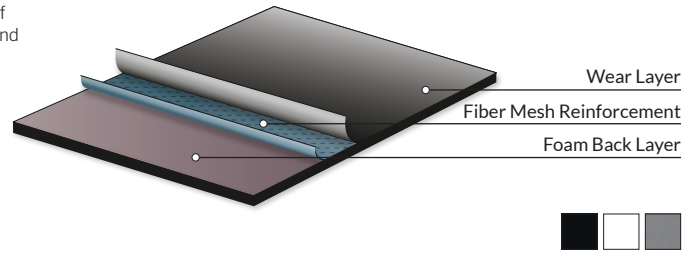

### SPECIFICATIONS

COLOR/ITEM NUMBER	FINISH	EMBOSS	THICKNESS	WEAR LAYER	WIDTH	ROLL LENGTH	WEIGHT	PRICE/LINEAR FT	PRICE/ROLL
Black - FLOE0003	Matte	Smooth	1.3 mm (0.05 in)	0.35 mm	2.0 m (78 in)	25 m (82 ft)	45 Kg (99 lbs) / roll 0.2 lbs / sq ft	12.00	856.08
White - FLOE0004									
Grey - FLOE0005									

## BALLARE™

An all-purpose floor perfect for events, stage and dance.

Ballare is an all-purpose floor suited to meet the widest variety of needs in entertainment production. A durable matte floor available in a variety of colors, Ballare is easy to install for special events, durable enough for many stage applications and provides a good all-around surface for dance studios and rehearsal spaces. Also available in a high-gloss finish for even greater visual impact!

### FEATURES/BENEFITS:

- All purpose floor for a variety of environments
- Lay flat, easy installation
- Available in colors and gloss finishes
- Temporary installation with tape or adhesives

### RECOMMENDED FOR:

- Special events
- Theatre
- Trade shows

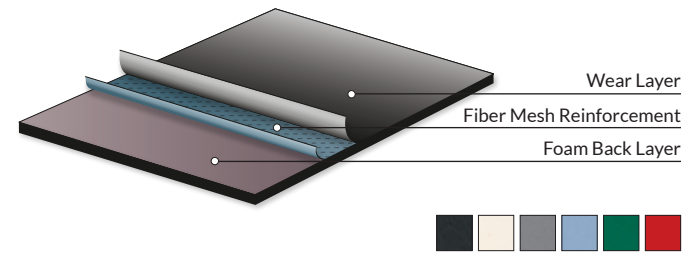

### SPECIFICATIONS

COLOR/ITEM NUMBER	FINISH	EMBOSS	THICKNESS	WEAR LAYER	WIDTH	ROLL LENGTH	WEIGHT	PRICE/LINEAR FT	PRICE/ROLL
Black - FLOB0001	Matte	Smooth	2.0 mm (0.08 in)	0.35 mm	2.0 m (78 in)	25 m (82 ft)	65 Kg (143 lbs) / roll 0.27 lbs / sq ft	14.50	1,004.50
White - FLOB0008									
Grey - FLOB0004									
Blue - FLOB0007									
Green - FLOB0003									
Red - FLOB0006									

## DURA™

A hard-wearing, easy roll out durable floor for temporary or permanent installation.

Dura is a floor to make touring easy. Its finely textured surface is suitable for a wide variety of traffic including live performance, rehearsals, dance and auditorium use. Dura is rugged yet amazingly pliable and is interleaved with a glass fiber reinforcement layer for complete dimensional stability. The floor's overall construction is 2mm thick and has an incredibly durable 0.7mm wear layer. Dura is easy to roll out over stage decks or can be permanently adhered to platforms or sub floors.

### FEATURES/BENEFITS:

- Heavy duty, durable floor
- Flexible, lay flat, easy installation
- Subtle texture and slight cushioning
- Permanent or temporary installation

### RECOMMENDED FOR:

- Stages
- Dance studios
- Multi-purpose rooms
- Rehearsal halls and touring decks

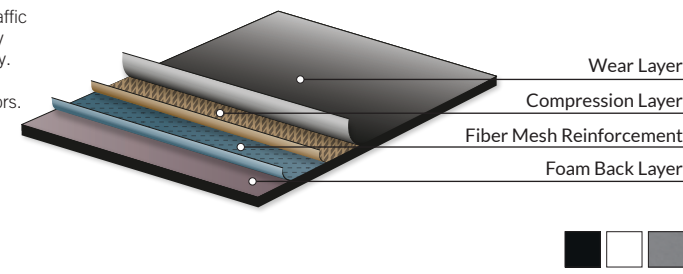

### SPECIFICATIONS

COLOR/ITEM NUMBER	FINISH	EMBOSS	THICKNESS	WEAR LAYER	WIDTH	ROLL LENGTH	WEIGHT	PRICE/LINEAR FT	PRICE/ROLL
Black - FLOD0016	Flat	Suede	2 mm (0.08 in)	0.7 mm	2.0 m (78 in)	20 m (65 ft)	108 Kg (238 lbs) / roll 0.6 lbs / sq ft	15.50	876.85
White - FLOD0017									
Grey - FLOD0018									

# Stage, Event & Dance Floors

## GLIDE™ NEW

Our best quality performance floor for stage and dance

Glide combines an ideal surface, maximum durability and easy installation into one premium floor. Its matte, smooth 0.7mm wear layer will withstand years of performance and stage traffic while the supple hand of the roll insures fast lay-flat installation. Like all Rose Brand floors, Glide is constructed around a fiber mesh reinforcement layer which provides dimensional stability to prevent shrinking and expansion due to temperature fluctuations. For temporary or permanent installation.

### FEATURES/BENEFITS:

- Ideal, durable surface for all types of performance
- Lay flat, easy installation. Matte finish
- Tight compression layer to absorb hard impacts
- Permanent or temporary installation

### RECOMMENDED FOR:

- Performance stages
- Dance Studios and Rehearsal Halls
- Touring floors

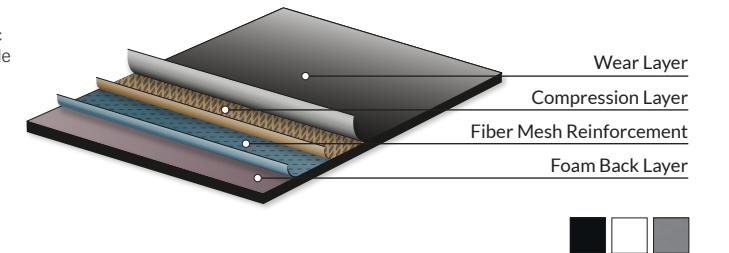

### SPECIFICATIONS

COLOR/ITEM NUMBER	FINISH	EMBOSS	THICKNESS	WEAR LAYER	WIDTH	ROLL LENGTH	WEIGHT	PRICE/LINEAR FT	PRICE/ROLL
Black - FLOG0001	Matte	Smooth	2 mm (0.08 in)	0.7 mm	2.0 m (78 in)	20 m (65 ft)	108 Kg (238 lbs) / roll 0.6 lbs / sq ft	17.50	1,023.75
White - FLOG0002									
Grey - FLOG0003									

## TEATRO™

A superior, heavy duty, reversible floor with dimensional stability for stage, touring or dance.

Teatro takes the classic reversible floor to new standards in performance. Two homogeneous vinyl wear surfaces are laminated around a fiber mesh reinforcement layer for maximum dimensional stability no matter how many times the floor is rolled or reversed. A smooth finish in black/white or black/grey is just right for dance, stage performance, tradeshow or event floors. Teatro is a superior reversible floor in every way.

### FEATURES/BENEFITS:

- Reversible surface for different design needs
- Durable for high traffic environments
- Lay flat, easy installation
- Suitable for temporary or permanent installation

### RECOMMENDED FOR:

- Stage floors
- Rehearsal halls
- Touring decks
- Ballet, modern, jazz, and hip-hop

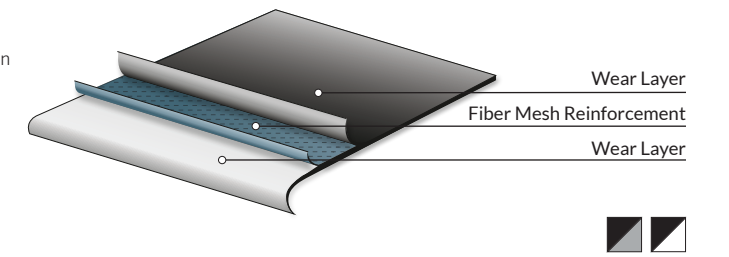

### SPECIFICATIONS

COLOR/ITEM NUMBER	FINISH	EMBOSS	THICKNESS	WEAR LAYER	WIDTH	ROLL LENGTH	WEIGHT	PRICE/LINEAR FT	PRICE/ROLL
Black / Grey - FLOT0001	Matte	Smooth	1.7 mm (0.067 in)	0.7 mm x 2	2.0 m (78 in)	20 m (65 ft)	84 Kg (185 lbs) / roll 0.4 lbs / sq ft	16.50	933.40
Black / White - FLOT0002									



Product: Dura Floor; Solomon R. Guggenheim Museum; Falls the Shadow Exhibition; Photo: Louis Peter

- Fabrics
- Black Masking
- Custom Stage Curtains & Backdrops
- Custom Special Event Sewing
- Digital Printing
- LED Star Drops
- Pipe & Base
- Rentals
- Projection Materials
- Flooring
- Curtain Track
- Stage Equipment, FXs & Mirrors
- DMX Winches
- Scenery Props
- Shop & Production Supplies
- Tape
- Film & Video Supplies
- Index



## Stage, Event & Dance Floors

### DOLCE™

**A long life, gently cushioned floor for stage, rehearsal rooms, expo or dance - anywhere durability and comfort are key requirements.**

Gentle cushioning is the trademark of Dolce floors. Combined with its hard wearing surface, this makes Dolce the right choice where extra protection and long life are the primary concerns. It can be permanently installed and has a light embossed surface texture for additional slip resistance. The overall thickness is 2.5mm constructed of a 0.7mm wear layer plus glass-fiber reinforcement layer and cushioning. Multi-purpose venues, studios and deck covers will all benefit from installing Dolce floors.

#### FEATURES/BENEFITS:

- Cushioned under layer for comfort and slip control
- Flexible, lay flat, easy installation
- Subtle texture and slight cushioning
- Permanent or temporary installation

#### RECOMMENDED FOR:

- Rehearsal halls
- Stages
- Dance studios
- Multi-purpose rooms

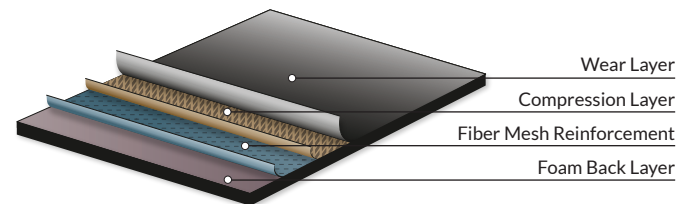

Wear Layer  
Compression Layer  
Fiber Mesh Reinforcement  
Foam Back Layer



#### SPECIFICATIONS

COLOR/ITEM NUMBER	FINISH	EMBOSS	THICKNESS	WEAR LAYER	WIDTH	ROLL LENGTH	WEIGHT	PRICE/LINEAR FT	PRICE/ROLL
Black - FLOD0019 Grey - FLOD0020	Flat	Suede	2.5 mm (0.1 in)	0.7 mm	2.0 m (78 in)	20 m (65 ft)	140 Kg (308 lbs) / roll 0.7 lbs / sq ft	19.50	1,103.05

### DOLCE PLUS™

**Deep cushioned floor for dance studios and exhibitions. Gentle on feet and joints and durable enough for a long life.**

Gentle cushioning is the trademark of Dolce floors. Dolce Plus offers maximum comfort and safety from a plush 6mm thick cushioning layer. Combined with its hard wearing surface, this makes Dolce Plus the right choice in studios and stages which are used for high impact performances. It can be permanently installed and has a light embossed surface texture for additional slip resistance. The overall thickness is 6mm constructed of a 0.7mm wear layer plus glass-fiber reinforcement layer and cushioning. Despite its thicker construction, Dolce Plus rolls out and lays flat quickly for easy installation. Multi-purpose venues, dance studios and exhibition stages will all benefit from installing Dolce Plus floors.

#### FEATURES/BENEFITS:

- Thick cushioning for comfort and safety
- Heavy duty, durable floor
- Flexible, lay flat, easy installation
- Subtle texture and slight cushioning
- Permanent or temporary installation

#### RECOMMENDED FOR:

- Exhibitions
- Rehearsal halls
- Stages
- Dance studios

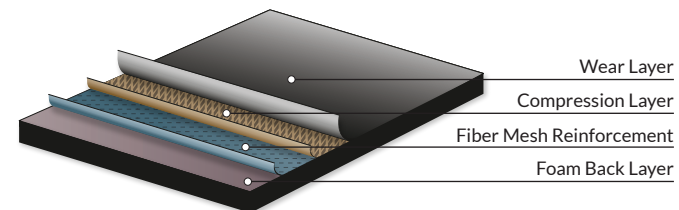

Wear Layer  
Compression Layer  
Fiber Mesh Reinforcement  
Foam Back Layer



#### SPECIFICATIONS

COLOR/ITEM NUMBER	FINISH	EMBOSS	THICKNESS	WEAR LAYER	WIDTH	ROLL LENGTH	WEIGHT	PRICE/LINEAR FT	PRICE/ROLL
Black - FLOD0021 Grey - FLOD0022	Flat	Suede	6.0 mm (0.24 in)	0.7 mm	2.0 m (78 in)	20 m (65 ft)	105 Kg (231 lbs) / roll 0.7 lbs / sq ft	21.95	1,241.50

### HI-SHINE

**Glass-like gloss for the most demanding special events.**

Hi-Shine is the ideal floor for television, concerts, display and exhibitions, as well as for use within theaters and for operatic productions. It rolls out easily and provides a breathtaking glossy finish.

Hi-Shine adds luster to any occasion. It's specified for loose-lay installation and its special high-gloss surface is superior to urethane for scratch-resistance, providing a shiny, reflective surface.

Hi-Shine is a striking choice for opera, television sets, high-profile entertainment, fashion shows, product launches, parties, exhibitions, window displays, artistic use, etc. It's purchased by a wide range of production companies and utilized on major TV shows and movies.



#### SPECIFICATIONS

COLOR/ITEM NUMBER	FINISH	EMBOSS	THICKNESS	WEAR LAYER	WIDTH	ROLL LENGTH	WEIGHT	PRICE/LINEAR FT	PRICE/ROLL
Red - FLOH0007	Ultra Glossy	Smooth	1.5 mm (0.06 in)	.3 mm	1.5 m (59 in)	30 m (98'4")	95.5 Kg (210 lbs) / roll	N/A	1,617.70
Black - FLOH0005 White - FLOH0008 Blue - FLOH0006	Ultra Glossy	Smooth	1.5 mm (0.06 in)	.3 mm	1.5 m (59 in)	20 m (65'7")	66.2 Kg (146 lbs) / roll	N/A	1,080.00

## Stage, Event & Dance Floors

### EXPO GLOSS™



**Best value in gloss floor for special events.**

For catwalks, runways, live events and stages, Expo Gloss Floors are ideal – the perfect combination of quality and cost consideration. Lightweight yet durable, this 1.3mm covering is easy to roll out and lays out for a fast load-in. Stock black, white or grey floors will work for most events, or custom colors are available when a show floor with more pop is needed.

#### FEATURES/BENEFITS:

- Lightweight, affordable covering
- Lay flat, easy installation
- Colors available upon request
- Temporary installation with tape or adhesives

#### RECOMMENDED FOR:

- Runway and catwalks
- Special event stages
- Live events
- Trade shows

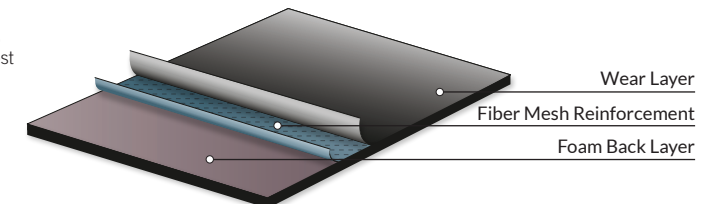

Wear Layer  
Fiber Mesh Reinforcement  
Foam Back Layer



#### SPECIFICATIONS

COLOR/ITEM NUMBER	FINISH	EMBOSS	THICKNESS	WEAR LAYER	WIDTH	ROLL LENGTH	WEIGHT	PRICE/LINEAR FT	PRICE/ROLL
Gloss Black - FLOE0006 Gloss White - FLOE0007 Gloss Grey - FLOE0008	Matte	Smooth	1.3 mm (0.05 in)	0.35 mm	2.0 m (78 in)	25 m (82 ft)	45 Kg (99 lbs) / roll 0.2 lbs / sq ft	17.50	1,127.50

### GLOSS BALLARE

**A high gloss sheen to add punch to any special event plus the strength to handle the traffic.**

Gloss Ballare offers both a durable all-purpose floor construction and a special event quality finish. Available in classic Black or White as well as Red and Blue.

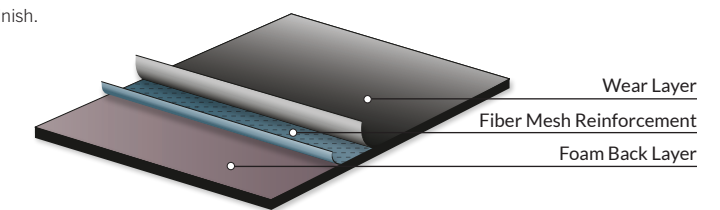

Wear Layer  
Fiber Mesh Reinforcement  
Foam Back Layer



#### SPECIFICATIONS

COLOR/ITEM NUMBER	FINISH	EMBOSS	THICKNESS	WEAR LAYER	WIDTH	ROLL LENGTH	WEIGHT	PRICE/LINEAR FT	PRICE/ROLL
Black - FLOB0020 White - FLOB0021 Red - FLOB0022 Blue - FLOB0023	Glossy	Smooth	2 mm (0.08 in)	.35 mm	1.5 m (59 in)	25 m (82 ft)	55 Kg (121 lbs) / roll	17.25	1,225.00

### MIRROR FLOOR

**Brilliant reflective silver mirror surface for special effects, runways and live events.**

Mirror Floor creates a stunning first impression for any event. Exercise careful handling to keep the finish pristine until opening night. Not intended for long term use as foot traffic will eventually mar and scuff the reflection.



#### SPECIFICATIONS

COLOR/ITEM NUMBER	FINISH	EMBOSS	THICKNESS	WEAR LAYER	WIDTH	ROLL LENGTH	WEIGHT	PRICE/LINEAR FT	PRICE/ROLL
Silver - FLOM0003	Mirror	Smooth	1.25 mm (0.05 in)	N/A	1.4 m (55 in)	25 m (82 ft)	50 Kg (110 lbs) / roll	28.00	1,850.00
Gold - FLOM0004	Mirror	Smooth	1.5 mm (0.06 in)	N/A	1.5 m (59 in)	20 m (65 ft)	60.3 Kg (132 lbs) / roll	28.00	1,638.00



**ROSCO REVERSIBLE**

**Dance floor is reversible with black on one side and your choice of white or grey on the other.**

This durable all-purpose floor is best used in permanent or semi-permanent installations in studios, multi-purpose rooms and showrooms. Performance Floor's durability and abrasion resistance allows it to stand up wherever traffic is heaviest while still offering an excellent surface for all forms of dance.



SPECIFICATIONS									
COLOR/ITEM NUMBER	FINISH	EMBOSS	THICKNESS	WEAR LAYER	WIDTH	ROLL LENGTH	WEIGHT	PRICE/LINEAR FT	PRICE/ROLL
Black / White - FLOD0004 Black / Grey - FLOD0003	Matte	Smooth	1.25 mm (0.05 in)	.5 mm	1.6 m (63 in)	40 m (131.3 ft)	116 Kg (255 lbs) / roll	14.25	1,750.00

**ROSCO ADAGIO**

**Professional dance surface for wide range of styles and installations.**

If versatility in usage is your primary concern, Adagio should be your first choice. It is recommended for tap but its non-reflective, controlled slip vinyl surface makes it equally successful as a ballet, modern and jazz floor. Because it is dimensionally stable it can be permanently installed using Rosco adhesives for long term use.

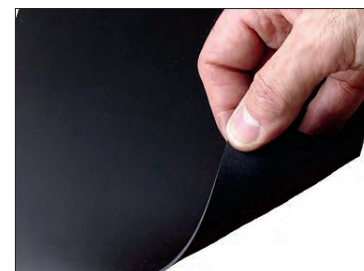

SPECIFICATIONS									
COLOR/ITEM NUMBER	FINISH	EMBOSS	THICKNESS	WEAR LAYER	WIDTH	ROLL LENGTH	WEIGHT	PRICE/LINEAR FT	PRICE/ROLL
Black - FLOA0001 Grey - FLOA0002	Matte	Silk	1.5 mm (0.06 in)	.3 mm	1.6 m (63 in)	31 m (101.71 ft)	113 Kg (250 lbs) / roll	19.25	1,825.00

**ROSCO ADAGIO TOUR**

**Lightweight version of Rosco's popular Adagio Floor.**

Adagio Tour is uniquely suited to those who need a tough, lightweight floor for percussive dance styles. Tour has been specially designed to lay flat quickly and provide a surface with terrific tap sound. The surface is also excellent for all other dance forms including ballet, modern, Irish and jazz. Adagio Tour weighs only 1.6 lbs. per linear foot and provides a matte, non-reflective surface that is ideal in all performance venues. Despite the tough surface, Adagio Tour is very flexible, assuring years of carefree rolling and re-rolling.



SPECIFICATIONS									
COLOR/ITEM NUMBER	FINISH	EMBOSS	THICKNESS	WEAR LAYER	WIDTH	ROLL LENGTH	WEIGHT	PRICE/LINEAR FT	PRICE/ROLL
Black - FLOA0003 Grey - FLOA0004	Matte	Silk	1 mm (0.04 in)	.3 mm	1.6 m (63 in)	101.71 ft	75 Kg (165 lbs) / roll	14.50	1,380.00

**PERFORMANCE FLOOR**

**For extreme durability in multi-purpose environments.**

This durable all-purpose floor is best used in permanent or semi-permanent installations in studios, multi-purpose rooms and showrooms. Performance Floor's durability and abrasion resistance allows it to stand up wherever traffic is heaviest while still offering an excellent surface for all forms of dance.



SPECIFICATIONS									
COLOR/ITEM NUMBER	FINISH	EMBOSS	THICKNESS	WEAR LAYER	WIDTH	ROLL LENGTH	WEIGHT	PRICE/LINEAR FT	PRICE/ROLL
Black - FLOP0005 Dark Grey - FLOP0006 Light Grey - FLOP0007 White - FLOP0008	Matte	Smooth	2.5 mm (0.10 in)	.7 mm	1.8 m (72 in)	18.25 m (60')	127 Kg (280 lbs) / roll	N/A	1,943.30

**SHOW FLOOR**

**Heavy, high gloss stage floor for events and exhibitions.**

This super glossy floor is perfect for special events, commercials and fashion promotions. This high shine floor adds just the right sparkle to any venue. Show Floor is not designed for heavy traffic or permanent installation.



SPECIFICATIONS									
COLOR/ITEM NUMBER	FINISH	EMBOSS	THICKNESS	WEAR LAYER	WIDTH	ROLL LENGTH	WEIGHT	PRICE/LINEAR FT	PRICE/ROLL
Black - FLOS0048 White - FLOS0049 Red - FLOS0050	Glossy	Smooth	2 mm (0.08 in)	.3 mm	1.8 m (72 in)	18.25 m (60')	125 Kg (275 lbs.) / roll	N/A	1,662.45

**STUDIO FLOOR**

**Matte, non reflective surface in a heavy duty floor.**

This ultra matte, black vinyl floor is ideal as a staging floor for ballet, theatre or any application where a light absorbing surface is needed. Studio Floor is not designed for heavy traffic areas. The floor may be installed permanently or semi-permanently.



SPECIFICATIONS									
COLOR/ITEM NUMBER	FINISH	EMBOSS	THICKNESS	WEAR LAYER	WIDTH	ROLL LENGTH	WEIGHT	PRICE/LINEAR FT	PRICE/ROLL
Black - FLOS0051	Ultra Matte	Smooth	2 mm (0.08 in)	.3 mm	1.8 m (72 in)	18.25 m (60')	113 Kg (250 lbs.) / roll	N/A	1,748.25



## Stage, Event & Dance Floors

### CHROMA KEY

**Reversible Blue and Green surfaces for digital compositions and other special effects.**

Rosco's Chroma Key Floor solves the long-standing problem of repainting your studio floor for every shoot. Chroma Key Blue on one side and Chroma Key Green on the other make Chroma Floor an ideal addition to any studio. Precise color matching with Rosco Chroma Key paints allows for seamless compositions.



#### SPECIFICATIONS

COLOR/ITEM NUMBER	FINISH	EMBOSS	THICKNESS	WEAR LAYER	WIDTH	ROLL LENGTH	WEIGHT	PRICE/LINEAR FT	PRICE/ROLL
CKG/CKB - FLOD0006	Matte	Smooth	1.25 mm (0.05 in)	.5 mm	1.6 m (63 in)	40 m (131.3')	113 Kg (250 lbs) / roll	21.95	1,685.00

### ROSCO TILES

**High density tiles for broadcast studios that can take the weight of heavy camera pedestals. Fast lay down and take up for easy set change.**

Rosco Tiles were originally designed as rugged, hard wearing floors for video production facilities and television studios. They lay flat for temporary, as well as permanent studio installations and can stand up to camera dollies. The dance world has discovered they make terrific practice tiles for tap and Irish dance! The 3' x 3' squares are an ideal size for practice at home. They weigh just 12 lbs. each making them easy to pick up and store away when rehearsal is done.

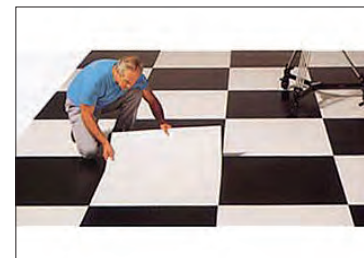

Rosco Tiles are available in Black, Grey and White.

#### SPECIFICATIONS

COLOR/ITEM NUMBER	FINISH	EMBOSS	THICKNESS	WEAR LAYER	WIDTH	ROLL LENGTH	WEIGHT	PRICE/TILE
Black - TILE0004 White - TILE0005 Grey - TILE0006	Low Sheen	Smooth	3 mm (0.125 in)	N/A	3' x 3'	N/A	5.5 Kg (12 lbs) / tile'	48.75

### IMPACT™ CLEAR FLOOR

**Durable clear vinyl floor for LED stages or anywhere a clear protective floor is needed.**

Impact™ Clear floor is a tough clear vinyl surface perfect for use on plexiglass-topped LED stages, providing a much improved, slip resistant surface over the hard acrylic. Easy to roll out over finished decks or apply directly to each platform section. Hard wearing for long life but easy and to replace when the decks need to be refreshed. The slightly embossed top surface gives it a matte finish to resist harsh glares and reflections and provides a subtle diffusion for the LEDs. Available in 120" wide x 50' roll or 60" x 50' rolls. Cut footage not available.



#### SPECIFICATIONS

COLOR/ITEM NUMBER	FINISH	EMBOSS	THICKNESS	WEAR LAYER	WIDTH	ROLL LENGTH	WEIGHT	PRICE
FLOI0002	Matte	Grain	1.9 mm (0.075 in)	N/A	60 in	50 ft	160 lbs / roll	1,300.00
FLOI0001					120 in	50 ft	320 lbs / roll	2,600.00



Products: Printed Ballare Floor; Rain Curtains; Custom Curved Track and Installation Services; The Let Go by Nick Cave at Park Avenue Armory, June 2018; Photo by James Prinz Photography. Courtesy of the artist and Jack Shainman Gallery, New York.

- Fabrics
- Black Masking
- Custom Stage Curtains & Backdrops
- Custom Special Event Sewing
- Digital Printing
- LED Star Drops
- Pipe & Base
- Rentals
- Projection Materials
- Flooring**
- Curtain Track
- Stage Equipment, FXs & Mirrors
- DMX Winches
- Scenery Props
- Shop & Production Supplies
- Tape
- Film & Video Supplies
- Index



## Stage, Event & Dance Floors and Accessories

FLOOR CARE			
PRODUCT	SPECIFICATIONS	QUANTITY	PRICE
<b>ROSCO ALL PURPOSE FLOOR CLEANER</b>	Designed for the regular cleaning of all Rosco floors. Biodegradable, phosphate-free and will not leave residue.	1 Liter 1 Gallon	15.50 37.55
<b>ROSCO HEAVY-DUTY FLOOR CLEANSER</b>	For stripping, deep cleansing and routine maintenance of normal finish vinyl dance floors. Not recommended for use with Show Floor.	1 Liter 1 Gallon	15.50 37.55
<b>SLIP NOMOR 2000C</b>	A super concentrated formula, one gallon makes up to 20 gallons of application solution. One application covers approx. 1,000 sq. ft.	1 Gallon	82.00
<b>PROCLEAN NS CLEANSER</b>	This super-concentrated floor cleaner used at least once a week will keep your floors sparkling. Use 3 ounces of concentrated cleaner for every 1000 sq. ft.; a gallon lasts for a year. Non-toxic.	1 Gallon	63.50
<b>STREET SHOE FLOOR FINISH</b>	Commercial Wood Floor Finish with XL Catalyst is a water based system formulated especially for high traffic wood floors. It provides a clear finish that remains unmatched in performance and durability. Apply to bare or stained wood and painted floors. Coverage is 550 -700 ft <sup>2</sup> /gal. Dry time is 2-3 hrs between coats. Gloss and Super Matte.	1 Gallon	110.25



### THE ROSE BRAND FLOOR STORAGE CART (ROLL PIPE SOLD SEPARATELY)

The Rose Brand Floor Storage Cart holds up to six 2m (78") wide rolls of stage flooring for storage and transport within your venue. With sturdy 4" locking casters and sized to fit through single doors the Floor Storage Cart keeps floor rolls suspended to avoid compression marks and damage when not in use. Fully adjustable arms accommodate rolls up to 16" diameters. Use simple 1-1/4" pipe down the center to suspend each roll, or rewind the floor onto 3" PVC pipe for more durability. Packs flat for economical shipping and assembles quickly and easily. Pipe and PVC not included. Not intended for touring



### FLOOR CART DUST COVER - IFR BLACK

A black "toaster cover" dust cover for your Floor Storage Cart. Made from sturdy IFR Avora Plus, this cover will keep back stage dust and debris off of your stage floor rolls. Stretch Ties at the bottom fasten the cover to the frame.

SPECIFICATIONS				
ITEM NUMBER	PRODUCT	DIMENSIONS	WEIGHT	PRICE
CART0001	<b>THE ROSE BRAND FLOORS STORAGE CART</b>	32" x 88" x 54"	210 lbs	1,495.00
CART0002	<b>FLOOR CART DUST COVER</b>	35" x 89" x 52"		79.00
CART0003	<b>1 1/4" ROLL PIPES (SET OF 2)</b>	2 @ 1-1/4" x 98"	18.5 lbs each	250.00

## Floor Care

FLOOR COMPARISON CHART - ATTRIBUTES										
		● Ideally Suited ● Acceptable								
FLOOR	DESCRIPTION	STAGE	DANCE	SPECIAL EVENTS	Durable for high traffic & heavy loads	Lay flat and easy installation	Light weight and portable	Cushioned for comfort and safety	Available in colors	Suitable for permanent installation
<b>Expo</b>	A light-weight affordable covering for events, runways and budget conscious productions.	●		●		●	●		●	
<b>Dura</b>	A hard wearing, easy roll out and durable floor for temporary or permanent installation.	●	●	●	●	●	●	●		●
<b>Ballare</b>	An all-purpose floor perfect for events, stage and dance.	●	●	●	●	●	●	●	●	●
<b>Teatro</b>	A superior, heavy duty, reversible floor with dimensional stability for stage, touring or dance.	●	●	●	●	●	●			●
<b>NEW Glide</b>	Our best quality performance floor for stage and dance	●	●	●	●	●	●	●		●
<b>Dolce</b>	A long life, gently cushioned floor for stage, rehearsal rooms, expo or dance - anywhere long life and comfort are the requirements.	●	●	●	●	●		●		●
<b>Dolce Plus</b>	Deep cushioned floor for dance studios and exhibitions. Gentle on feet and joints and durable enough for a long life.	●	●	●	●	●		●		●
<b>Gloss Ballare</b>	A high gloss sheen to add punch to any special event plus the strength to handle the traffic.	●	●	●	●	●	●	●	●	
<b>NEW Expo Gloss</b>	Best value in gloss floor for special events.	●		●		●	●		●	
<b>Mirror Floor</b>	Brilliant reflective silver mirror surface for special effects, runways and live events.	●		●		●	●			
<b>Rosco Reversible</b>	Dance floor is reversible with black on one side and your choice of white or grey on the other.	●	●	●		●	●			
<b>Rosco Adagio</b>	Professional dance surface for wide range of styles and installations.	●	●	●	●	●	●			●
<b>Rosco Adagio Tour</b>	Lightweight version of Rosco's popular Adagio floor.	●	●	●	●	●	●			●
<b>Performance Floor</b>	For extreme durability in multi-purpose environments.	●	●	●	●	●				●
<b>Show Floor</b>	Heavy, high gloss floor for events and exhibitions.	●	●	●	●	●			●	
<b>Studio Floor</b>	Matte, non reflective surface in a heavy duty floor.	●	●	●	●	●			●	●
<b>Hi-Shine</b>	Glass-like gloss for the most demanding special events.	●	●	●		●	●			
<b>Rosco Chroma Key</b>	Reversible Blue and Green surfaces for digital compositions and other special effects.	●	●	●		●	●			
<b>Rosco Tiles</b>	High density tiles for broadcast studios that can take the weight of heavy camera pedestals. Fast lay down and take up for easy set change.	●	●	●	●	●	●			●
<b>Impact™ Clear</b>	Durable clear vinyl floor for LED stages or anywhere a clear protective floor is needed.	●		●	●	●	●			●



# Event Carpet

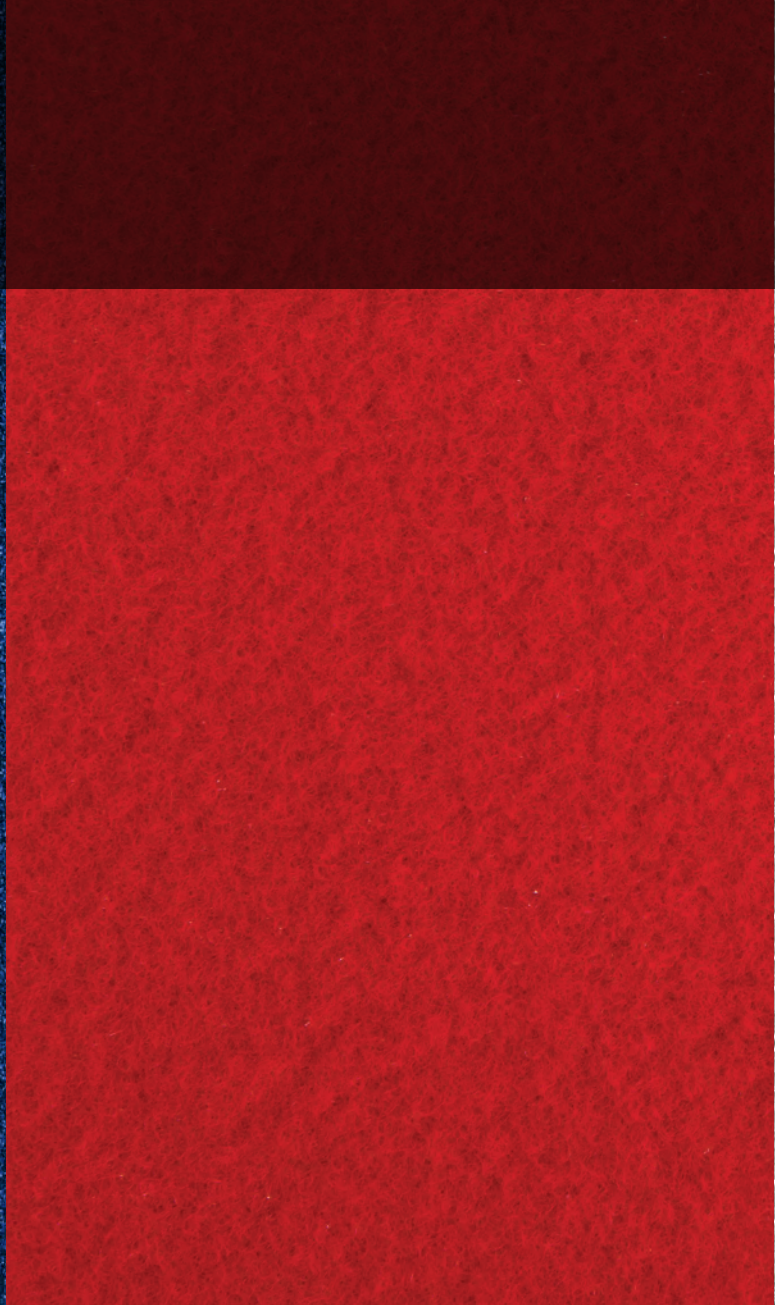
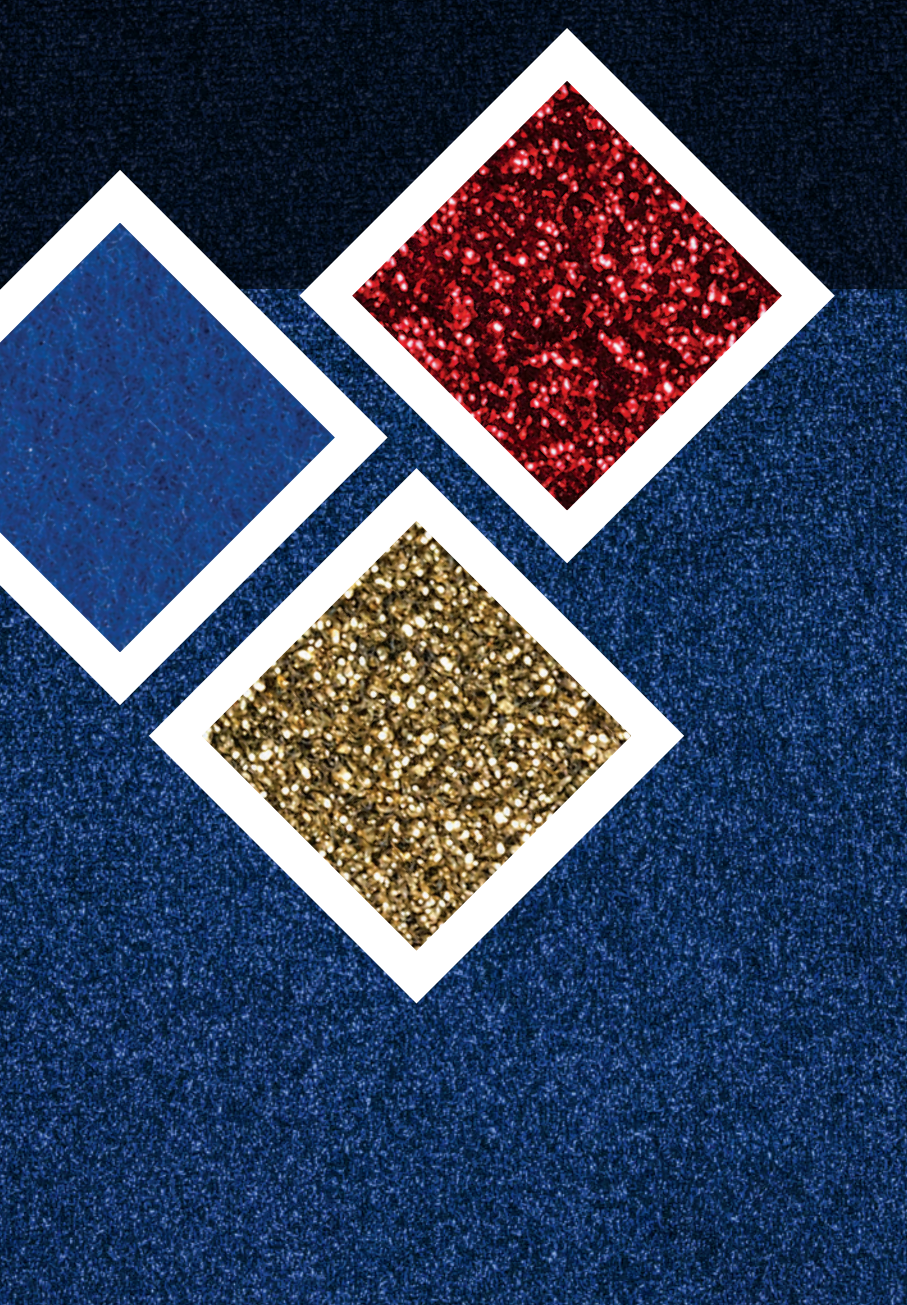

## GALA

**Inherently Flame Retardant.** Gorgeous metallic colors for the most sparkle. Use this synthetic carpet both indoor and outdoor.

- Width: 6'-6"
- Roll length: approx. 45 yards
- Weight: 3.3 lbs/linear yard

Cut Price Per Yard	Full Piece Per Yard
27.00	18.00

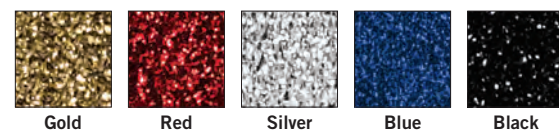

## EVENT CARPET

**Inherently Flame Retardant.** Event Carpet is a thin, durable and economical carpet. Made from 100% Polypropylene Fiber. Great for exhibit hall floors, shows, fairs and meetings, both indoor and outdoor. Event carpet comes rolled with a protective layer of plastic that can be easily removed just moments before your event.

- Width: 10'
- Roll length: approx. 54 yards
- Weight: approx. 1.3 lbs/sq yard (4.3 lbs/linear yard).
- Thickness: approx. .12"

Cut Price Per Yard	Full Piece Per Yard
22.50	15.00

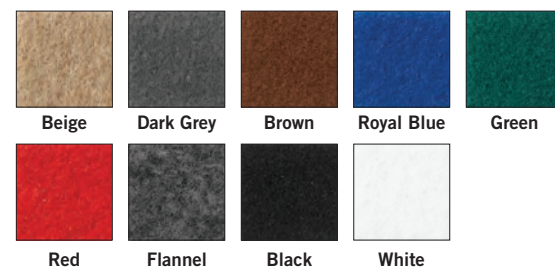

## GLITTER EVENT CARPET

**Inherently Flame Retardant.** Use Glitter Event Carpet for exhibitions, show-windows and anywhere you want sparkle, both indoor and outdoor. Made from 95% Polypropylene Fiber and 5% Polyester.

- Width: 6'-6"
- Roll length: approx. 38 yards
- Weight: approx. 88 lbs per roll.
- Thickness: approx. .12"

Cut Price Per Yard	Full Piece Per Yard
34.50	23.00

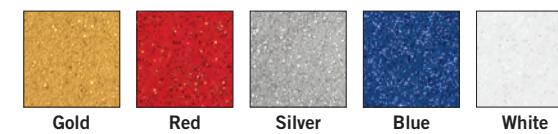

## SHINDIG

**Inherently Flame Retardant.** Shindig catches light from every direction with its glitzy tinsel quality. The shining fibers seem to hover above the carpet base, creating a thin, soft, furry nap.

- Width: 6'-6"
- Roll length: approx. 45 yards
- Weight: 3.3 lbs/linear yard

Cut Price Per Yard	Full Piece Per Yard
30.00	20.00

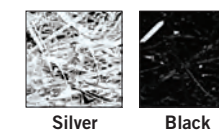

Fabrics
Black Masking
Custom Stage Curtains & Backdrops
Custom Special Event Sewing
Digital Printing
LED Star Drops
Pipe & Base
Rentals
Projection Materials
Flooring
Curtain Track
Stage Equipment, FXs & Mirrors
DMX Winches
Scenery Props
Shop & Production Supplies
Tape
Film & Video Supplies
Index



# LUX Event Carpet



Product: Lux Event Carpet; *The Mountaintop*, Geva Theatre Center, Rochester, NY; Designer: Robert Koharchik; Scene Shop: Geva Theatre Center; Actors: Royce Johnson as Martin Luther King, Jr., and Joniece Abbott-Pratt as Camae; Photo: Ken Huth

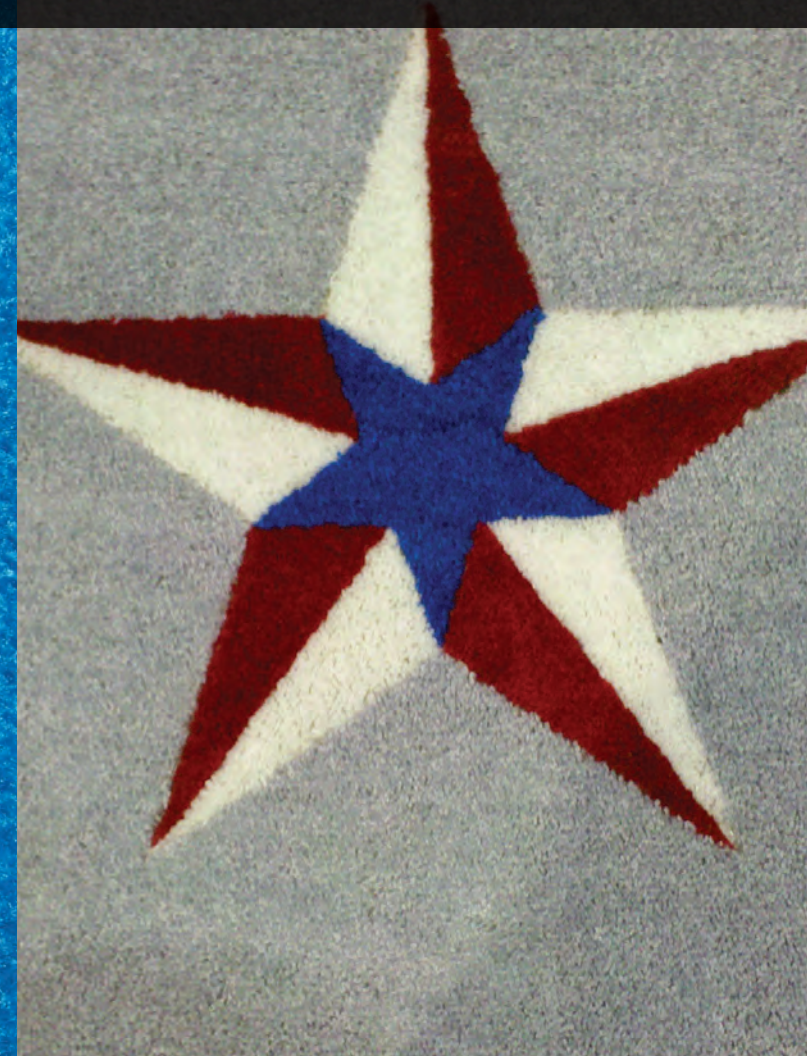

## LUX EVENT CARPET & AREA RUGS

**Inherently Flame Retardant.** Lux Event Carpet & Area Rugs are the premium event carpeting used at high profile gala events at venues throughout the country.

- Price includes cutting & binding
- Custom shapes, colors & sizes available\*
- Latex, no-slip backing available\*
- Virtually any size available  
*(carpet can be bound and seamed on site\*)*
- Low pile Backstage Black available
- Stair treads also available

\*Additional costs and lead times. Call for details.

Width	Price Per Foot of Length
3'	7.65
3'1" - 4'	8.45
4'1" - 5'	9.95
5'1" - 6'	11.50
6'1" - 7'	13.95
7'1" - 8'	15.50
8'1" - 9'	17.30
9'1" - 12'	19.95

## LUX EVENT CARPET CUSTOM INLAY

**Inherently Flame Retardant.** Stock colors can be cut and inlaid into Lux Event Carpet to form your design. Use this for corporate logos, lettering or design patterns. Just send us your layout drawn to scale and colors.

Call to discuss feasibility, timing and cost.

## LUX INDOOR & OUTDOOR RED CARPET RUNNERS

**Inherently Flame Retardant.** Fully bound, red carpet runner is perfect for your next event. Purchase by the foot in widths ranging from 3'-12'. Price includes cutting & binding.

Width	Price Per Foot of Length
3'	6.75
3'1" - 4'	7.50
4'1" - 5'	8.95
5'1" - 6'	10.95
6'1" - 7'	12.95
7'1" - 8'	15.00
8'1" - 9'	17.00
9'1" - 12'	19.95

ROSE BRAND CARPETING MEETS CODE OF FEDERAL REGULATIONS (CFR): COMMERCIAL PRACTICES 1630 & 1631 VIA TESTS FF 1-70 & FF 2-70: SURFACE FLAMMABILITY OF CARPETS.

- Fabrics
- Black Masking
- Custom Stage Curtains & Backdrops
- Custom Special Event Sewing
- Digital Printing
- LED Star Drops
- Pipe & Base
- Rentals
- Projection Materials
- Flooring
- Curtain Track
- Stage Equipment, FXs & Mirrors
- DMX Winches
- Scenery Props
- Shop & Production Supplies
- Tape
- Film & Video Supplies
- Index



# Curtain Track

- Curtain Track .....268
- DMX Track Runner .....269
- Triple E Curtain Track .....270
- Triple E Curtain Track Motors.....278
- Rose Brand Touch Panel Controller.....279
- ADC Curtain Track .....280
- ADC Curtain Track Motors & Controllers.....286
- ADC Curtain Track Wall Brackets.....287
- Kirsch Track .....288
- Rose Brand Custom Bending & Components .....289
- Rose Brand Custom Bending.....289
- Rose Brand Custom Components.....289
- Stage Rigging & Project Management .....290

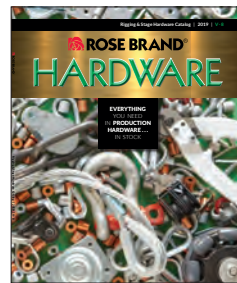

ORDER HARDWARE CATALOG ONLINE



Products: Encore Curtains, Custom Sewing and ADC Track; Impact Hub NYC; Designer/Photo: Sam Utne

- Fabrics
- Black Masking
- Custom Stage Curtains & Backdrops
- Custom Special Event Sewing
- Digital Printing
- LED Star Drops
- Pipe & Base
- Rentals
- Projection Materials
- Flooring
- Curtain Track**
- Stage Equipment, FXs & Mirrors
- DMX Winches
- Scenery Props
- Shop & Production Supplies
- Tape
- Film & Video Supplies
- Index



## Curtain Track

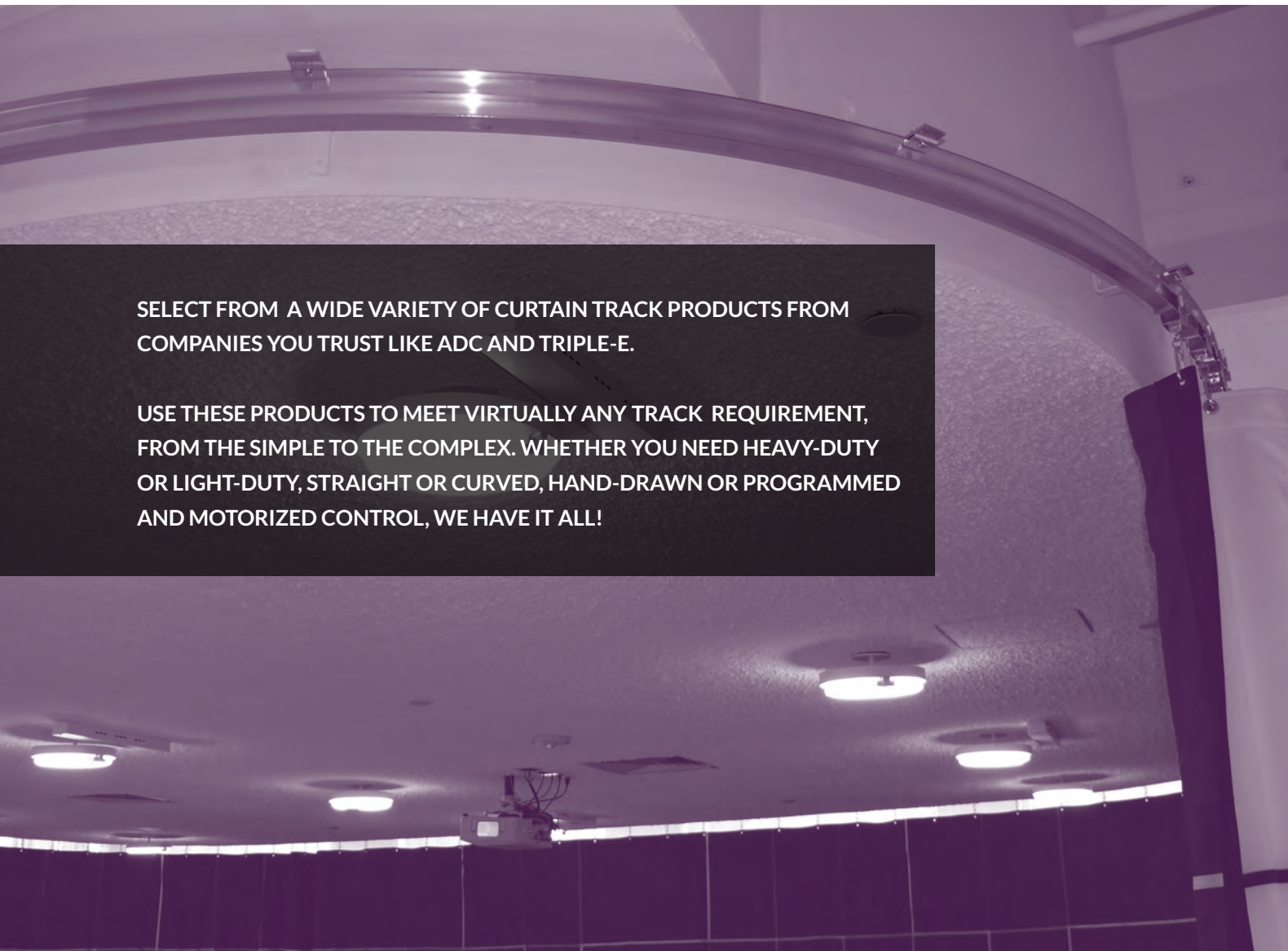

SELECT FROM A WIDE VARIETY OF CURTAIN TRACK PRODUCTS FROM COMPANIES YOU TRUST LIKE ADC AND TRIPLE-E.

USE THESE PRODUCTS TO MEET VIRTUALLY ANY TRACK REQUIREMENT, FROM THE SIMPLE TO THE COMPLEX. WHETHER YOU NEED HEAVY-DUTY OR LIGHT-DUTY, STRAIGHT OR CURVED, HAND-DRAWN OR PROGRAMMED AND MOTORIZED CONTROL, WE HAVE IT ALL!

CURTAIN TRACK QUICK REFERENCE		
USAGE	RECOMMENDED TRACK	PAGE
STAGE TRACK	ADC 280 Series, 170 Series	280-283
	EEE Unitrack, Erail, Chainbeam, Unibeam, Chaintrack	270-277
STUDIO (CYC) TRACK	ADC 140 Series, 132 Series	284-285
	EEE Unitrack, Erail	270-273
INTERIOR/WINDOW CURTAIN TRACK	ADC 220 Series, 113 Series	285
PREMIUM TRACK	EEE Unibeam, Chaintrack, Chainbeam	274-275, 277

## DMX Track Runner

**wahlberg**  
MOTION DESIGN

The Track Runner is a motorized, DMX controlled carrier running along a modified section of Triple E Unibeam track. Attach scenic elements, light fixtures, curtain panels or virtually anything that requires linear movement on stage or at an event or exhibition. Using advanced encoders and 16-bit DMX control, the Track Runner is easily programmed for precise positioning and travel. For greater versatility, use with a wireless DMX transceiver for fully independent, wireless movement.

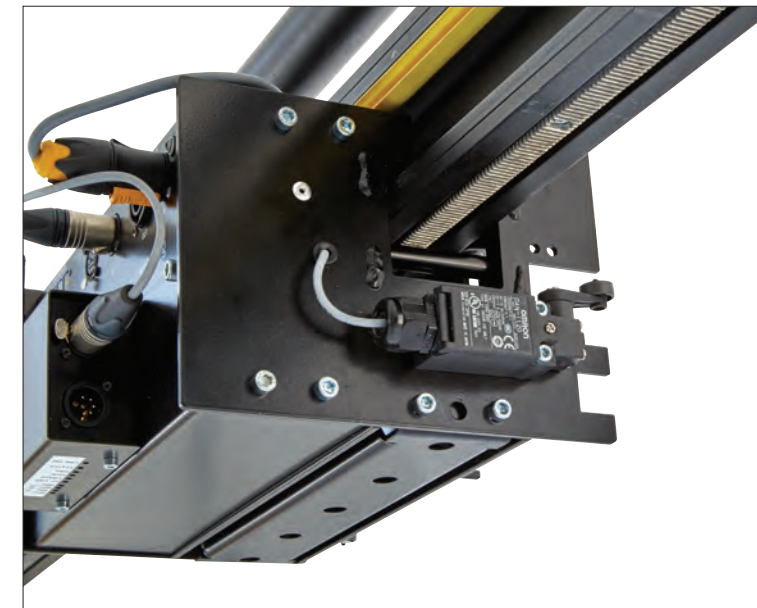

### DMX TRACK RUNNER

Part No. WAHL0009  
**\$2,525.00**

#### Benefits

- Independent drive units allow for complex tracking movements impossible with a leading track rig.
- Allows for motorized control with serpentine curves in track.
- Precise and repeatable positions and limits easily set via 16-bit DMX
- Gear rack drive enables inclined motion up to 30-degrees (reduced load limits)

#### Specifications

- 100 Kg (220lb) load limit on Track Runner  
250 Kg (550 lbs) /meter load limit on Unibeam Track
- Fast Motor Option: appx 3 - 16 inch/sec. speed (dependent on load)  
Slow Motor Option: appx 1.5 - 9 inch / sec. speed (dependent on load) WAHL0019
- Maximum Track length: 165ft
- 5-pin DMX input and pass through Optional Wireless DMX Transmitter
- 6 Channels of DMX control
- 16-bit DMX precision
- 15A max on buss rail
- PowerCon TRUE1™ Input and pass thru
- 120VAC input, 200 watt consumption  
Optional 208/240VAC
- 6.30 x 11.42 x 7.87 in; 23.5lbs

### DMX TRACK RUNNER

ITEM NUMBER	ITEM/DESCRIPTION	PRICE
WAHL0011	Track for Track Runner - 10 ft. Section	1,750.00
WAHL0012	Track Runner Wireless DMX Receiver	375.00





**E RAIL – COMPACT, STRONG AND QUIET.**

E RAIL's small profile and superbly engineered, ball raced, nylon wheels make it practically silent. It's ideal for cruise ships, small stages, conference centers, hotels, schools, and places of worship. E RAIL also embodies Triple E's reputation for reliability, flexibility and high quality on state-of-the-art, large-scale systems.

E RAIL's one piece aluminum extrusion track is available in 10' or 20' lengths. It's joined by a steel plate and set screws in the top slot, and a single roll pin in the base (located within the running surface). E RAIL is mounted by means of suspension fittings, such as a pipe clamp or threaded rod, into a special channel nut in the top slot. E RAIL can be curved to order with a radius of 1'-8" or larger. Curve Cord Guides are necessary when stringing a curved track.

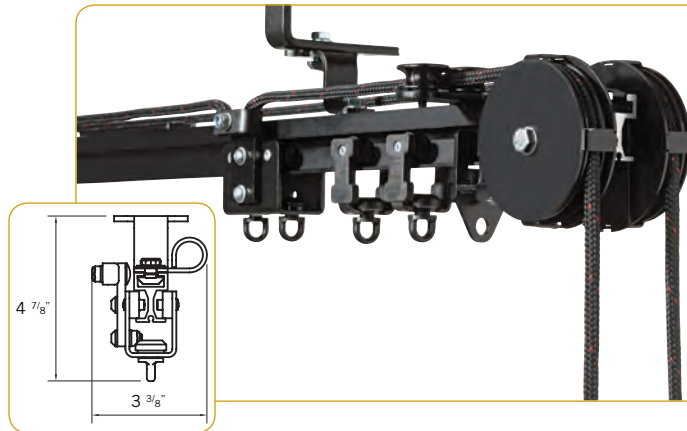

**LOAD RATING**

APPROVED LOADINGS AT 5:1 SAFETY FACTOR				POINT LOAD			UNIFORMLY DISTRIBUTED LOAD		
				SUSPENSION POINT EVERY			SUSPENSION POINT EVERY		
ITEM/DESCRIPTION	ITEM NUMBER	PART NUMBER	SWL	1m	2m	3m	1m	2m	3m
TRACK SECTION	EEEE0001/0002	ERL01	-	77 lbs	26 lbs	-	154 lbs	53 lbs	-
TWO WHEEL RUNNER CARRIER	EEEE0004	ERL06	33 lbs	-	-	-	-	-	-
PIPE CLAMP	EEEE0018	ERL14	88 lbs	-	-	-	-	-	-
MOUNTING BRACKET	EEEE0010	ERL17	163 lbs	-	-	-	-	-	-
CURVE TRACK SUSPENSION BRACKET	EEEE0014	ERL23	187 lbs	-	-	-	-	-	-
12 WHEEL MASTER CARRIER FOR WALKALONG	EEEE0033	ERL0712	66 lbs	-	-	-	-	-	-

**E RAIL COMPONENTS**

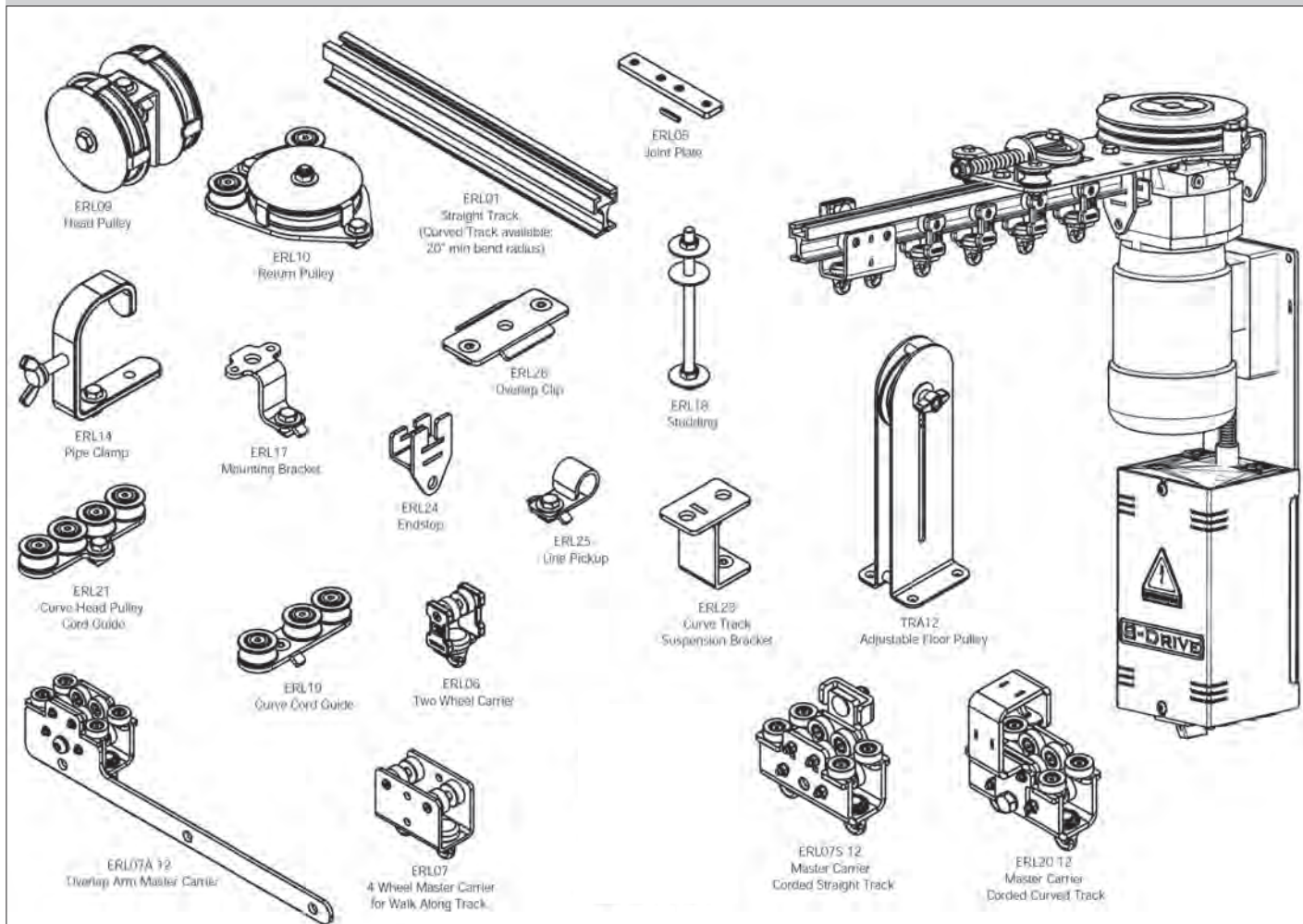

E RAIL COMPONENTS						
GROUP	ITEM/DESCRIPTION	ITEM NUMBER	PART NUMBER	UNIT WT LBS	PRICE EACH	
TRACK	STRAIGHT TRACK 10'-0" length	EEEE0001	ERL01	6.30	162.56	
	STRAIGHT TRACK 20'-0" length	EEEE0002	ERL01	12.60	325.12	
	CURVED TRACK	N.A.	ERL01C	N.A.	Call for price	
	JOINT PLATE	EEEE0003	ERL05	0.64	24.02	
CARRIERS	TWO WHEEL CARRIER	EEEE0004	ERL06	0.11	18.56	
	MASTER CARRIER FOR WALKALONG TRACKS (4 WHEELS)	EEEE0005	ERL07	0.44	123.01	
	MASTER CARRIER FOR WALKALONG TRACK (12 WHEELS)	EEEE0033	ERL0712	0.45	122.94	
	MASTER CARRIER FOR CORDED STRAIGHT TRACK (12 WHEELS)	EEEE0027	ERL07S-12	1.05	177.35	
	MASTER CARRIER FOR CORDED CURVED TRACK (12 WHEELS)	EEEE0012	ERL20-12	1.21	165.82	
	MASTER CARRIER FOR CORDED STRAIGHT TRACK & LIMIT STRIKER (12 WHEELS)	EEEE0028	ERL07SL12	1.32	162.94	
	MASTER CARRIER OVERLAP ARM (12 WHEELS)	EEEE0029	ERL07A12	0.55	31.14	
PULLEYS	HEAD PULLEY	EEEE0008	ERL09	1.98	155.65	
	RETURN PULLEY	EEEE0009	ERL10	1.68	134.54	
	FOOT STIRRUP	EEET0016	TRA11	2.69	97.54	
	ADJUSTABLE FLOOR PULLEY	EEET0017	TRA12	3.13	122.72	
SUSPENSION PARTS	GIRDER CLAMP	EEET0018	TRA13	3.59	69.06	
	PIPE CLAMP FOR O.D. RANGE OF 1½" TO 2"	EEEE0018	ERL14	1.32	21.82	
	WALL BRACKET	EEET0021	TRA16	2.76	47.39	
	WALL BRACKET HEAVY DUTY	EEET0059	TRA16HD	3.30	109.73	
	MOUNTING BRACKET	EEEE0010	ERL17	0.49	23.61	
	M8 UNIRAIL ATTACHMENT NUT	EEEE0019	M8RAILNUT	0.02	2.81	
	STUDDING M8 X 150MM (5-7/8" LONG) COMES WITH NUTS AND WASHERS DIRECT TO TRACK	EEEE0030	ERL18	0.44	10.90	
	STUDDING M8 X 150MM COMES WITH NUTS AND WASHERS DIRECT TO TRACK	EEET0023	TRA18	0.44	10.90	
	CURVE CORD GUIDE	EEEE0011	ERL19	0.40	61.15	
	HEAD PULLEY CORD GUIDE	EEEE0013	ERL21	0.60	82.96	
CURVED TRACK PARTS	CURVE TRACK SUSPENSION BRACKET	EEEE0014	ERL23	0.51	35.69	
	ACCESSORIES	ENDSTOP	EEEE0015	ERL24	0.26	23.54
	LINE PICKUP	EEEE0016	ERL25	0.26	23.54	
	OVERLAP CLIP	EEEE0017	ERL26	0.40	26.00	
CORD	PREASSEMBLED OVERLAP SECTION (COMES WITH OVERLAP CLIPS)	EEEE0031	ERL26C	6.86	280.22	
	½" BLACK POLYESTER CORD PER FOOT	EEET0034	TRA27	0.09	1.86	
DRIVES	S DRIVE. Curtain Track Motor designed to fit Erail straight and curved track layouts. It is intended as a quick plug and play system operating on 110V. 165lb capacity on straight track and 110lb capacity on curved track. Comes with pendant controller.	EEEE0022	SDRV	39.60	4,262.09	
	T-DRIVE. Curtain track motor designed to fit the Unitrack, Unibeam, and E-Rail systems for straight and curved track layouts. It is intended as a quick plug and play system operating on 110v. 660 lbs capacity on a straight track. Comes with pendant controller.	EEEE0002	TDRIVE	55.00	5,941.50	
	REMOTE PENDANT CONTROLLER FOR MOTOR DRIVES	EEEE0021	PENB10	1.10	419.58	

**NEED INSTALLATION SUPPORT?**

Learn about what's possible with a little ingenuity and customized solutions.

► Stage Rigging & Project Management

Go to [RoseBrand.com](http://RoseBrand.com) for information.



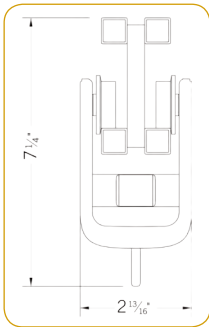
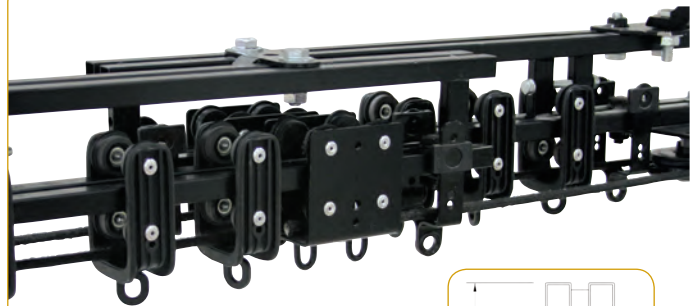

**UNITRACK – IDEAL FOR BOTH TOURING AND PERMANENT INSTALLATIONS.**

For over 20 years, UNITRACK has led the market with robust construction, versatility, and reliability. This reputation, built through countless successful applications in productions and events, has established UNITRACK as a product of choice by professionals worldwide.

With its full range of accessories, UNITRACK is most suitable for heavy-duty applications and will easily meet the demands of all major performance venues and events. All carriers utilize precision-sealed bearings molded into nylon wheels ensuring exceptionally quiet operation. Curve Cord Guides are necessary when stringing a curved track.

UNITRACK is the system for touring:

- Fits into road cases
- Breaks down into easily manageable parts
- The longest piece of straight track is 6'6" long
- High working load capacity
- Two-wheeled carriers can be added or removed anywhere along the track by removing the plastic keeper bar and turning the carrier at right angles to the track

**LOAD RATING**

ITEM/DESCRIPTION	ITEM NUMBER	PART NUMBER	SWL	POINT LOAD			UNIFORMLY DISTRIBUTED LOAD		
				APPROVED LOADINGS AT 5:1 SAFETY FACTOR			SUSPENSION POINT EVERY		
				1m	2m	3m	1m	2m	3m
TRACK SECTION	EEET0001/0004	TRA01/04	-	440 lbs	220 lbs	110 lbs	880 lbs	440 lbs	220 lbs
PIPE CLAMP	EEET0019	TRA14	220 lbs	-	-	-	-	-	-
DEADLINE FIXING	EEET0020	TRA15	330 lbs	-	-	-	-	-	-
WALL BRACKET	EEET0021	TRA16	220 lbs	-	-	-	-	-	-
MASTER CARRIER C/W ADJ. ROPE CLAMP	EEET0011	TRA07	110 lbs	-	-	-	-	-	-
MASTER CARRIER C/W ADJ. ROPE CLAMP & LIMIT STRIKER	EEET0058	TRA07L	110 lbs	-	-	-	-	-	-
2 WHEELED CARRIER	EEET0006	TRA06	55 lbs	-	-	-	-	-	-
4 WHEELED CARRIER	EEET0007	TRA06C	55 lbs	-	-	-	-	-	-
SCENERY CARRIER TOP	EEET0036	TRA28A	110 lbs	-	-	-	-	-	-
SCENERY CARRIER TOP ONLY, HEAVY DUTY	EEET0037	TRA28AHD	275 lbs	-	-	-	-	-	-

**FEATURED UNITRACK COMPONENTS**

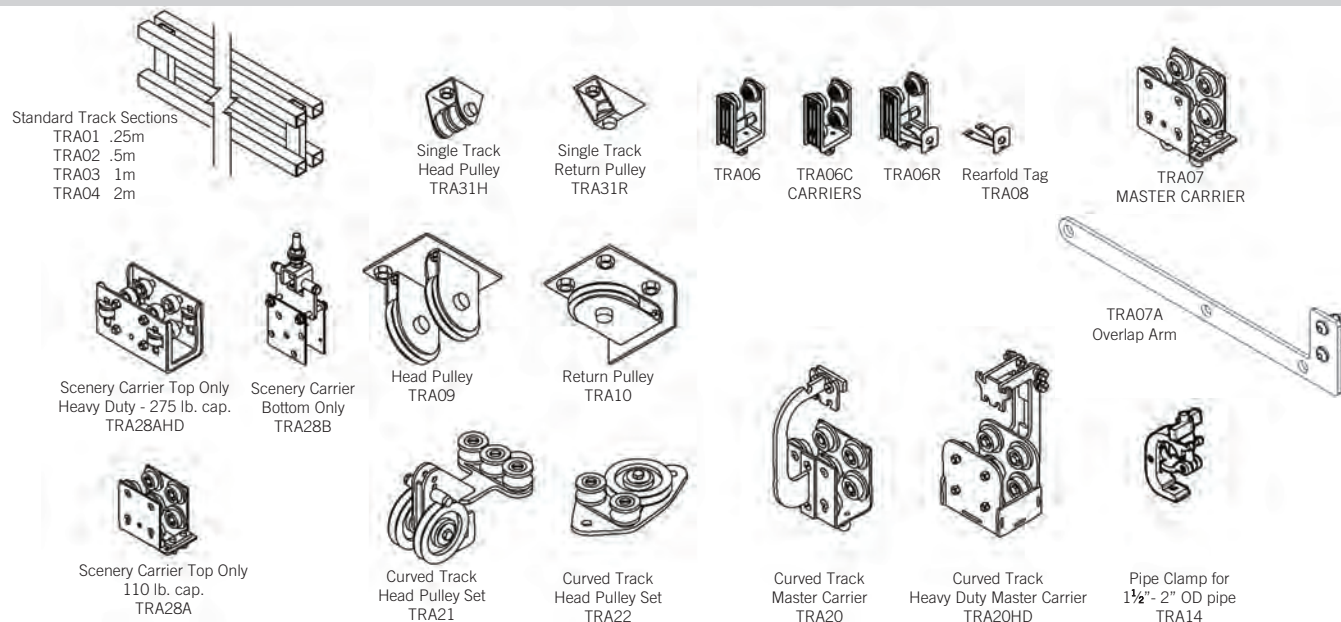

**UNITRACK COMPONENTS**

GROUP	ITEM/DESCRIPTION	ITEM NUMBER	PART NUMBER	UNIT WT LBS	PRICE EACH	
STRAIGHT TRACK	0.25m STANDARD TRACK	EEET0001	TRA01	1.74	50.80	
	0.5m STANDARD TRACK	EEET0002	TRA02	3.22	61.92	
	1m STANDARD TRACK	EEET0003	TRA03	6.11	97.42	
	2m STANDARD TRACK	EEET0004	TRA04	12.17	182.23	
	JOINT SETS	EEET0005	TRA05	0.82	18.36	
CARRIERS	2 WHEELED CARRIER	EEET0006	TRA06	0.55	27.59	
	4 WHEELED CARRIER	EEET0007	TRA06C	0.66	40.89	
	REARFOLD 2 WHEELED CARRIER	EEET0008	TRA06R	0.77	60.09	
	MASTER CARRIER c/w ADJ. ROPE CLAMP	EEET0011	TRA07	1.87	126.32	
	MASTER CARRIER WITH ADJ. ROPE CLAMP & LIMIT STRIKER	EEET0058	TRA07L	2.20	129.83	
	OVERLAP ARM	EEET0010	TRA07A	0.66	35.90	
	REARFOLD TAG	EEET0012	TRA08	0.11	30.41	
	FRONTFOLD BRUSH ASSEMBLY	EEET0061	TRA08F	4.40	173.25	
	SCENERY CARRIER TOP ONLY - 110 LBS CAPACITY	EEET0036	TRA28A	1.96	115.50	
	SCENERY CARRIER BOTTOM ONLY	EEET0039	TRA28B	2.16	90.74	
	SCENERY CARRIER TOP ONLY, HEAVY DUTY - 275 LBS CAPACITY	EEET0037	TRA28AHD	5.11	286.58	
	SCENERY CARRIER ARM, CURVED TRACK	EEET0038	TRA28ARM	0.84	89.57	
	SCENERY CARRIER ARM HEAVY DUTY	EEET0040	TRA28HDARM	1.54	147.49	
	HEAD PULLEY	EEET0014	TRA09	3.77	126.18	
	RETURN PULLEY	EEET0015	TRA10	3.22	100.56	
FOOT STIRRUP FLOOR PULLEY	EEET0016	TRA11	2.69	97.54		
ADJUSTABLE FLOOR PULLEY	EEET0017	TRA12	3.09	122.72		
SINGLE TRACK HEAD PULLEY	EEET0041	TRA31H	1.10	82.50		
SINGLE TRACK RETURN PULLEY	EEET0042	TRA31R	1.10	75.46		
CURVED TRACK	1m RADIUS X 90 DEG. CURVED SECTION	EEET0053	TRC10/90	10.14	441.15	
	1.5m RADIUS X 90 DEG. CURVED SECTION	EEET0054	TRC15/90	15.43	542.56	
	2m RADIUS X 90 DEG. CURVED SECTION	EEET0055	TRC20/90	19.18	624.18	
	3m RADIUS X 90 DEG. CURVED SECTION	EEET0056	TRC30/90	31.97	850.50	
	CURVED TRACK PARTS	CURVE CORD GUIDE SET	EEET0024	TRA19	1.06	93.76
CURVE MASTER CARRIER		EEET0025	TRA20	2.73	218.47	
CURVE MASTER CARRIER (HEAVY DUTY)		EEET0026	TRA20HD	4.52	426.57	
CURVE HEAD PULLEY SET		EEET0027	TRA21	3.81	256.47	
CURVE RETURN PULLEY SET		EEET0028	TRA22	2.69	127.39	
CURVE SUSPENSION BRACKET		EEET0029	TRA23	2.09	55.70	
SIDE CORD PARTS	SIDE CORD GUIDE	EEET0043	TRA32	1.72	123.87	
	SIDE CORD CENTRE OVERLAP DIVERTER	EEET0044	TRA33	4.03	181.44	
	SIDE CORD HEAD & RETURN PULLEY SET (3 PART)	EEET0045	TRA34	5.22	252.84	
	SIDE CORD ROPE CLAMP FOR MASTER CARRIER	EEET0046	TRA35	0.88	65.73	
	SIDE CORD GUIDE HEAVY DUTY	EEET0062	TRA32HD	1.76	107.94	
	SIDE CORD CENTER OVERLAP DIVERTER HEAVY DUTY	EEET0063	TRA33HD	4.18	176.43	
	SIDE CORD HEAD & RETURN PULLEY SET HEAVY DUTY (3 PART)	EEET0064	TRA34HD	5.28	228.33	
	SIDE CORD ROPE CLAMP FOR MASTER CARRIER HEAVY DUTY	EEET0065	TRA35HD	0.88	143.22	
	SUSPENSION PARTS	GIRDER CLAMP	EEET0018	TRA13	3.59	69.06
		PIPE CLAMP FOR O.D. RANGE OF 1 1/2" TO 2"	EEET0019	TRA14	1.32	62.40
DEADLINE FIXING		EEET0020	TRA15	0.64	20.93	
WALL BRACKET SET		EEET0021	TRA16	2.76	47.39	
WALL BRACKET HEAVY DUTY		EEET0059	TRA16HD	3.30	78.88	
OFFSET PLATE		EEET0022	TRA17	0.33	27.60	
STUDDING (5 7/8" LONG INCLUDES NUTS & WASHERS)		EEET0023	TRA18	0.44	10.90	
ACCESSORIES		ENDSTOP	EEET0030	TRA24	0.64	20.93
		FLAT ENDSTOP	EEET0031	TRA24S	0.29	20.93
		LINE PICKUP	EEET0032	TRA25	0.60	20.93
	OVERLAP CLIP	EEET0033	TRA26	1.10	30.41	
	CENTRAL ROPE CROSSOVER FOR REARFOLD TO CENTER BUTT	EEET0066	TRA29	2.60	166.06	
CORD	5/16" BLACK POLYESTER CORD PER FOOT	EEET0034	TRA27	0.09	1.86	
	5/16" WIRE CENTER ROPE PER FOOT	ROPE0084	-	.05	.50	
DRIVES	T-DRIVE. Curtain track motor designed to fit the Unitrack, Unibeam, and E-Rail systems for straight and curved track layouts. It is intended as a quick plug and play system operating on 110v. 660 lbs capacity on a straight track. Comes with pendant controller.	EEEP0002	TDRIVE	55.00	5,941.50	
	T-DRIVE HD. Same as standard T-Drive - 880 lbs capacity on a straight track. Comes with pendant controller.	EEEP0003	TDRIVEHD	60.00	10,094.95	
	REMOTE PENDANT CONTROLLER FOR MOTOR DRIVES With Open, Closed, and Stop Buttons	EEEE0021	PENK10	1.1	419.58	



# Triple E Curtain Track

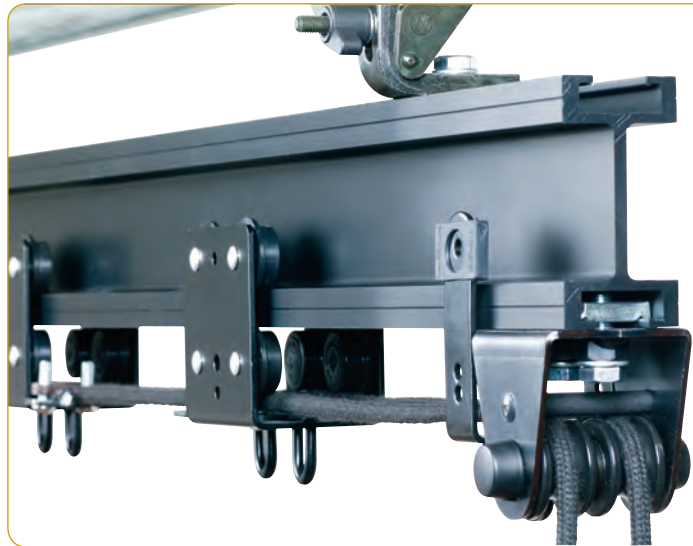

## UNIBEAM – HEAVY-DUTY AND SILENT TRACK FOR PREMIUM INSTALLATIONS.

UNIBEAM combines the versatility of the UNITRACK with the load carrying ability of an "I" beam to double as both a track and a batten.

UNIBEAM allows large spans between pickups. Standard size tee slot accepts universally available channel nuts making for a fast and efficient installation.

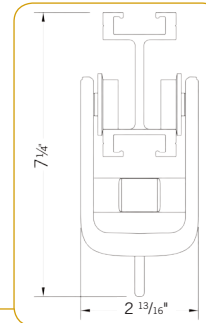

All standard strut bracketry can be used with UNIBEAM.

UNIBEAM has identical dimensions to UNITRACK and shares carriers, but is stocked in 20' lengths. Additionally, UNIBEAM offers a scenery carrier with a safe working load (SWL) of 848 lbs for heavy-duty applications.

UNIBEAM is available as a stock item and can be manually corded or driven by a TracDrive motor or other curtain track machines.

### LOAD RATING

APPROVED LOADINGS AT 5:1 SAFETY FACTOR				POINT LOAD			UNIFORMLY DISTRIBUTED LOAD		
				SUSPENSION POINT EVERY			SUSPENSION POINT EVERY		
ITEM/DESCRIPTION	ITEM NUMBER	PART NUMBER	SWL	1m	2m	3m	1m	2m	3m
TRACK SECTION	EEEEU0001	UBM01/20	-	1,177 lbs	583 lbs	374 lbs	2,354 lbs	1,166 lbs	784 lbs
UNIBEAM SCENERY CARRIER	EEEEU0011	UBM28A	848 lbs	-	-	-	-	-	-

### UNIBEAM COMPONENTS

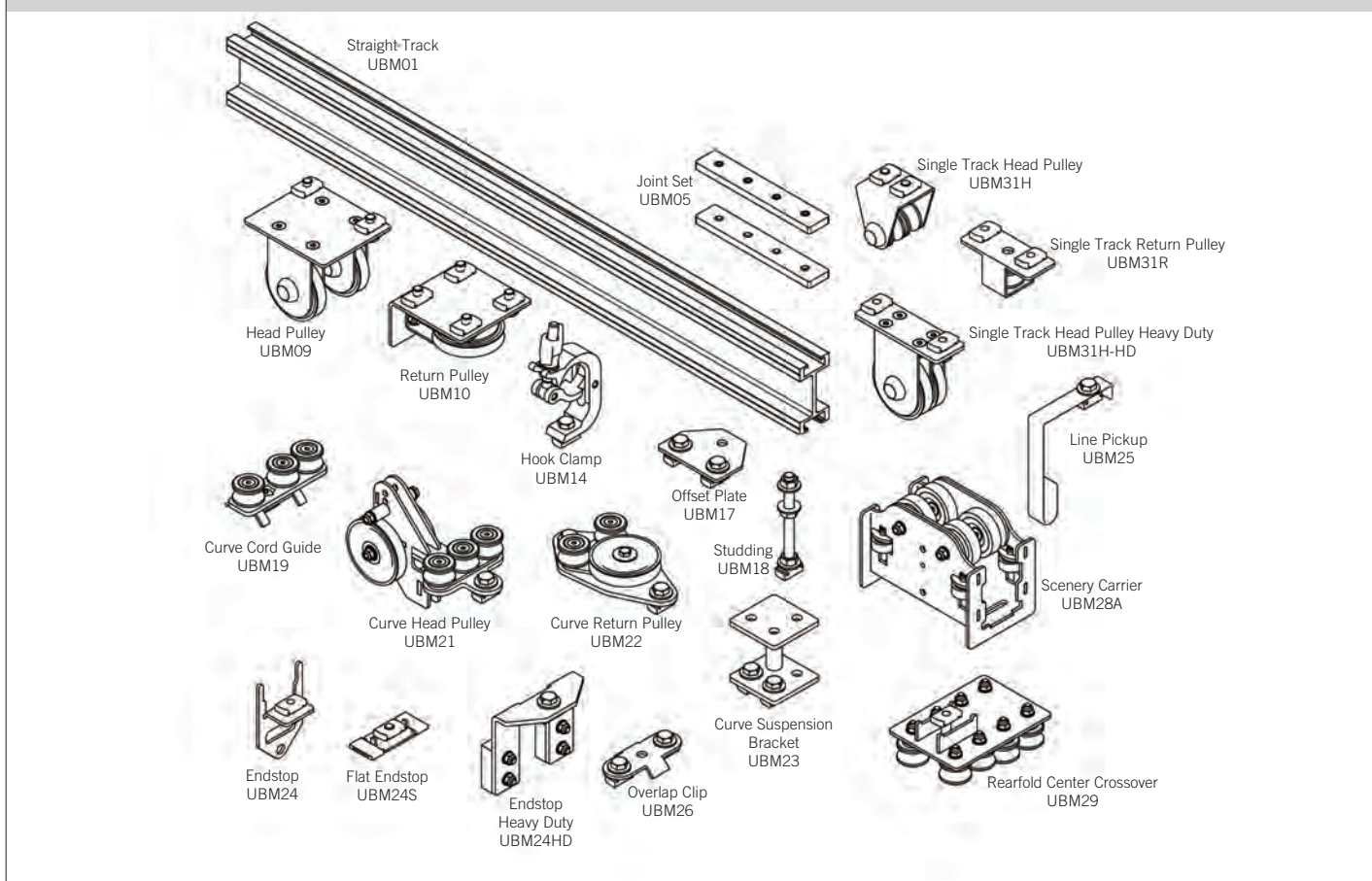

### UNIBEAM COMPONENTS

GROUP	ITEM/DESCRIPTION	ITEM NUMBER	PART NUMBER	UNIT WT LBS	PRICE EACH	
STRAIGHT TRACK	20' LENGTH OF STRAIGHT TRACK	EEEEU0001	UBM01	47.09	581.53	
	JOINT SETS	EEEEU0002	UBM05	0.82	79.38	
CARRIERS	2-WHEELED CARRIER	EEET0006	TRA06	0.55	27.59	
	4-WHEELED CARRIER	EEET0007	TRA06C	0.66	40.89	
	REARFOLD 2 WHEELED CARRIER	EEET0008	TRA06R	0.77	66.09	
	MASTER CARRIER c/w ADJ. ROPE CLAMP	EEET0011	TRA07	1.87	126.32	
	MASTER CARRIER c/w ADJ. ROPE CLAMP AND LIMIT STRIKER (MOTORIZED TRACKS)	EEET0058	TRA07L	2.2	129.83	
	OVERLAP ARM	EEET0010	TRA07A	0.66	35.90	
	REARFOLD TAG - BOLT ON ACCESSORY	EEET0012	TRA08	0.11	30.41	
	FRONTFOLD BRUSH ASSEMBLY	EEEEU0033	UBM08F	4.40	124.54	
	SCENERY CARRIER TOP ONLY - 110 LBS CAPACITY	EEET0036	TRA28A	1.96	115.50	
	SCENERY CARRIER BOTTOM ONLY	EEET0039	TRA28B	2.16	90.74	
	SCENERY CARRIER TOP ONLY, HEAVY DUTY - 275 LBS CAPACITY	EEET0037	TRA28AHD	5.11	267.83	
	SCENERY CARRIER ARM HEAVY DUTY	EEET0040	TRA28HDARM	1.54	147.49	
	UNIBEAM SCENERY CARRIER - 848 LB CAPACITY	EEEEU0011	UBM28A	8.14	484.42	
	OVERLAP ARM FOR UBM28A	EEEEU0027	UBM07A	2.65	98.66	
	HEAD PULLEY	EEEEU0003	UBM09	3.77	131.18	
	RETURN PULLEY	EEEEU0004	UBM10	3.22	100.51	
	SINGLE TRACK HEAD PULLEY	EEEEU0012	UBM31H	1.1	82.50	
	SINGLE TRACK RETURN PULLEY	EEEEU0013	UBM31R	1.1	75.46	
	SINGLE TRACK HEAD PULLEY HEAVY DUTY	EEEEU0034	UBM31HHD	1.98	176.43	
	FOOT STIRRUP	EEET0016	TRA11	2.69	97.54	
ADJUSTABLE FLOOR PULLEY	EEET0017	TRA12	3.09	122.72		
UNIRING	EEEEU0032	UNIRING	0.04	5.19		
CURVED TRACK PARTS	CURVED TRACK PER FOOT (MIN. RAD. 3 FT)	N.A.	UBM01C	N.A.	Call for price	
	CURVE CORD GUIDE SET	EEEEU0014	UBM19	1.06	93.76	
	CURVE MASTER CARRIER	EEET0025	TRA20	2.73	218.47	
	CURVE MASTER CARRIER (HEAVY DUTY)	EEET0026	TRA20HD	4.52	426.57	
	SCENERY CARRIER ARM, CURVED TRACK	EEET0038	TRA28ARM	0.84	89.57	
	CURVE HEAD PULLEY SET	EEEEU0016	UBM21	3.81	263.09	
	CURVE RETURN PULLEY SET	EEEEU0017	UBM22	2.69	127.39	
	CURVE SUSPENSION BRACKET	EEEEU0015	UBM23	2.09	55.70	
	SIDE CORD GUIDE	EEEEU0018	UBM32	1.72	123.87	
	SIDE CORD CENTRE OVERLAP DIVERTER	EEEEU0019	UBM33	4.03	166.70	
SIDE CORD PARTS	SIDE CORD HEAD & RETURN PULLEY SET (3 PART)	EEEEU0020	UBM34	5.22	252.84	
	SIDE CORD GUIDE HEAVY DUTY	EEEEU0028	UBM32HD	1.76	127.38	
	SIDE CORD CENTRE OVERLAP DIVERTER HEAVY DUTY	EEEEU0029	UBM33HD	4.08	290.30	
	SIDE CORD HEAD & RETURN PULLEY SET (3 PART) HEAVY DUTY	EEEEU0030	UBM34HD	5.29	356.08	
	SIDE CORD ROPE CLAMP FOR UBM 28A SCENERY CARRIER	EEEEU0031	UBM35HD	3.31	156.49	
	PIPE CLAMP FOR O.D. RANGE OF 1 1/2" TO 2"	EEEEU0005	UBM14	1.32	62.40	
	GIRDER CLAMP	EEET0018	TRA13	3.59	69.06	
	DEADLINE FIXING	EEEEU0026	UBM15	0.64	62.30	
	WALL BRACKET	EEET0021	TRA16	2.76	47.39	
	WALL BRACKET HEAVY DUTY	EEET0059	TRA16HD	3.30	109.73	
SUSPENSION PARTS	OFFSET PLATE	EEEEU0006	UBM17	0.33	27.60	
	STUDDING (5 7/8" LONG INCLUDES NUTS, CHANNEL NUT & WASHERS)	EEEEU0021	UBM18	0.44	21.98	
	ENDSTOP	EEEEU0007	UBM24	0.64	20.93	
	FLAT ENDSTOP	EEEEU0008	UBM24S	0.29	20.93	
	LINE PICKUP	EEEEU0009	UBM25	0.6	20.93	
	OVERLAP CLIP	EEEEU0010	UBM26	1.1	32.32	
	5/16" BLACK POLYESTER CORD PER FOOT	EEET0034	TRA27	0.09	1.86	
	5/16" BLACK WIRE CENTER ROPE PER FOOT	ROPE0084		0.09	0.50	
	DRIVES	T-DRIVE. Curtain track motor designed to fit the Unitrack, Unibeam, and E-Rail systems for straight and curved track layouts. It is intended as a quick plug and play system operating on 110 v. 660 lb. capacity on a straight track, 440 lb. capacity on a curved track. Comes with a pendant controller.	EEEP0002	TDRIVE	55.12	5,941.50
		T-DRIVE FLOOR MOUNT PEDESTAL. Adapts T-Drive to floor mount position.				190.00
T-DRIVE HD. Same as standard T-Drive, but with greater weight capacity. 880 lb capacity on straight track. 660 lb. capacity on a curved track. Comes with a pendant controller.		EEEP0003	TDRIVEHD	70.55	10,094.95	
REMOTE PENDANT CONTROLLER FOR MOTOR DRIVES With Open, Closed, and Stop Buttons		EEEE0021	PENK10	1.1	419.58	



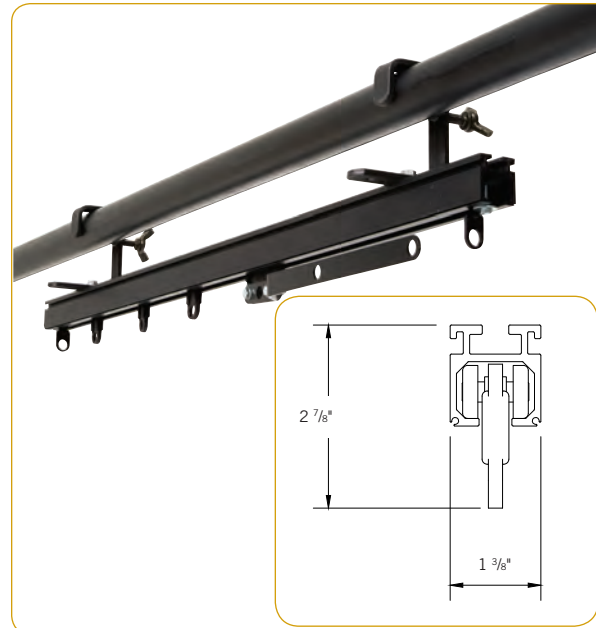

**2-WAY TRACK**

2-Way Track is a medium duty system designed for walk along use such as side masking curtains, perimeter tracks in studios, acoustic curtains or any other application where walk along operation is required. The aluminum construction of this track makes it light and easy to handle. The dimensions of 2-Way track are 1 3/8" wide x 1 3/8" high, making this a compact profile for tight places.

The lower part of the track contains a channel that accepts wheeled carriers that have either plain or ball raced bearings. Both types of carrier are 7/8" wide for calculating stacking distances. The leading carrier is 2 5/8" wide and this can be fitted with an overlap arm if required.

The upper channel accepts an 8mm threaded tee nut which is used to suspend the track using one of the standard or strut type brackets or studding. There are 2 'L' shaped slots in the side of the track for attaching the track flush to a soffit or ceiling with ceiling clips.

At the bottom corners of the extrusion are 2 keyhole slots that accept roll pins to align the running surfaces when the track sections are joined. Each joint set is comprised of a flat plate with four set screws that fit into the top slot with 2 roll pins.

2-Way can be rolled to any radius, the minimum being 2' 5", Rose Brand stocks lengths of 20' with a black anodized finish.

**2-WAY PRODUCTS**

GROUP	ITEM	ITEM NUMBER	PART NUMBER	UNIT WT LBS	PRICE
TRACK	20' LENGTH OF STRAIGHT TRACK	EEE20002	2W01B	2.64	266.33
	JOINT PLATE	EEE30002	2W05	0.66	37.95
CARRIERS	PLAIN WHEEL CARRIER	EEE30004	2W06P	0.02	8.51
	BALL RACED WHEEL CARRIER	EEE30003	2W06C	0.02	15.31
	MASTER CARRIER	EEE30007	2W07W	0.11	60.10
SUSPENSION PARTS	CHANNEL NUT M8	EEEE0019	ERCN8	0.02	2.81
	HOOK CLAMP BLACK	EEEE0018	ERL14	1.32	21.82
	CEILING MOUNT CLIPS (5 PAIRS)	EEE30016	2W30	0.22	19.88
	WALL BRACKET	EEET0021	TRA16	2.76	47.39
	STUDDING M8 X 150MM.(5-7/8" LONG). Comes with nuts and washers direct to track	EEET0023	TRA18	0.44	21.98
ACCESSORIES	ENDSTOP	EEE30014	2W24	0.07	16.44
	DEADLINE FIXING (USE WITH ERL17 OR ERL23)	EEE20003	2W15	0.64	10.38
	CEILING MOUNT CLIPS (5 SETS)	EEE20004	2W30	0.22	19.93
	OVERLAP CLIP	EEE20005	2W26	0.44	21.17

**2-WAY COMPONENTS**

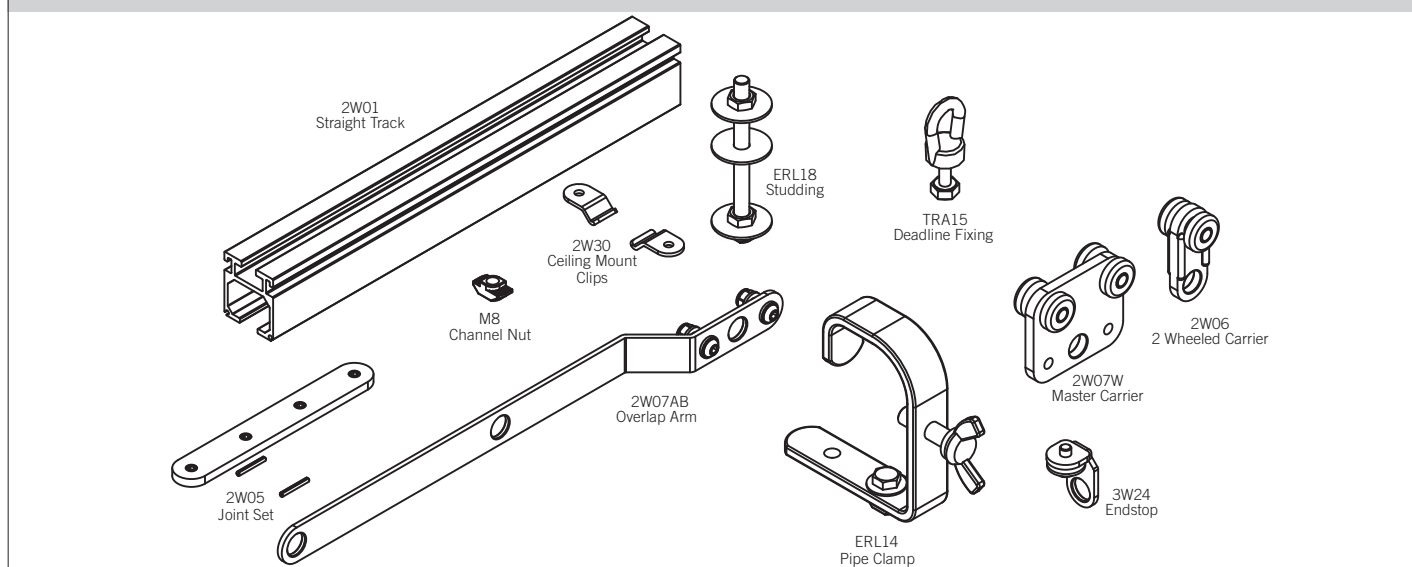

**CHAINBEAM – PRECISE MOTORIZED CONTROL WITH DUPLEX CHAIN INSTEAD OF ROPE FOR HEAVY WEIGHT CURTAINS AND SCENERY.**

CHAINBEAM is an aluminum extruded black anodized track, with external dimensions identical to Triple E systems UNITRACK and Unibeam. CHAINBEAM is for permanent or semi-permanent installations and can carry heavier loads than a system such as UNITRACK. In fact, CHAINBEAM has all of the advantages of another Triple E system, Unibeam, except that CHAINBEAM uses a motor and duplex chain that's integrated into a guide channel in the bottom of the track, instead of rope. This provides precise control for curtains or heavy scenic elements.

Custom track available. Call for Pricing.

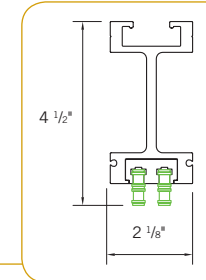

**CHAINBEAM COMPONENTS**

USE SAME COMPONENTS AS UNIBEAM (SEE PAGE 275)



**CHAINTRACK – PERFECT FOR LIMITED WING AND STACKING SPACE**

Great for turning non-traditional venues into working theatre spaces. Ideal for:

- Cruise Ships
- Restaurants & Clubs
- Theatres
- Exhibit Booths

Using a standard duplex roller chain, CHAINTRACK opens up enormous possibilities for designers, among them:

- Show both sides of a curtain
- Continuously moving flat background
- Round curves and tight corners

CHAINTRACK can turn up to 180° in as little as 2" radius, allowing the curtains to be tracked in a storage area just a fraction of the curtain's actual length. A curtain on CHAINTRACK can double back on itself giving it the ability to store flat, rather than bunched, while still suspended.

Custom track available. Call for Pricing.

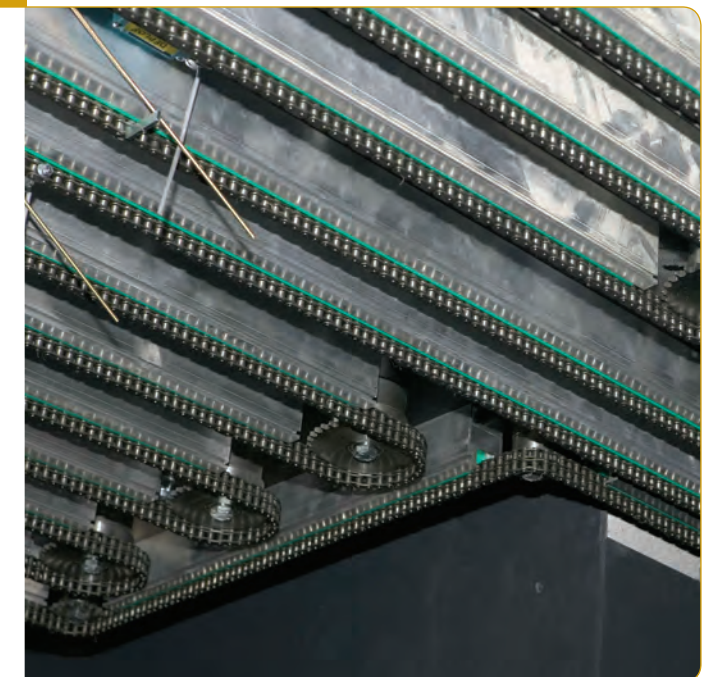
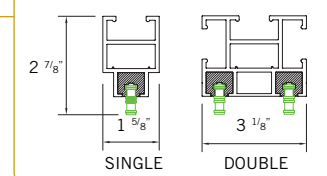



## Triple E Curtain Track Motors

### CHAINRAIL

CHAINRAIL combines the versatile E Rail track system with the precision of a chain driven system. The aluminum construction makes this track easy to handle. The E Rail carriers provide almost silent operation, making this an ideal choice for stage, conference hall, and architectural installations. The dimensions of CHAINRAIL track are 3 1/8" wide x 3 7/8" high. The chain is neatly guided in UHMW to allow this track to go places many other tracks can't.

The top and sides of the CHAINRAIL are identical to Chaintrack and are designed to accept standard channel nuts for attaching suspension fittings, drive components and joint bars. Motors can be mounted either above or below the track. The opposite end has a chain tensioning device that consists of a large diameter Duplex chain sprocket and a pair of idler guides. The chain tension can be adjusted by rotating a central bolt.

The CHAINRAIL master carrier is fitted with a drive comb that is mounted on the side of the carrier and engages the chain. It is retained by bolts that allow the drive to be easily disengaged during commissioning. The chain can be bedded in and tensioned prior to the load being applied. With this drive arrangement, the chain is only being used to pull the load; the weight is carried by the track extrusion. CHAINRAIL can be curved to a minimum radius of 24". Depending on overall track length and the load being carried, S-Curves are also possible.

CHAINRAIL is a custom configured system. Call a Rose Brand representative to learn more.

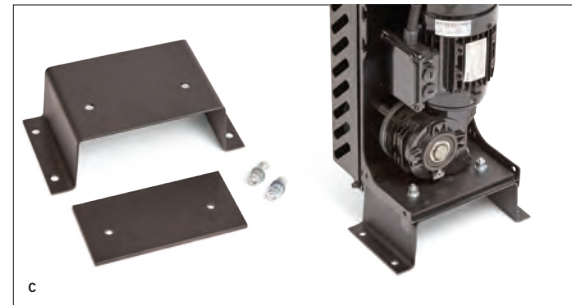
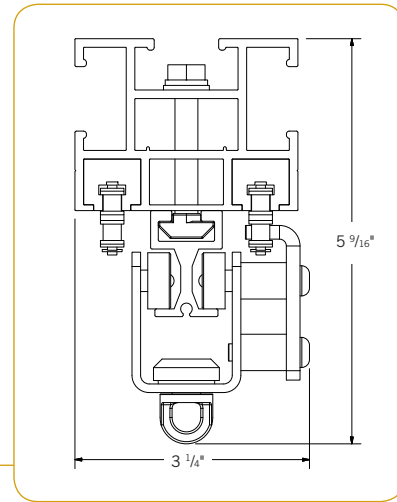

### DRAW CURTAIN MOTOR SELECTOR GUIDE

	ITEM	BRAND	MODEL NO.	HP	POWER REQUIRED	ROPE SPEED	TYPE	MAX ROPE TRAVEL (IN FEET- ONE WAY)	MAX CURTAIN WEIGHT FOR STRAIGHT TRACK	MOUNT	TRACK TYPE	PRICE
A	S-DRIVE	TRIPLE E	S DRIVE	1/4	120/220V - 1 Phase	0 to 135 ft/min	Friction Drive	Unlimited	165 lbs	Track	E Rail	4,262.09
B	T- DRIVE	TRIPLE E	T-DRIVE	1/2	120V - 1 Phase - 15 Amp	Variable speed Max. 137.4 ft/min	Friction Drive	Unlimited	660 lbs	Track/ Ceiling/ Wall	E Rail, Unitrack, Unibeam	5,941.50
B	T-DRIVE HD	TRIPLE E	T-DRIVE HD	1	120V - 1 phase - 15 Amp	Variable speed Max. 137.4 ft/min	Friction Drive	Unlimited	880 lbs	Track/ Ceiling/ Wall	E Rail, Unitrack, Unibeam	10,094..95
C	FLOOR MOUNT FOR T-DRIVE											190.00

### S-DRIVE AND T-DRIVE

Developed specifically for Triple E track, these motors are simple and reliable, and installation is easy. Mounting directly to the end of the track, the drives are plug-and-play. Just connect a power cord and control line (a pendant controller, for example) and they are ready for use. No hardwiring; no cable or cord runs to a floor mounted drive system.

The S-Drive is intended for use with E-Rail and the T-Drive is intended for use with E-Rail UniTrack and UniBeam. With appropriate adapter plates however each motor can be fit to any track.

## Rose Brand Touch Panel Controller



### ROSE BRAND TOUCH PANEL CONTROLLER

The Rose Brand Touch Panel Controller for track motors simplifies the complex task of setting up, programming and operating your motorized curtain track. Easily customized to the unique requirements of your installation, the TPC System allows for multi-position and multiple-axis control, and can accommodate multiple control stations. The system uses connectorized cable assemblies for plug-and-play set-up eliminating the need to field wire terminal blocks. The Touch Panel Controller is a fully independent control system but can also be configured to be triggered by show control or other building automation solutions. Rose Brand Engineers will help to customize the system as needed.

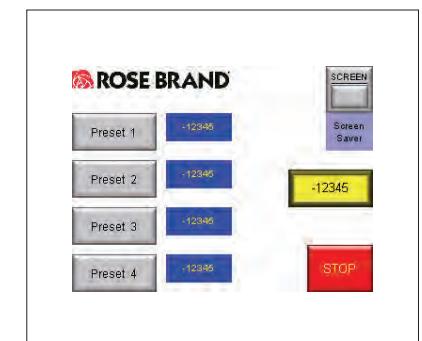

Touch panel controller for track motors



**ROSE BRAND  
NOW STOCKS  
140, 280, 170  
TRACK SERIES IN  
BLACK IN CA  
AND NJ.**

**ADC 280 TRACK SELECTOR CHART**

TRADE NAMES METAL CONSTRUCTION AND SERIES	APPROX. MAX. CURTAIN WT. PER FOOT OF TRACK (LBS.)	MAX. TRACK LENGTH BI-PARTING	APPROX. CURTAIN STACKING SPACE PER LINEAR FT. TRACK	MODEL NO.	DIFFERENCES: TIRE/AXLE (SINGLE CARRIER PART NUMBER)	CWANA** PRICE PER FOOT
<b>280 SERIES SILENT STEEL®</b>	20	60'	2.4"	280	Polyethylene/Ball-Bearing (2801, Nylon Block)	49.04
	25	60'	2.4"	280-A	Polyethylene/Ball-Bearing (2801-B, Steel Block)	52.37
	30	80'	2.4"	281	Neoprene Ball-Bearing (2849, Steel Block)	98.78
	50	80'	2.4"	282	Nylon/Ball-Bearing (2851, Steel Block)	87.35
	50	Any	2.4"	283-N	Nylon/Ball-Bearing (2851, 8" pulleys, 1/2" rope)	97.35
	30	Any	2.4"	283-R	Neoprene/Ball-Bearing (2849, 8" pulleys, 1/2" rope)	118.70

**\*\*CWANA: Complete With All Necessary Accessories.**  
 CWANA price includes carriers, pulleys, endstops, hanging clamps, splice clamps and rope if necessary.  
 • Track will be sold in stock lengths only. If precise cutting is required, add 9.00 per cut.  
 • In most situations, extra track is needed to allow curtains to overlap in the middle.  
 • Track lengths greater than 8' must ship via common carrier.

**280 SERIES SILENT STEEL®**

SILENT STEEL is the most famous name in heavy duty stage tracks. The Model 280 steel series is used in the majority of stage installations with heavy weight curtains of any length, and is particularly quiet in operation. Models 281 and 282 are for use with especially heavy curtains. They are essentially identical to Model 280 except neoprene-tire ball-bearing carriers are supplied with Model 281, while larger diameter floor and end pulleys and heavy duty nylon-tire ball-bearing carriers are furnished with Model 282 and Model 283. 280 Series tracks cannot be curved. 1 carrier per foot included in CWANA price.

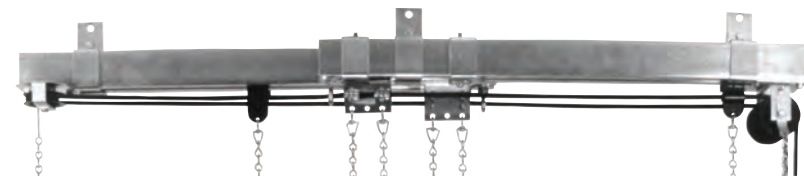

Rose Brand stocks ADC 280 Series Track in Black!

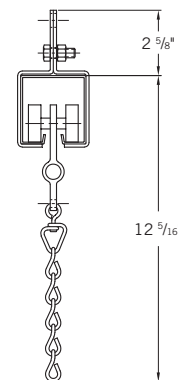

**280 SERIES COMPONENTS**

- 2800 Channel
- 2824 Suspended Splicing Clamp
- 2824-A Ceiling Splicing Clamp
- Pipe Clamp
- 2808 Hanging Clamp
- CPS-1 Center Pipe Support
- Threader
- 2807 Lap Clamp
- 2809 End Stop
- 2803 Live End Pulley
- 2804 Dead End Pulley
- 2805 Adjustable Floor Pulley
- 2865 Tension Floor Pulley
- Single Carrier
- Master Carrier
- 2839 Overlapping Master Carrier
- Back Pack Guide
- 2840 Masking/Panel Master Carrier
- Multi-Purpose Carrier

Fabrics  
 Black Masking  
 Custom Stage Curtains & Backdrops  
 Custom Special Event Sewing  
 Digital Printing  
 LED Star Drops  
 Pipe & Base  
 Rentals  
 Projection Materials  
 Flooring  
 Curtain Track  
 Stage Equipment, FXs & Mirrors  
 DMX Winches  
 Scenery Props  
 Shop & Production Supplies  
 Tape  
 Film & Video Supplies  
 Index



**ROSE BRAND  
NOW STOCKS**  
140, 280, 170  
TRACK SERIES IN  
**BLACK IN CA  
AND NJ.**

**ADC 170/260 TRACK SELECTOR CHART**

TRADE NAMES METAL CONSTRUCTION AND SERIES	APPROX. MAX. CURTAIN WT. PER FOOT OF TRACK (LBS.)	MAX. TRACK LENGTH BI-PARTING	APPROX. CURTAIN STACKING SPACE PER LINEAR FT. TRACK	MODEL NO.	DIFFERENCES: TIRE/AXLE (SINGLE CARRIER PART NUMBER)	CWANA** PRICE PER FOOT
<b>170 SERIES BESTEEL® 260 FENESTEEL®</b>	10	40'	1.5"	170, 260	Polyethylene (1701) (260 uses 2602 masters)	47.48
	15	48'	1.5"	171-N	Nylon Ball-Bearing (1737)	47.48
	13	48'	2"	171-R	Neoprene/Ball-Bearing (1749)	53.27
	10	40'	1.5"	172	Polyethylene (1701, 4" pulleys, 5/16" rope)	40.67
	10	Any	1.5"	173	Polyethylene (1701 Walk-Along)	24.03
	13	Any	1.5"	173-N	Nylon/Ball-Bearing (1737 Walk-Along)	37.32
	15	Any	2"	173-R	Neoprene/Ball-Bearing (1749 Walk-Along)	53.27

\*\*CWANA: Complete With All Necessary Accessories.  
CWANA price includes carriers, pulleys, endstops, hanging clamps, splice clamps and rope if necessary.

- Track will be sold in stock lengths only. If precise cutting is required, add 9.00 per cut.
- In most situations, extra track is needed to allow curtains to overlap in the middle.
- Track lengths greater than 8' must ship via common carrier.

**170 SERIES BESTEEL®**

BESTEEL is the most popular medium-duty stage track. The Model 170 steel series is used on the majority of stage installations with medium or light weight curtains with lengths up to about 36'. On slightly heavier installations, Models 171-N or 171-R can be used. The cord operated 170 and 260 series tracks cannot be curved. Model 173, which is for "walk-along" cyclorama and gym divider curtains can be outfitted with pre-manufactured curved sections. 1 carrier per foot is included in CWANA price.

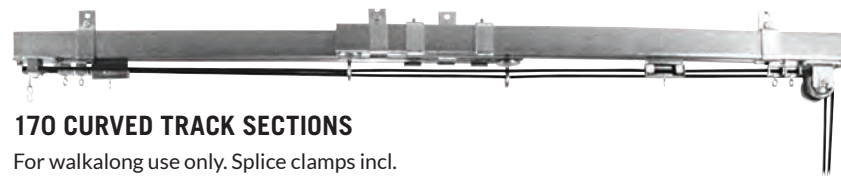
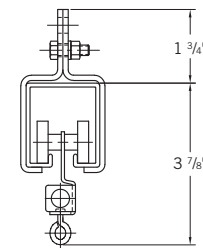

**170 CURVED TRACK SECTIONS**

For walkalong use only. Splice clamps incl.

	Price
1755 Approx. 2' x 2' 45°	344.63
1752 Approx. 3' x 3' 90°	352.95

Rose Brand stocks ADC 170 Series Track in Black!

**170 SERIES COMPONENTS**

**EVERYTHING  
YOU NEED  
IN PRODUCTION HARDWARE...  
IN STOCK**



**ROSE BRAND  
NOW STOCKS  
140, 280, 170  
TRACK SERIES IN  
BLACK IN CA  
AND NJ.**

ADC 140 TRACK SELECTOR CHART						
TRADE NAMES METAL CONSTRUCTION AND SERIES	APPROX. MAX. CURTAIN WT. PER FOOT OF TRACK (LBS.)	MAX. TRACK LENGTH BI-PARTING	APPROX. CURTAIN STACKING SPACE PER LINEAR FT. TRACK	MODEL NO.	DIFFERENCES: TIRE/AXLE (SINGLE CARRIER PART NUMBER)	CWANA** PRICE PER FOOT
<b>140 SERIES RIG-I-FLEX®</b> Aluminum Track (Can be curved - Call for Pricing)  *Spindles and Idler Brackets sold separately.	7	60'	1.8"	140	Nylon/Ball-Bearing (4201)	37.94
	7	60'	1.8"	140-R	Nylon (4237)	37.93*
	15	60'	1.8"	141	Nylon/Ball-Bearing (4201 Straight Only)	40.53*
	15	60'	1.8"	141-R	Nylon/Ball-Bearing (4237)	37.93*
	15	Any	1.8"	142	Nylon/Ball-Bearing (4201 Walk-Along)	31.83
	15	Any	1.8"	142-R	Nylon (4237 Walk-Along)	30.47

**\*\*CWANA: Complete With All Necessary Accessories.**  
CWANA price includes carriers, pulleys, endstops, hanging clamps, splice clamps and rope if necessary.

- Track will be sold in stock lengths only. If precise cutting is required, add 9.00 per cut.
- In most situations, extra track is needed to allow curtains to overlap in the middle.
- Track lengths greater than 8' must ship via common carrier.

**140 SERIES RIG-I-FLEX®**

RIG-I-FLEX is a versatile I-beam track which has been engineered for both curved (Model 140) and straight (Model 141) cord traverses as well as for "walk-along" (Model 142). It was designed for medium weight curtains on stages and TV studios and for enclosing areas in industrial plants. Overall track length should not exceed 60'. Model 140 utilizes spindles and idler brackets (not included in CWANA pricing) for guiding the operating cord along curved areas. The track is curved on-the-job or at the factory (at an additional price) to a minimum radius of 2'. Bending tools also available from Rose Brand. 1 carrier per foot is included in CWANA price.

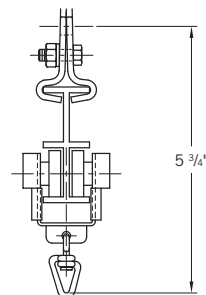

**140 CURVED TRACK SECTIONS**

Pre-curved track section with splice clamps.

1492	Approx. 2' x 2' 90°	Price 157.50
------	---------------------	-----------------

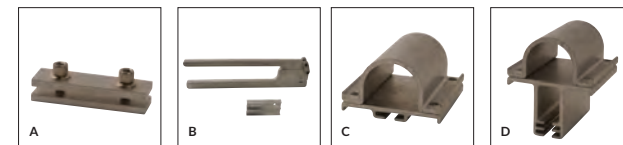

140 SERIES ACCESSORIES				
ITEM	ITEM/DESCRIPTION	ITEM NUMBER	COLOR	PRICE
A	<b>THE LIGHT SOURCE™ M140 TRACK SPLICE</b> A set of 2 aluminum bars for splicing 140 track together on walk-along systems. Back bar is tapped for the included hardware. Only 1/4" hex key is needed for installation. Use M140 Track Punch for proper hole placement.	HWTR0002	Black	5.90
		HWTR0001	Aluminum	5.90
B	<b>THE LIGHT SOURCE™ M140 TRACK PUNCH</b> Punches one hole in the end of 140 track for proper placement of the M140 Track Splice. Effortlessly provides over 1 ton of punching force!	HWTR0003	Aluminum	225.00
C	<b>THE LIGHT SOURCE™ MEGA-TRACK HANGER SHORT</b> Mounts your 140 series track 3/16" off the bottom of a batten or the bottom pipe of a pipe grid. Can be used perpendicular or parallel to the pipe. Hardware included.	HWME0012	Black	15.85
		HWME0011	Aluminum	15.85
D	<b>THE LIGHT SOURCE™ MEGA-TRACK HANGER LONG</b> Used to offset the distance between the top and bottom pipe when installing 140 track to the top pipe of a pipe grid. Can be used perpendicular or parallel to the pipe. Used in conjunction with the Mega-Track hanger short. Hardware included.	HWME0010	Black	15.85
		HWME0009	Aluminum	15.85

ADC 132/220/113 TRACK SELECTOR CHART						
TRADE NAMES METAL CONSTRUCTION AND SERIES	APPROX. MAX. CURTAIN WT. PER FOOT OF TRACK (LBS.)	MAX. TRACK LENGTH BI-PARTING	APPROX. CURTAIN STACKING SPACE PER LINEAR FT. TRACK	MODEL NO.	DIFFERENCES: TIRE/AXLE (SINGLE CARRIER PART NUMBER)	CWANA** PRICE PER FOOT
<b>132 SERIES FLEX-I-TRAC®</b> Aluminum Track (Can be curved - Call for Pricing)	6.5	Any	1"	132	Nylon (1301 Walk-Along)	26.28
	6.5	Any	1"	132-A	Nylon/Self Lubricating (1301-A Walk-Along)	25.58
	13	Any	1"	132-B	Nylon/Ball-Bearing (1337 Walk-Along)	28.47
	3	Any	1"	132-C	Nylon/Ball-Bearing (1337-A Walk-Along)	34.85
	13	26'	3.0"	220	Polyethylene (1701)	39.62
<b>220 SERIES TRAK-EZE®</b> Aluminum Track	13	32'	1.5"	220-N	Nylon/Ball-Bearing (2201)	42.88
	4	20'	2.5"	113	Polyethylene (1131)	28.78
<b>113 SERIES SPECIFINE®</b> Aluminum Track	4	20'	2.5"	113-W	Polyethylene (1131 Walk-Along)	21.92

**\*\*CWANA: Complete With All Necessary Accessories.**  
CWANA price includes carriers, pulleys, endstops, hanging clamps, splice clamps and rope if necessary.

- Track will be sold in stock lengths only. If precise cutting is required, add 9.00 per cut.
- In most situations, extra track is needed to allow curtains to overlap in the middle.
- Track lengths greater than 8' must ship via common carrier.

**132 SERIES FLEX-I-TRAC® (WALK-ALONG ONLY)**

FLEX-I-TRAC is a light-to-medium duty cyclorama I-beam type track designed for light to medium weight stage and TV studio curtains, and for enclosing industrial welding booths. This economically priced track unit is supplied for "walk-along" operation only, with no cord, pulleys, or master carriers. The track can be curved on-the-job (or at the factory at an additional price) to virtually any degree on a 2' minimum radius. For the most satisfactory track operation, the track should be solidly anchored to the ceiling with ceiling clamps. Bending tools also available from Rose Brand. 1 carrier per foot is included in CWANA price.

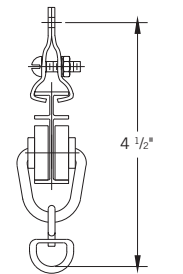

**132 CURVED TRACK SECTIONS**

Pre-curved track section with splice clamps.

1392	Approx. 2' x 2' 90°	Price 115.50
------	---------------------	-----------------

**220 SERIES TRAK-EZE®**

TRAK-EZE track is an ideal commercial duty curtain track for straight traverse installations of 26 feet or less, where it is important that the cord be completely concealed in the track and that the track be mounted directly to the ceiling structure. The track has a low profile and is aesthetically appealing while still providing the strength needed for moderately sized curtains. 2 carriers per foot for 220; 1 carrier per foot for 220N.

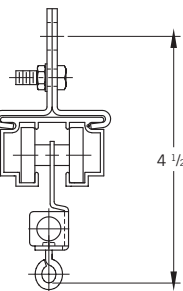

**113 SERIES SPECIFINE®**

SPECIFINE Model 113 is an aluminum box-shaped curtain track especially designed to meet architectural specifications for straight traverses up to 20' in length. Classrooms, residences, board rooms, multi-purpose rooms, cafeterias, churches, hotels, and banks are all ideal applications for the Model 113 Specifine track. 2 carriers per foot are included in CWANA price.

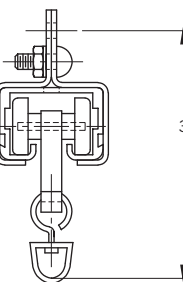

Fabrics  
Black Masking  
Custom Stage Curtains & Backdrops  
Custom Special Event Sewing  
Digital Printing  
LED Star Drops  
Pipe & Base  
Rentals  
Projection Materials  
Flooring  
Curtain Track  
Stage Equipment, FXs & Mirrors  
DMX Winches  
Scenery Props  
Shop & Production Supplies  
Tape  
Film & Video Supplies  
Index



# ADC Curtain Track Motors & Controllers



DRAW CURTAIN MOTOR SELECTOR GUIDE										
	BRAND	MODEL NO.	HP	POWER REQUIRED	ROPE SPEED	TYPE	MAX ROPE TRAVEL (IN FEET- ONE WAY)	MOUNT	TRACK TYPE	PRICE
A	ADC	2928	½	120v - 1 Phase - 8.8 Amp 220v- 1 Phase - 4.4 Amp	45 or 90 ft/min	Friction Drive	Unlimited	Track/Ceiling/Wall	280 Series	4,963.54
A	ADC	2917	½	120v - 1 Phase - 8.8 Amp 220v- 1 Phase - 4.4 Amp	45 or 90 ft/min	Friction Drive	Unlimited	Track/Ceiling/Wall	170 Series	4,832.45
B	ADC	934	¼	120v - 1 Phase - 5.8 Amp 220v- 1 Phase - 2.9 Amp 230v- 3 Phase - 2.0 Amp	86 ft/min	Grooved Drum	45	Floor	Any	4,499.64
C	ADC	2904TV	½	120v - 1 Phase - 10.0 Amp 220v - 1 Phase - 5.0 Amp 230v - 3 Phase - 2.0 Amp	0 to 86 ft/min	Grooved Drum	90	Floor	Any	8,196.79
D	ADC	2960	½	120V - 1 Phase - 10 Amp	90 ft/min	Friction Drive	Unlimited	Floor	140, 170, 280, 500 Series	4,979.48
D	ADC	2962	½	120V - 1 Phase - 10 Amp	45 ft/min	Friction Drive	Unlimited	Floor	140, 170, 280, 500 Series	5,032.05



**ADC LOGISTOP™**  
Logistop is a programmable multi-stop limit switch that can provide 2 to 20 preset stops on virtually any type of rotating machinery. Simple, push button programming is as easy as programming a preset on your car radio. Comes with DMX signal control capabilities.

**Model Number** LS-1      **Price** 3,079.45

MODEL NO LS-1 LogiStop®	
Input Power Source	120/220 Vac
Control Voltage	24 Vdc
Remote Input Type	Normally open momentary operation
Output Relay Rating	2 A at 250 Vac
Maximum Number of Stops	20
Minimum Number of Stops	2
Number of Allowable Remotes	Unlimited
Maximum Encoder RPM	40*
Mechanical Limit Switch Rating	20 A at 125 Vac

\*Precision of the LogiStop® is affected by the speed of the machines as well as the diameter of the machine's final output device, (such as a grooved drum or wheel.) The larger the diameter of these devices, the less accurate the stop positioning will be.

# ADC Curtain Track Wall Brackets



Products: ADC 132 Series FLEX-I-TRAC, 1483INV Wall Bracket and 15 oz. Encore Masking; Holton-Arms School – Large Dance Studio; Designer: Mark Robinson; Scene Shop: Holton-Arms School; Photo: Liz Goldman

### ADC™ WALL BRACKETS



**ADC™ MODEL 1483UNI WALL BRACKET**

This wall bracket can be used to wall mount the entire line of ADC track systems. A slotted mounting surface allows the tracks to be easily adjusted from 4" to 12" from the mounted wall. The bracket is designed to work with bi-parting or one-way draw track systems. Fabricated from ½" steel with a black powder coated finish.

Overall Dimensions 14 13/16" L x 14" H x 1 1/2" W

**Price** 70.65



**ADC™ MODEL 1483INV WALL BRACKET**

Same benefits as the 1483UNI bracket, but it allows the tracks to be mounted closer to the ceiling and hides the bracket from view when the curtain is closed.

**Price** 62.07



**ADC™ MODEL 1383UNI WALL BRACKET**

Wall Bracket for smaller tracks, such as ADC Models 132, 113, and 220. Projection off the wall can be 8", 6", or 4". Fabricated from ½" steel with black powder coated finish.

**Price** 52.23

Fabrics  
 Black Masking  
 Custom Stage Curtains & Backdrops  
 Custom Special Event Sewing  
 Digital Printing  
 LED Star Drops  
 Pipe & Base  
 Rentals  
 Projection Materials  
 Flooring  
 Curtain Track  
 Stage Equipment, FXs & Mirrors  
 DMX Winches  
 Scenery Props  
 Shop & Production Supplies  
 Tape  
 Film & Video Supplies  
 Index



## Kirsch Track

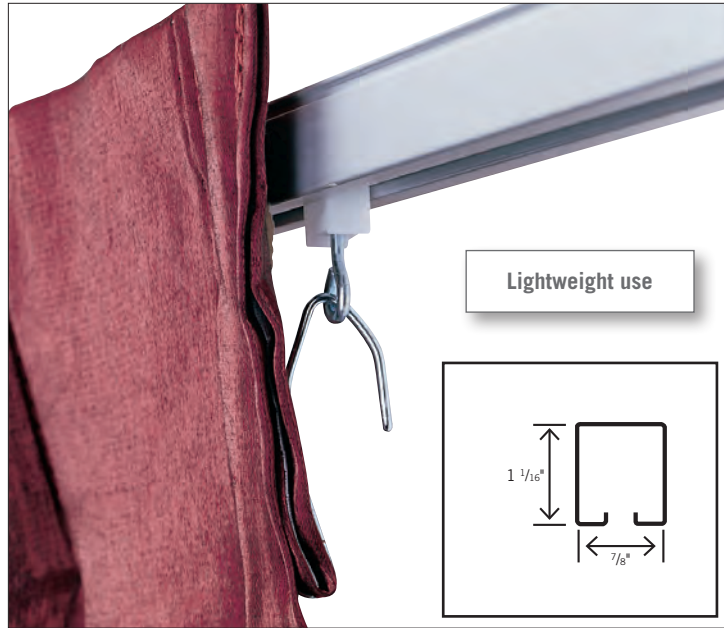

Lightweight use

### KIRSCH SERIES 9600

This low profile track is perfect for pinch pleated lightweight walk along window curtains up to 12' in height with a maximum of 2 lbs. per foot of width. Sold in 8' lengths shipping via UPS or 16' lengths shipping via truck, the track can be easily cut on location using traditional cutting tools.

The easy rolling metal shafted carrier won't bind or screech as it rolls through corners. Center ridge-grooved for easy installation.

Individual components such as brackets, carriers and flanges can be found on RoseBrand.com. Please call us at 1-800-223-1624 for information and expert advice. Installation assistance is also available.

	Price
8'	45.00
16'	80.00
30° x 30° 90° Bends*	40.00
*Custom curves available. Call for Pricing.	



Low-profile track is perfect for pinch-pleated, lightweight walk along window curtains.



## Rose Brand Custom Bending & Components

### Rose Brand Custom Bending

If you need curved track, why not get it from your track experts?

You have something else to bend? We can do that too! Pipe, square tubing and more!

We are excited about our new capabilities; we want you to be too.



Custom Bending

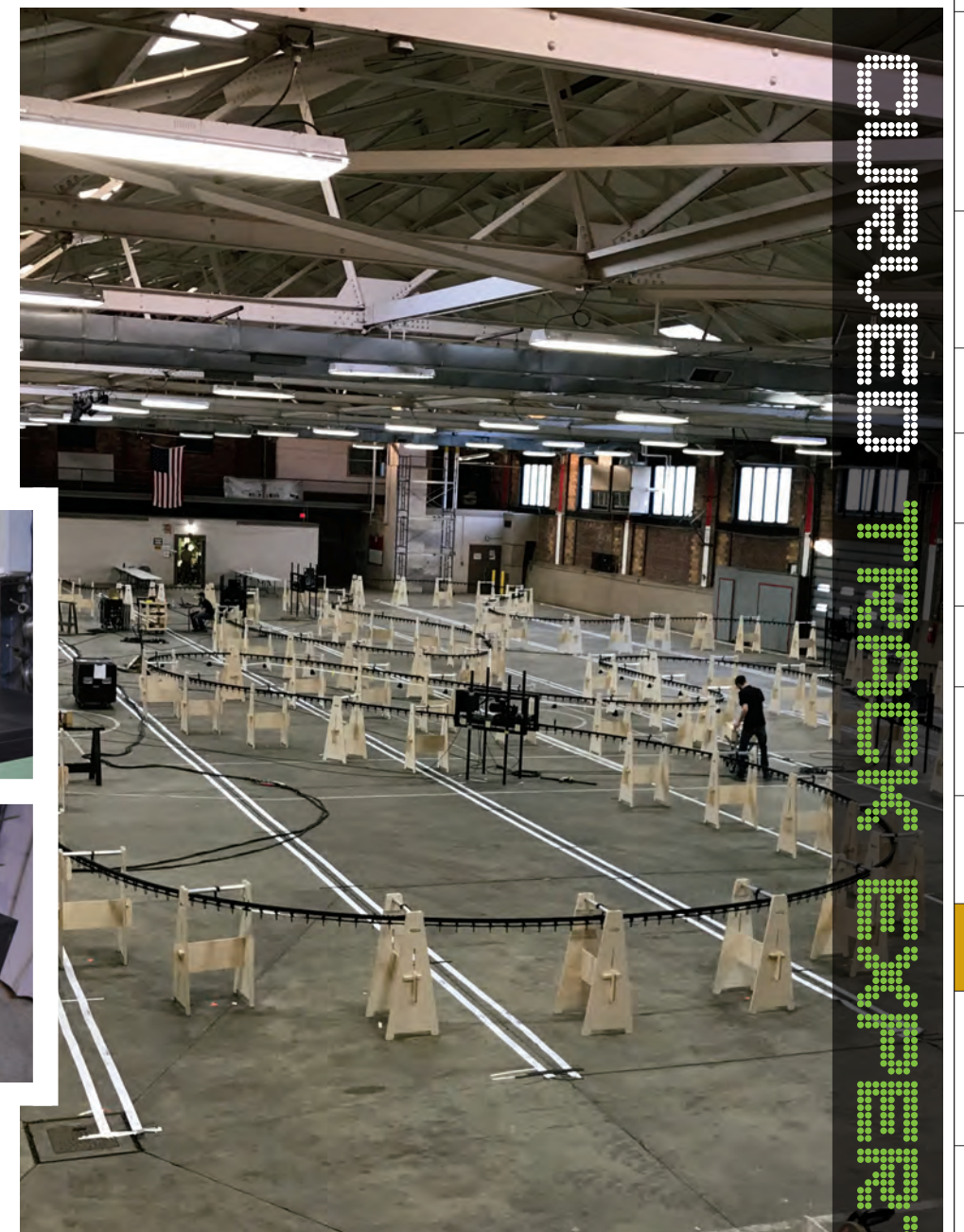

### Rose Brand Custom Components

Custom metal brackets and plates are no problem. We have the equipment and expertise to manufacture your parts when and how you need them, fast! Contact a Rose Brand Technical Sales associate to get a quote.



Manufacturing Custom Components



- Fabrics
- Black Masking
- Custom Stage Curtains & Backdrops
- Custom Special Event Sewing
- Digital Printing
- LED Star Drops
- Pipe & Base
- Rentals
- Projection Materials
- Flooring
- Curtain Track
- Stage Equipment, FXs & Mirrors
- DMX Winches
- Scenery Props
- Shop & Production Supplies
- Tape
- Film & Video Supplies
- Index



## Stage Rigging & Project Management

DESIGN  
TRAINING  
PROBLEM  
RESOLUTION  
INSTALLATION



## BEYOND FABRIC AND SEWING...

Most calls to Rose Brand begin with fabric, but they often end with a host of other solutions to make your project better, safer, and faster to install. All this adds up to peace of mind for you.

We offer a range of services that stretch well beyond the provision of fabric and the manufacture of curtains, including:

- Technical Project Management and Installation
- Site Survey, Inspection and Consultation
- Custom Rigging Solutions
- Motorization and Controls Design
- Parts and Component Fabrication
- Track, Pipe and Tube Bending



### Project Management and Installation

The Rose Brand Technical Department will work with your team to solve any hiccups that arise and ensure your project is installed on time and on budget.



### Site Survey, Inspection and Consultations

Rose Brand ETCP certified technicians will meet with you on-site and offer expert advice on the best solutions to improve the functionality and safety of your stage.



### Custom Rigging Solutions

Expert technicians work with you to design a solution that meets the precise needs of your space, schedule, and budget.



### Motorization and Controls Design

Choose controls easy enough for the maintenance department and sophisticated enough for a spectacular reveal on opening night. Options include custom screen for touch panels, build in key-controls, or integrated DMX into serial protocols.

## BACK-END TECHNICAL SOLUTIONS



### Track, Pipe, and Tube Bending

Let us make your life easier. Bending and rolling is available for both complete track systems and specific set components.

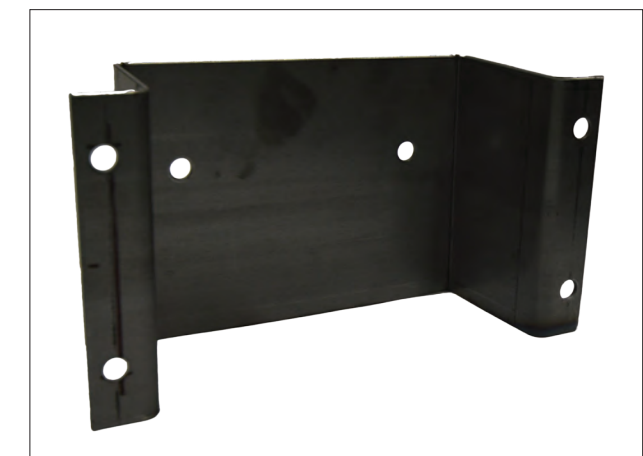

### Parts and Component Fabrication

Jigs, plates, mounts and other necessary widgets make scenery building easier, faster, and safer.

Fabrics
Black Masking
Custom Stage Curtains & Backdrops
Custom Special Event Sewing
Digital Printing
LED Star Drops
Pipe & Base
Rentals
Projection Materials
Flooring
Curtain Track
Stage Equipment, FXs & Mirrors
DMX Winches
Scenery Props
Shop & Production Supplies
Tape
Film & Video Supplies
Index



# Stage Equipment, FXs & Mirrors

- The Rose Brand Kabuki System .....294
- Snowmachine .....296
- DMX Scenery Rotator.....297
- Roll Drum.....298
- DMX Winches.....300
- DMX Equipment.....303
- SpanFrame™ .....304
- Glassless Mirrors.....306

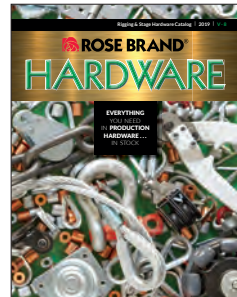

ORDER HARDWARE  
CATALOG ONLINE



**EVERYTHING YOU NEED IN  
PRODUCTION HARDWARE... IN STOCK**

- Fabrics
- Black Masking
- Custom Stage Curtains & Backdrops
- Custom Special Event Sewing
- Digital Printing
- LED Star Drops
- Pipe & Base
- Rentals
- Projection Materials
- Flooring
- Curtain Track
- Stage Equipment, FXs & Mirrors
- DMX Winches
- Scenery Props
- Shop & Production Supplies
- Tape
- Film & Video Supplies
- Index



# The Rose Brand Kabuki System

BUY OR RENT

Presentation is everything. Unveil your new product, event or performance.



CONCEAL

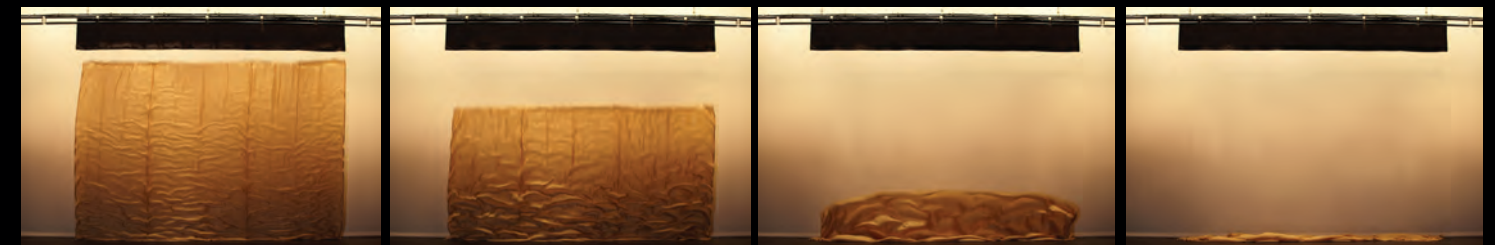

REVEAL



Product: 55' H x 220'W Kabuki Curtain, Allegro Silk, CES 2018 Keynote, MGM Park Theater, Designer: Todd Edward Ivins, Scene Shop: Mystic Scenic Studios, Photo: Brian Ach

The Kabuki drop is a special effect in which a lightweight fabric is dropped swiftly from above to conceal or reveal your product, space or performers. The Rose Brand Kabuki System is lightweight, modular and easy to employ. For even greater versatility, the Rose Brand Kabuki System is capable of both single and double kabuki effects.

The single Kabuki consists of either a concealing curtain dropping in (see photos above), or a revealing curtain dropping to the floor (see photos on page 277). The double Kabuki is a two-step process which begins with the curtain stored above, out of sight. The first trip releases the curtain into its concealing position. A second trip releases the curtain to the floor for the reveal.

Unlike other systems which require multiple trip mechanisms, the Rose Brand Kabuki System can operate a full stage single kabuki drop on just one trip mechanism. Add just one more for the double Kabuki effect.

► Go to Video at <http://bit.ly/kabuki-system> to see Kabuki in action

Shown here: The Rose Brand Kabuki System: Kabuki 5' Unit, Kabuki Trip Mechanism, and Kabuki Pendant Controller.

### KEY CHARACTERISTICS AND BENEFITS INCLUDE:

- Units can be triggered by your light board non-dim when available, or a pendant controller (sold separately)
- Manual trip cord provides fail safe
- Pendant controller operates single or double trip effect
- Units operate from 110 v power outlet and require less than 1 amp
- Using your light board and additional trip mechanisms, the Rose Brand Kabuki can be configured to create a "tear away" trip effect
- Modular design makes installation, removal and transport simple
- Units can be linked for large full stage curtains
- Durable black anodized finish
- Lightweight aluminum construction made in the USA
- Curtains hang on pins that adjust to your grommet spacing
- Each 5' unit is suspended from adjustable pipe clamps (included)

**Reliable, fail-safe operation so your Kabuki drops the first time and every time.**



### THE ROSE BRAND KABUKI SYSTEM

	Pricing
<b>Kabuki 5' Unit</b>	575.00
<b>Kabuki Trip Mechanism</b>	550.00
<b>Kabuki Pendant Controller</b>	1,375.00
<b>Kabuki Flight Case</b>	2,095.00
Holds up to six Kabuki units and accessories.	
<b>Kabuki in a Box System</b>	5,500.00
Everything you need for a single trip Kabuki in a durable flight case. You get six Kabuki units (enough for 30' drop), one Kabuki trip mechanism and room for additional accessories.	

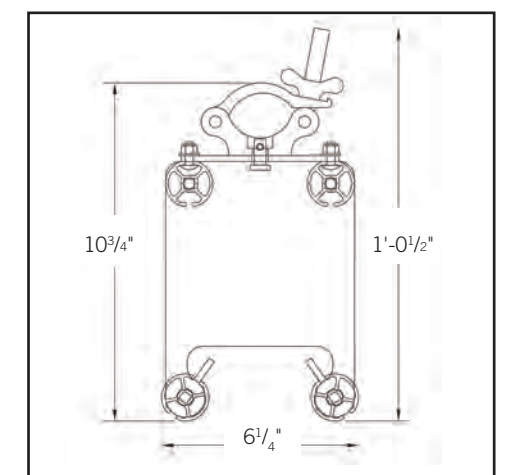

Kabuki System schematic

- Fabrics
- Black Masking
- Custom Stage Curtains & Backdrops
- Custom Special Event Sewing
- Digital Printing
- LED Star Drops
- Pipe & Base
- Rentals
- Projection Materials
- Flooring
- Curtain Track
- Stage Equipment, FXs & Mirrors
- DMX Winches
- Scenery Props
- Shop & Production Supplies
- Tape
- Film & Video Supplies
- Index



# Snow Machine



## SNOWSTAR

The SnowStar is a motorized, rotating, perforated aluminum tube that provides snow & confetti effects from a dusting to a blizzard. Multiple 5' long drums with a diameter of 8" can connect together to create the desired stage length. One motor drives 1 to 16 connected 5' sections. The classic tumbler has 3/8" perforations, and uses Paper Snow or Confetti for the ultimate effect. The square tumbler has a 1" x 1" opening.

	Price
Clamp & Bearing	70.00
8" x 5' Classic Tumbler (3/8" holes)	687.50
8" x 5' Square Tumbler (1" square openings)	900.00
Motor Unit	1,175.00



## FR SNOW

Loose, white snowflakes. Also available in plastic flakes.

	Price
FR Plastic Snow - 25 lb. Box	150.00
FR Paper Snow - 25 lb. Box	330.00

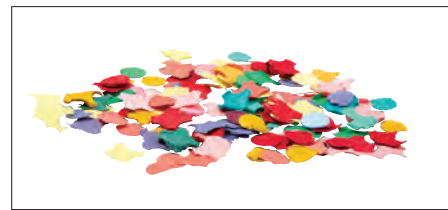

## FR PAPER CONFETTI

A mixed assortment of loose, colorful, paper confetti in various sizes from 3/16" to 7/16". Mixed 25 lb. box includes yellow, orange, pink, red, blue, green, light yellow, teal, and dark green.

	Price
FR Paper Confetti - 25 lb. Box	265.00

Jimmy Fallon performs "Snowball" with the Rose Brand Snow Machine providing the effects.



► Go to Video at <http://bit.ly/theatrical-snow-machine>



One motor drives 1 to 16 connected 5' sections!

# DMX Scenery Rotator

Use the DMX Scenery Rotator virtually anywhere you need simple but precise motorized control of a spinning set piece. Consider it for moving clock hands, rotating signs, motorized window or door pivots, advanced mirror ball effects, periaktoi, rotating mirror panels, or anything else that a designer imagines. Can be mounted vertically or horizontally, and is operated via a DMX controller.



## DMX SCENERY ROTATOR

DMX Controlled Rotator  
Part No. WAHL0010  
**\$1,450.00**

### Benefits

- Heavy duty construction allows for rotating larger set pieces.
- DMX cues can create precise and repeatable rotation and positioning effects
- Versatile for a wide range of effects with both vertical and horizontal mounting options

### Specifications

- 50 Kg (110 lbs) load limit on vertical mount
- 10 Kg (22 lbs) load on horizontal mount
- 20 mm (0.79 in) x 100 mm (4 in) output shaft with 10 mm internal thread
- 1-12.5 rpm
- Torque = 10Nm
- 5-pin DMX input and pass through
- 6 Channels of DMX control
- 16-bit DMX precision
- PowerCon™ TRUE1 input and pass thru
- 120VAC input, 75 watt consumption
- Optional 208/240VAC
- 5.2 x 9.2 x 7.2 in; 13 lbs.



The DMX Scenery Rotator LX opens up a world of FX possibilities. In addition to precise control of speed, direction and stopping position of the motorized shaft, the new LX model can pass both power and data to the set piece or equipment connected to the Scenery Rotator. Considering rotating lighting practicals, electrified set pieces, small prop and retail turntables (with power and data!), or even creating effects such as passing head lights. The uses in theatre, exhibit design and visual merchandising are endless.



## DMX SCENERY ROTATOR LX

With power and data pass through  
Part No. WAHL0023  
**\$2,125.00**

### Benefits

- Pass power and data through the rotator shaft
- Safe, repeatable and accurate positioning and limit settings
- Build complex programmed effects and set pieces quickly and easily
- Easy to use in any environment
- Versatile applications from simple spinning to sophisticated cues

### Specifications

- 150 Kg (330 lbs) load limit on vertical mount
- 50 Kg (110 lbs) load on horizontal mount
- 0.15 - 6.8 rpm
- Torque = 10Nm
- 5-pin DMX input and pass through
- 6 Channels of DMX control
- 8- or 16-bit DMX precision
- PowerCon™ TRUE1 input and pass thru
- 4 conductor SA, 300 V MAX on pass through
- 10.2 x 7.0 x 12.5 in; 26 lbs.



Fabrics  
Black Masking  
Custom Stage Curtains & Backdrops  
Custom Special Event Sewing  
Digital Printing  
LED Star Drops  
Pipe & Base  
Rentals  
Projection Materials  
Flooring  
Curtain Track  
Stage Equipment, FXs & Mirrors  
DMX Winches  
Scenery Props  
Shop & Production Supplies  
Tape  
Film & Video Supplies  
Index



## Roll Drums

With the new DMX Roll Drum, classic roll drop technology has been reinvented to make it easier to operate, faster to install, and drastically more affordable. Powerful AC motors with 16-bit DMX encoders are located inside the roll drum itself. Hanging the drum is simply a matter of mounting the half-clamps to your pipe, truss or overhead points. Provide power and DMX and the installation is complete. No drive chains, limit boxes, or other gadgets to connect. Roll drums as wide as 40 foot can be easily configured. Call for pricing.



### DMX ROLL DRUM

Internally Motorized Roll Drum  
Price on request

#### Benefits

- Fast and easy mounting with no chains or limit boxes to install and tension
- High speed operation for fast scene changes
- Quickly configure multiple limit positions using precise 16-bit DMX control
- Internal motor eliminates bulky drive boxes for a smaller profile and cleaner look
- Mount multiple units end to end with minimal wasted space
- Sleeved drum mechanics configures to the size needed for your space

#### Specifications

- Drum Dimensions: 8in diam x 39ft (max)
- 35 Kg (77 lb) lifting capacity
- 39 in/sec. max speed
- Max lifting height 49ft (59ft optional)
- 5-pin DMX input and pass through
- 6 Channels of DMX control
- 16-bit DMX precision
- PowerCon™ TRUE1 input and pass thru
- 208VAC input, 500 watt consumption
- 12.5 x 13.9in motor and idle bracket

**wahlberg**  
MOTION DESIGN



## Roll Drums

For permanent installation in venues such as concert halls, auditoriums and conference centers, Rose Brand Motorized Roll Drums can be designed to the specifications of your space and your needs. Using an 8in diameter aluminum tube, mechanisms from 6ft to 38ft wide can be built – two sections spliced together for lengths greater than 24ft.

Control is via a simple push-button station, though additional options are available including key operation, wireless remote, dry-contacts or an advanced programmable touch screen. Contact Rose Brand to discuss the needs of your installation.

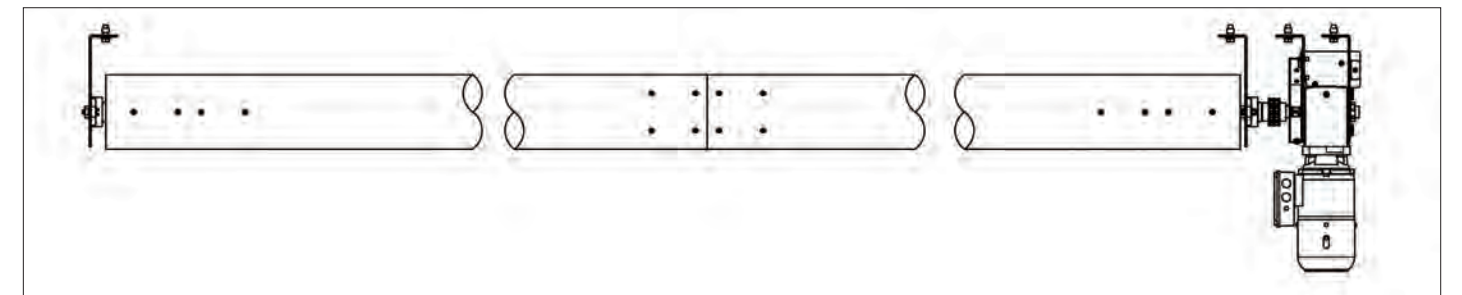

The DMX Mini Roll Drum can be easily built into scenery, retail windows, or architectural environments to provide a roll up solution for window blinds, draperies, projection screens or printed banners.

DMX control of speed, direction and positioning means easy configuration with unlimited programming options – even remote location control for broadcast studios.



### HEAVY DUTY DRUM

Custom Roll Drum  
Price on request

#### Benefits

- Custom Roll Drum available up to 38 feet wide with tube splices for easy shipping and storage. Mount the roll drum and motor using pipe clamps or threaded rod.

#### Specifications

- Push Button Control Station included; Additional control options include key operated station, wireless remote, dry contacts, or touch screen
- Lifting Capacity: 120 lbs.
- Lifting Height: 49 feet
- Variable Speed: 30 in/sec
- 120 V Single Phase 60 hz
- Variable Frequency Drive

### DMX MINI ROLL DRUM

Price on request

#### Benefits

- Compact design easily fits into scenic, retail or architectural environments
- Easily customized to the specific needs of your project
- Fits into many scenic or architectural configurations
- Saves time and can easily adjust speed, limits and trims from the control desk

#### Specifications

- 7 Kg (15 lb) lifting capacity
- 10in per sec. max speed
- 3ft - 12ft custom lengths
- 3in Aluminum tube
- 5-pin DMX input and pass through
- 6 Channels of DMX control
- 16-bit DMX precision
- Powercon™ TRUE1 input and pass thru
- 120VAC input, 150 watt consumption
- 5.9" x 8.9" x 3.5" motor box

**wahlberg**  
MOTION DESIGN



# DMX Winches



Wahlberg Winches come in sizes from 1Kg up to a powerful 50Kg load rating. Simple to operate via DMX. This family of winches is perfect for providing fast and easy light-duty scenery automation using DMX to set position and trim points, write movement cues, or create stunning motion "choreography." Use multiple winches to create a fully automated contour curtain, where each lift line in the drape is controlled independently and can be programmed to different looks via DMX console.

A variant of the Winch 10, the Winch 10 LX allows electrical power and data to be run down the lifting cable enabling you to electrify the element being hung, such as a chandelier, lighted sign, or moon box. The Wahl Winches are not intended for use hoisting line sets or other critical and load-bearing rigging elements.

A variant of the Winch 10, the Winch 10 LX allows electrical power and data to be run down the lifting cable enabling you to electrify the element being hung, such as a chandelier, lighted sign, or moon box. The Wahl Winches are not intended for use hoisting line sets or other critical and load-bearing rigging elements.



Thirty-one (31) Winch 10LX were used to create the matrix of naked light bulbs which flew in and out of scenes in Mimi Lien's set for *Natasha, Pierre and the Great Comet of 1812*. Rose Brand's 16 oz Cherry Princess Velour; Scenic Design: Mimi Lien; Scene Shop: Hudson Scenic; Photo: Chad Batka

### WINCH COMPARISON CHART

ITEM	MIN. LOAD	LOAD CAPACITY	TRAVEL SPEED	INPUT VOLTAGE	SIZE IN INCHES (L-W-H)	WEIGHT	NOTES
WINCH 1	0.6 Kg (1.3 lbs.)	1 Kg (2.2 lbs.)	5-60 in/sec	120v or 230v	5.1 x 10.1 x 14.1	13.2 lbs.	Fastest retraction speed.
WINCH 5	1 Kg (2.2 lbs.)	5 Kg (11 lbs.)	2-22 in/sec	120v or 230v	9.5 x 8.3 x 5.19	11.5 lbs.	Twice as fast as Winch 10.
WINCH 10	1 Kg (2.2 lbs.)	10 Kg (22 lbs.)	5-12 in/sec	120v or 230v	9.5 x 8.3 x 5.19	11.5 lbs.	Perfect for rigging lightweight drapes.
WINCH 10 LX	2.5 Kg (5.5 lbs.)	10 Kg (22 lbs.)	5-12 in/sec	120v or 230v	9.5 x 15.5 x 5.8	18.5 lbs.	Powered cable provides 5A of power and data to suspended unit.
WINCH 25	1 Kg (2.2 lbs.)	25 Kg (55 lbs.)	2-16 in/sec	208v / 230v	15.7 x 8.9 x 11.4	46 lbs.	For medium duty loads with high speeds.
WINCH 25 X2	1 Kg (2.2 lbs.)	25 Kg (55 lbs.)	2-16 in/sec	208v / 230v	27 x 8.9 x 14.25	55 lbs.	Dual cable picks prevent element from rotating while raising or lowering.
WINCH 50	3.5 Kg (7.7 lbs.)	50 Kg (110 lbs.)	3.5-18 in/sec	208v / 230v	12.9 x 11.7 x 17.5	66 lbs.	For heavier loads at lower speeds.

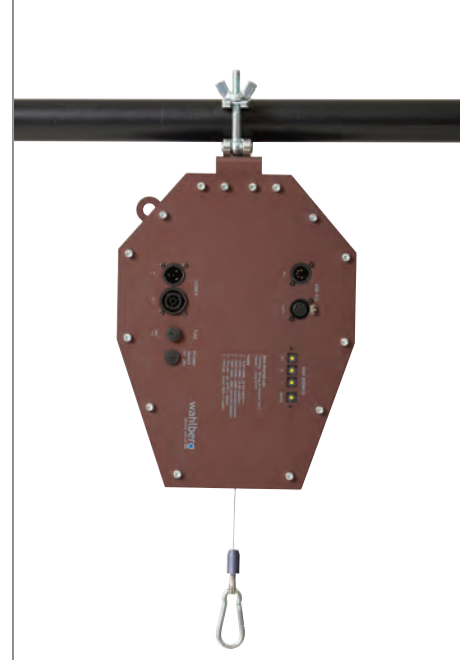

#### WINCH 1

Light Duty, Fast DMX Winch  
Part No. WAHL0001  
**\$1,350.00**

Perfect for small fast pick-ups of fabrics or other special effects. The extra large take up reel makes this compact cable winch the fastest in our range, running at 60 in / sec. Suitable for lightweight loads up to a 1 Kg (2.2 lbs).

#### Benefits

- Fastest cable speed.
- Small form factor allows the winch to be mounted practically anywhere.
- Create quick grab gags and other fabric effects needing fast retraction.
- Precise and repeatable positions and limits easily set via 16-bit DMX.

#### Specifications

- 1.2 Kg (2.5 lbs) working load limit (min. load 0.6 Kg (1.3 lbs))
- 5 - 60 inch/sec. speed
- 40 ft lifting height (50 ft optional)
- 2 mm (3/32 in) 7 x 7 strand aircraft cable
- 5-pin DMX input and pass through
- 7 Channels of DMX control
- 16-bit DMX precision
- PowerCon™ TRUE1 input and pass thru
- 120VAC / 230VAC switchable
- 5.1 x 8.9 x 14.1 inches; 13.2 lbs



#### WINCH 5

Light Duty, Fast DMX Winch  
Part No. WAHL0002  
**\$1,595.00**

A compact cable winch with a 5 Kg (11 lb) load limit which can be easily controlled via DMX from a lighting desk or stand-alone controller.

#### Benefits

- Twice as fast as Winch 10.
- Small form factor allows the winch to be mounted practically anywhere.
- Easily automate scenic moves without dedicated battens and rigging systems.
- Precise and repeatable positions and limits easily set via 16-bit DMX.

#### Specifications

- 5 Kg (11 lbs) working load limit (min. load 1 Kg (2.2 lbs))
- 2 - 22 inch/sec. speed
- 33 ft lifting height (50 ft optional)
- 2 mm (3/32 in) 7 x 7 strand aircraft cable
- 5-pin DMX input and pass through
- 7 Channels of DMX control
- 16-bit DMX precision
- PowerCon™ input
- 120VAC / 230VAC switchable
- 9.5 x 8.3 x 5.19 inches; 12 lbs



#### WINCH 10

Light Duty, DMX Winch  
Part No. WAHL0003  
**\$1,595.00**

A compact cable winch with a 10 Kg (22lb) load limit which can be easily controlled via DMX from a lighting desk or stand-alone controller.

#### Benefits

- Small form factor allows the winch to be mounted practically anywhere.
- Easily automate scenic moves without dedicated battens and rigging systems
- Precise and repeatable positions and limits easily set via 16-bit DMX

#### Specifications

- 10 Kg (22 lbs) working load limit (min. load 1 Kg (2.2 lbs))
- 2 - 12 inch/sec. speed
- 33 ft lifting height (50 ft optional)
- 2 mm (3/32 in) 7 x 7 strand aircraft cable
- 5-pin DMX input and pass through
- 7 Channels of DMX control
- 16-bit DMX precision
- PowerCon™ TRUE1 input
- 120VAC / 230VAC switchable
- 9.5 x 8.3 x 5.19 inches; 12 lbs



#### WINCH 10 LX

Light Duty, DMX Winch  
Part No. WAHL0005  
**\$2,295.00**

Useful in any situation where you need to provide power to a scenic element that is being flown. The Winch 10 LX combines a light duty load rating with an integrated electrical circuit in the lifting line. Perfect for eliminating the mess created by having to rig secondary electrical circuit.

#### Benefits

- Seamlessly provide power and data control to scenic elements
- Small form factor allows the winch to be mounted practically anywhere.
- Easily automate scenic moves without dedicated battens and rigging systems
- Precise and repeatable positions and limits easily set via 16-bit DMX

#### Specifications

- 10 Kg (22 lbs) working load limit (min. load 2.5 Kg (5.5 lbs))
- 2 - 12 inch/sec. speed
- 33 ft lifting height
- Kevlar jacketed lifting cable with integrated 4-circuit
- Grooved drum for quiet, kink-free cable wrapping
- 5-pin DMX input
- 7 Channels of DMX control
- 16-bit DMX precision
- PowerCon™ TRUE1 input
- 120VAC / 230VAC switchable
- Accessory Power: 300V, 5A max.
- 15.75 x 11.8 x 11.8 inches; 22 lbs

Now with  
4 circuit lifting cable  
for power and data  
connections

- Fabrics
- Black Masking
- Custom Stage Curtains & Backdrops
- Custom Special Event Sewing
- Digital Printing
- LED Star Drops
- Pipe & Base
- Rentals
- Projection Materials
- Flooring
- Curtain Track
- Stage Equipment, FXs & Mirrors
- DMX Winches
- Scenery Props
- Shop & Production Supplies
- Tape
- Film & Video Supplies
- Index



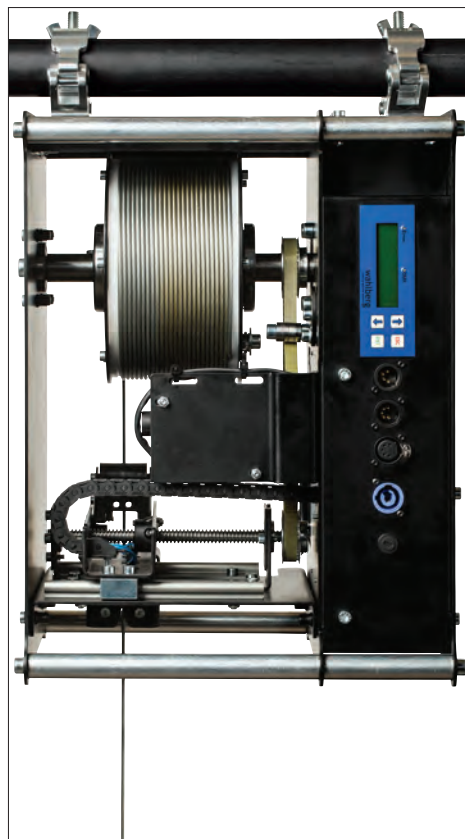
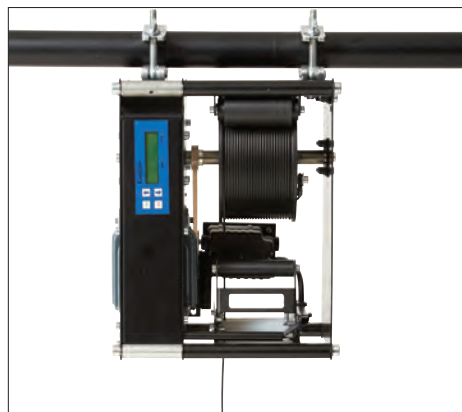

**WINCH 25**

Med Duty DMX Winch  
Part No. WAHL0006

**\$4,775.00**

A compact cable winch with a 25 Kg (55 lb) load limit which can be easily controlled via DMX from a lighting desk or stand-alone controller.

**Benefits**

- Compact yet powerful winch offers maximum versatility for rigging solutions
- Easily automate scenic moves without dedicated battens and rigging systems
- Precise and repeatable positions and limits easily set via 16-bit DMX

**Specifications**

- 25 Kg (55 lbs) working load limit (min. load 1 Kg (2.2 lbs))
- 2 - 16 inch/sec. speed
- 33 ft lifting height (50 ft optional)
- 2 mm (3/32) in 7x7 strand aircraft cable
- 5-pin DMX input and pass through
- 6 Channels of DMX control
- 16-bit DMX precision
- PowerCon™ TRUE1 input
- 208/240VAC input, 300 watt consumption
- 15.7 x 8.9 x 11.4 inches; 46 lbs

**WINCH 25 X2**

Dual Cable Med Duty DMX Winch  
Part No. WAHL0008

**\$5,475.00**

Uses two active lift lines to maintain a set piece in a plane, eliminating any rotation or sway while in motion. Like the rest of the Wahlberg Winch series, the Winch 25 X2 is compact enough to fit comfortably in a grid, attach to small truss, or mount to ceiling points while still providing 25 Kg (55 lbs) of lift. With its unique 2 wire configuration, this winch offers an easy solution to flying in all types of scenic elements that need to maintain their proper orientation while flying.

**Benefits**

- Unique 2 wire configuration prevents scenery from rotating while flying in or out
- Compact yet powerful winch offers maximum versatility for rigging solutions
- Easily automate scenic moves without dedicated battens and rigging systems
- Precise and repeatable positions and limits easily set via 16-bit DMX

**Specifications**

- 25 Kg (55 lbs) working load limit (min. load 1 Kg (2.2 lb))
- 2 - 16 inch/sec. speed
- 33 ft lifting height (50 ft optional)
- 2 mm (3/32 in) 7x7 strand aircraft cable
- 5-pin DMX input and pass through
- 6 Channels of DMX control
- 16-bit DMX precision
- Powercon™ TRUE1 input
- 208/240VAC input, 300 watt consumption
- 9 x 9.8 x 13.8 inches; 70 lbs

**WINCH 50**

Med Duty DMX Winch  
Part No. WAHL0007

**\$6,575.00**

The strongest winch in the Wahlberg range. The Winch 50 maintains a compact form while providing 50Kg (110 lb) of lifting strength. Working alone or configured together, the Winch 50 can be used for flying dimensional set pieces or rigging heavier weight drapery fabrics. DMX control makes setting positions and limits quick and easy, and complex motion cues can be written and recalled with ease.

**Benefits**

- Compact yet powerful winch offers maximum versatility for rigging solutions
- Easily automate scenic moves without dedicated battens and rigging systems
- Precise and repeatable positions and limits easily set via 16-bit DMX

**Specifications**

- 50 Kg (110 lbs) working load limit (min. load 3.5 Kg (7.7 lb))
- 3.5 - 18 inch/sec. speed
- 49 ft lifting height (75 ft optional)
- 3 mm (1/8 in) 7 x 19 strand aircraft cable
- 5-pin DMX input and pass through
- 6 Channels of DMX control
- 16-bit DMX precision
- Powercon™ TRUE1 input
- 208/240VAC input, 550 watt consumption
- 17.3 x 11 x 11.8 inches; 55 lbs

The DMX Lifting column is a simple solution for building a lightweight lift into scenery or props or for use in stage lighting rigs. Easily controlled via any DMX Console, multiple DMX Columns can be daisy chained together to quickly build complex choreography of moving elements.

A rugged base plate and versatile top cap make it easy to tech the DMX Lifting column into any set design. Or, mount moving lights and create even more dynamic lighting effects by raising and lowering the lights via DMX. Can be mounted vertically or horizontally, but not intended to LOWER loads, only lift.



**DMX COLUMN LIFT**

Part No. WAHL0029  
**\$1,775.00**

**Benefits**

- Easy to design into your scenery and quick installation
- Eliminates the complexity of building a "home-made" controller, easily operated from any DMX console
- Plug into any wall outlet
- Easily adapted to the needs of your set piece
- Versatile and reliable positioning control

**Specifications**

- 60 Kg (132 lbs) load limit on vertical mount
- 10 Kg (20 lbs) load on horizontal mount
- Travel speed: 0 - 2"/sec
- Travel height: 38" (32" - 70" overall)
- 5 Channels of DMX control
- 8- or 16-bit DMX precision
- Powercon™ TRUE1 input and pass thru
- 120VAC input, 150 watt consumption
- 7 x 11.7 x 32 in; 27 lbs.



A motor to solve the most annoying small problems in scenery and prop construction – how to motorize small scenic elements and control them easily and affordably.

The Mini Motor DMX is a compact, powerful DC motor in a finished enclosure for easy mounting. A spline shaft makes connecting everything from gears and pulleys to spiders and shaft collars simple. Six channels of 16-bit DMX control adjust speed and direction of the motor as well as providing accurate and reliable limits and positioning. The possible applications are limitless.

**DMX MINI MOTOR**

DMX Mini Motor  
Part No. WAHL0025  
**\$1,850.00**

**Benefits**

- Easy to design into your scenery and quick installation
- Eliminates the complexity of building a "home-made" controller, easily operated from any DMX console
- Plug into any wall outlet
- Easily adapted to the needs of your set piece
- Versatile and secure positioning control

**Specifications**

- 10 mm spline shaft
- 6-60 rpm
- Torque = 6.8Nm
- 5-pin DMX input and pass through
- 6 Channels of DMX control
- 8- or 16-bit DMX precision
- Powercon™ TRUE1 input and pass thru
- 120VAC input, 150 watt consumption
- 3.5 x 5.9 x 8.8 in; 9.6 lbs.

Fabrics
Black Masking
Custom Stage Curtains & Backdrops
Custom Special Event Sewing
Digital Printing
LED Star Drops
Pipe & Base
Rentals
Projection Materials
Flooring
Curtain Track
Stage Equipment, FXs & Mirrors
DMX Winches
Scenery Props
Shop & Production Supplies
Tape
Film & Video Supplies
Index



# SpanFrame™

A modular structural extrusion system to simplify the design and construction of open frames and 3D shapes in stage and event production.

SpanFrame™ is a custom aluminum extrusion designed for quick construction of structural frames and shapes. The unique profile can span up to 20 feet with minimal deflection and is tooled to accept a wide variety of connection hardware, including industry-standard strut nuts. Easy to splice, corner, connect and attach, the possibilities for using SpanFrame™ are virtually limitless.

Below photo shows our projection screens supported by our SpanFrame. Note that the forward image shows what the **front** looks like and the image in back shows what the **back** of the frame looks like - thicker, more evident.



**SPANFRAME™**  
Rectangular Frame with Projection Screen (rear view)

Works great with projections screens and digital prints.

Provides structure for:  
Tables, floors, walls and more

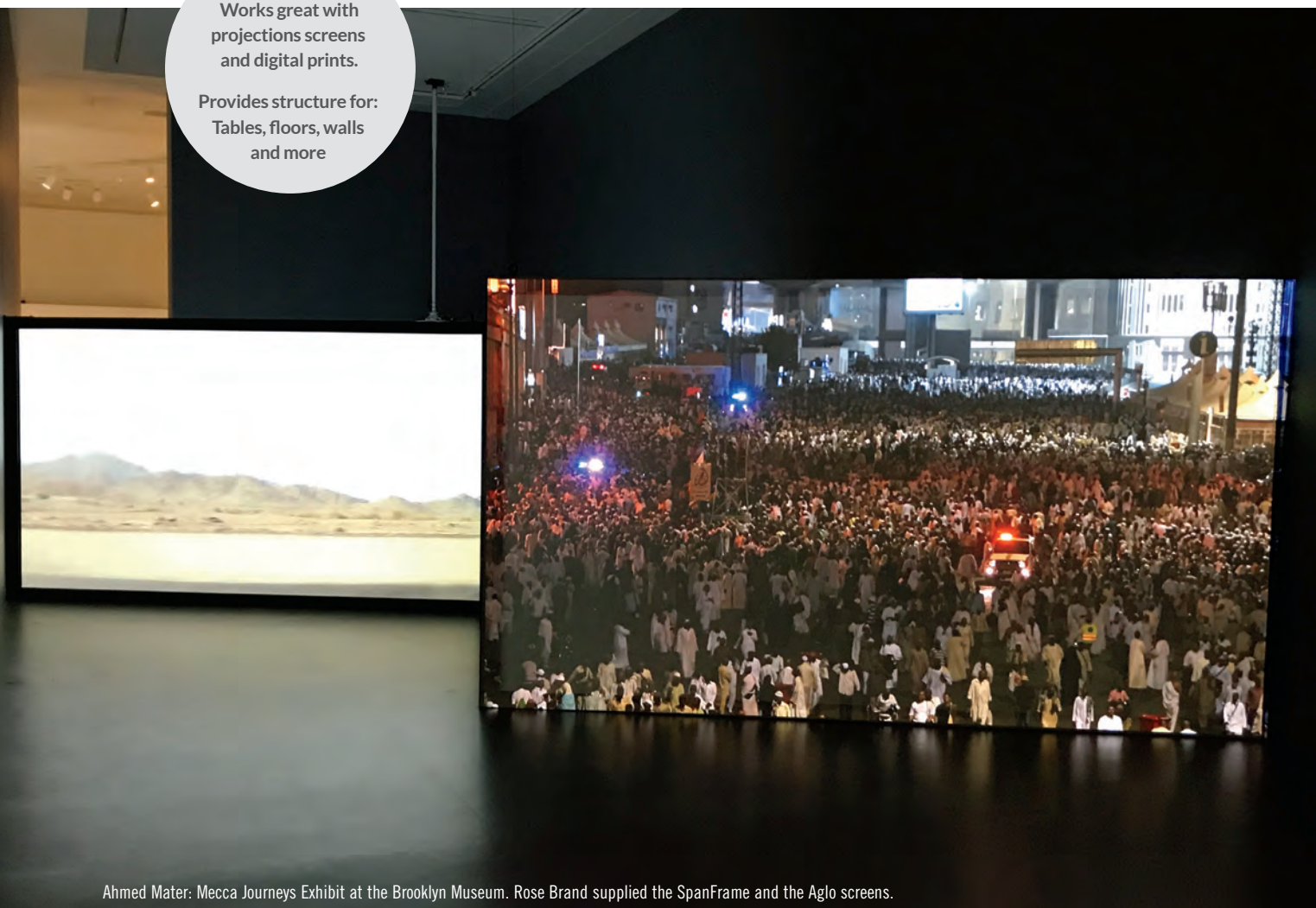

Ahmed Mater: Mecca Journeys Exhibit at the Brooklyn Museum. Rose Brand supplied the SpanFrame and the Aglo screens.

# SpanFrame™

FEATURES	BENEFITS	<p>Section View of Extrusion.</p>
<ul style="list-style-type: none"> <li>Robust 2" x 4" custom profile of high-strength aluminum.</li> </ul>	<ul style="list-style-type: none"> <li>Long spans without internal support means no shadows or obstructions.</li> <li>Suitable for stages, tables, and scenic elements.</li> <li>Clean elegant look fits in retail or architectural environments.</li> </ul>	
<ul style="list-style-type: none"> <li>Machined for strut-nut attachment on all 4 sides.</li> </ul>	<ul style="list-style-type: none"> <li>Easy to attach whatever is needed.</li> </ul>	
<ul style="list-style-type: none"> <li>Center profile can be threaded for 3/8 bolt or threaded rod.</li> </ul>	<ul style="list-style-type: none"> <li>Attach end cap for vertical hanging, among other uses.</li> </ul>	
<ul style="list-style-type: none"> <li>Anodized matte black</li> </ul>	<ul style="list-style-type: none"> <li>"Invisible" on stage.</li> </ul>	

COMPONENTS							
<p><b>2 X 4 BEAM 20 FT</b></p> <p>Item Number: FRAM0001   Price: 475.00</p>		<p><b>2-WAY CORNER</b></p> <p>Item Number: FRAM0002   Price: 128.00</p>		<p><b>SPLICE BLOCK</b></p> <p>Item Number: FRAM0003   Price: 39.00</p>		<p><b>1/2" STRUT NUT</b></p> <p>Item Number: STRU0038   Price: 1.50</p>	
<p><b>3-WAY CORNER BRACKET</b></p> <p>Item Number: FRAM0004   Price: 64.00</p>		<p><b>4-WAY CORNER BRACKET</b></p> <p>Item Number: FRAM0005   Price: 79.00</p>		<p><b>OFFSET TEE BRACKET</b></p> <p>Item Number: FRAM0006   Price: 59.00</p>		<p><b>IN-LINE TEE BRACKET</b></p> <p>Item Number: FRAM0007   Price: 59.00</p>	

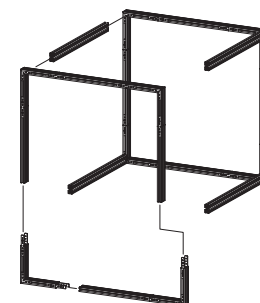

Product: Example of typical Cube Frame Construction using SpanFrame beam and bracket components.

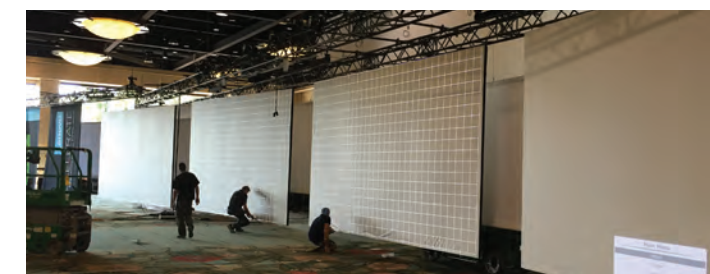

Product: Rose Brand Framing System, 20' x 15' Front White-160 Premium Projection Screen; Dolphin Resort in Orlando, FL; Pro Vision Productions Inc.

- Fabrics
- Black Masking
- Custom Stage Curtains & Backdrops
- Custom Special Event Sewing
- Digital Printing
- LED Star Drops
- Pipe & Base
- Rentals
- Projection Materials
- Flooring
- Curtain Track
- Stage Equipment, FXs & Mirrors
- DMX Winches
- Scenery Props
- Shop & Production Supplies
- Tape
- Film & Video Supplies
- Index



# Glassless Mirrors

Great for Stage & Display Effects



ASK ABOUT CUSTOM ROAD BOXES FOR MIRROR STORAGE

Product: Glassless Mirrors: Custom Single Panel Oscar de la Renta: The Rosewood at Youngs Bay Hotel. Courtesy of Fine Arts Museums of San Francisco



Bi-Fold



Single Panel



Tri-Fold



Single Panel



Single Panel

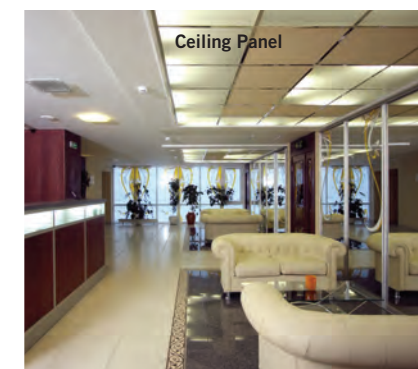

Ceiling Panel

## GLASSLESS MIRROR

Lighter and brighter than plate glass, glassless mirrors are made from a highly reflective metalized polyester film vacuum-stretched around a frame. The reflected image is brighter than a glass or plastic mirror and the surface won't shatter or break.

Glassless mirrors are lightweight and take minutes to install. They are easy to clean, requiring only a mild glass cleaner and a soft cloth. While it is not recommended that they be used outdoors, they normally will not fog in high humidity areas such as bathrooms.

Single Panels	Price
4' x 6' Wall-mount	368.00
4' x 6' Stationary	404.00
4' x 6' Rolling Stand	468.00
4' x 8' Wall-mount	399.00
4' x 8' Stationary	467.00
4' x 8' Rolling Stand	499.00
<b>Bi-Fold</b>	
24" x 72" Panels	567.00
<b>Tri-Fold</b>	
48" x 72" Middle Panel	
24" x 72" Side Panels	940.00
<b>Ceiling Panel</b>	
2' x 4'	63.00

Call for custom sizes and shapes.

### Glassless Mirrors are Ideal for:

- Dance Studios
- Dressing Rooms
- Stage Productions
- Merchandise Displays
- Casinos
- Night Clubs
- Lobbies
- Home and Commercial Gyms
- Educational Facilities
- Military Bases
- Physical Therapy Facilities

*Glassless Scrim Mirrors; AKA 2 way mirrors.* When front lit they reflect like regular mirrors. When light is increased behind them, they become transparent. Great for stage and display effects and ideal for masking ceiling security cameras. Available by special order \$27.00/sq.ft.



# Scenery Props

Vacuform Scenic Panels ..... 310  
 Molding Cloth ..... 312  
 Stage Props ..... 314



Product: Product: Molding Cloth; At *The Cross: Love Ran Red*; Presque Isle Wesleyan Church; Designer: Jeremy Hale; Photo: Barbara Halvorson

Fabrics
Black Masking
Custom Stage Curtains & Backdrops
Custom Special Event Sewing
Digital Printing
LED Star Drops
Pipe & Base
Rentals
Projection Materials
Flooring
Curtain Track
Stage Equipment, FXs & Mirrors
DMX Winches
<b>Scenery Props</b>
Shop & Production Supplies
Tape
Film & Video Supplies
Index



# Vacuform Scenic Panels



Great instant scenery — just add paint.  
Our .030 gauge panels are more durable and can still roll to ship UPS.\*

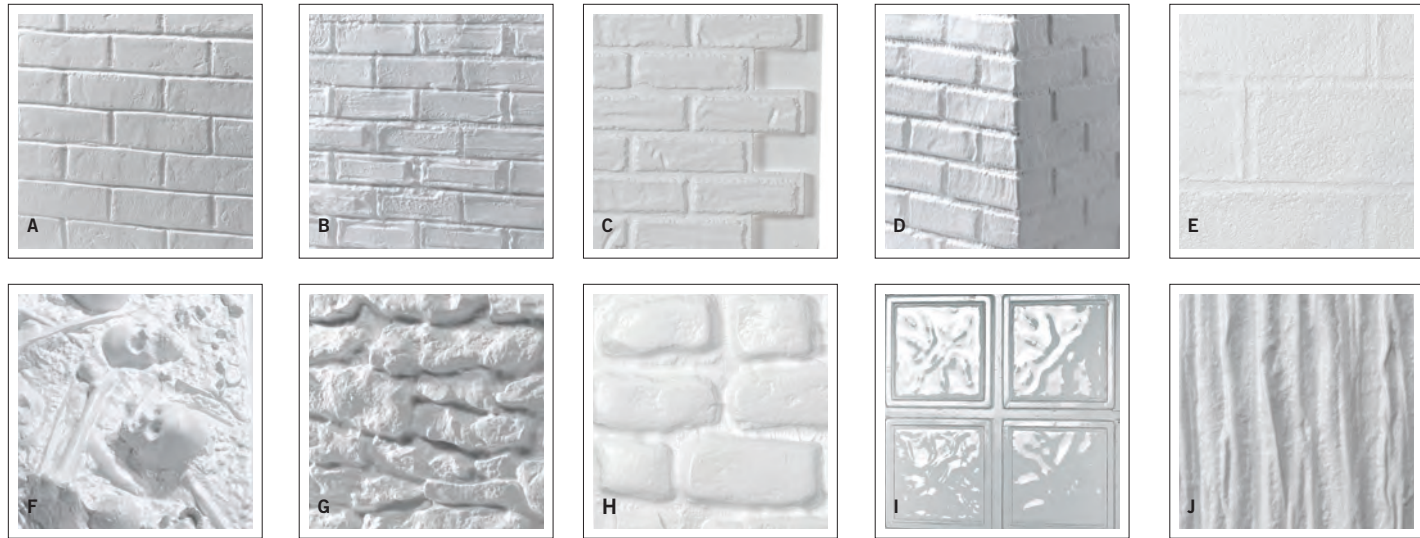

VACUFORM*				
ITEM	PANEL SIZE	PRODUCT SPECIFICATIONS		PRICE
<b>A</b>	<b>NEW BRICK</b>	4' H x 12'W	Gauge: .030. Panel runs horizontal. Bricks are sharp and modern looking.	141.50
<b>B</b>	<b>ROUGH BRICK</b>	3'11" x 11'9" x ¾ Deep	Gauge: .030. Brick size: 7½ x 2¼. Panel runs vertical. Modern look.	141.50
<b>C</b>	<b>OLD BRICK</b>	3'10½" x 11'11" x ½" Deep	Gauge: .030. Brick size: 7½" x 2½". Panel runs horizontal. Heavily textured, turn of the century brick facade.	141.50
<b>D</b>	<b>OLD BRICK CORNER</b>	10' H, each side is 1'7" W	Gauge: .030. Works with Old Brick panels.	141.50
<b>E</b>	<b>CINDER BLOCK</b>	4' x 11'	Gauge: .030. Brick size: 16" x 7". Panel runs horizontal. Prison cell walls, high school halls, gyms, etc.	141.50
<b>F</b>	<b>SKULLS</b>	4' H x 8' W 4'H x 12'W	Gauge: .030. Use horizontally or vertically. Features skulls and various bones. Great for Halloween.	131.00 143.00
<b>G</b>	<b>STACKED STONE WALL</b>	3'4" x 11'11"	Gauge: .030. Panel runs horizontal. Heavily textured to simulate a stone exterior.	141.50
<b>H</b>	<b>BELOVED COBBLESTONE</b>	3'11½" x 11'11" x 1"	Gauge: .030. Panel runs horizontal. Turn of the century look.	141.50
<b>I</b>	<b>GLASS BLOCK</b>	4' x 11'11"	Gauge: .030. Block 7¼" x 7¼". Available Translucent or Clear Glass Block Panel. Panels can be used vertical or horizontal.	165.00
<b>J</b>	<b>TREE BARK</b>	2 pieces 4' x 6' x ¾" sold as set.	Gauge: .030. Panel runs vertical. Can be wrapped around to simulate tree trunks.	141.50
	<b>*FITTED BOX</b>		Required for shipping items listed above. Holds 1 - 4 rolled sheets and ships via UPS/FedEx.	35.00

Vacuform available pre-primed with Rosco's Off-Broadway Deep Red, Payne's Grey or Burnt Sienna. Call for prices.

# Vacuform Scenic Panels



Hard to believe it's scenery.

Product: Vacuform — Old Brick  
*Un lío en dólares*  
 Estudio Cinematográfico Quitasueño, Haina, Dom Rep  
 Film Director: Francis Disla  
 Façade Designers: Angel Muniz, Sorangel Fersobe  
 Film Designer: Ruben Cordero  
 Scenic Painter: Miguel Hernandez  
 Top Photo: Jenniffer Calcaño  
 Two Photos To Right: Sorangel Fersobe, Miguel Hernandez



- Fabrics
- Black Masking
- Custom Stage Curtains & Backdrops
- Custom Special Event Sewing
- Digital Printing
- LED Star Drops
- Pipe & Base
- Rentals
- Projection Materials
- Flooring
- Curtain Track
- Stage Equipment, FXs & Mirrors
- DMX Winches
- Scenery Props
- Shop & Production Supplies
- Tape
- Film & Video Supplies
- Index



# Molding Cloth



# Molding Cloth



Natural Canvas



Printed Canvas/Earth

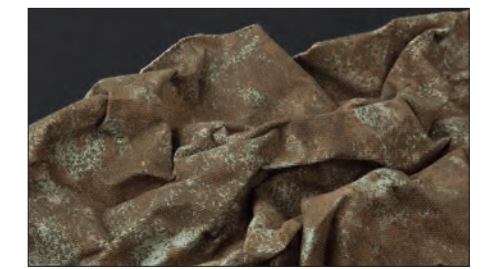

Printed Canvas/Forest

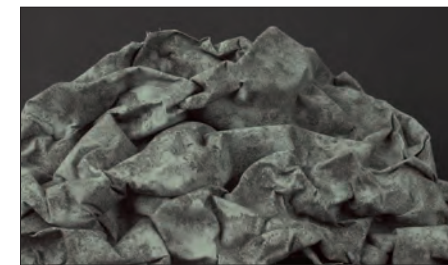

Printed Canvas/Stone



Printed Canvas/Bark

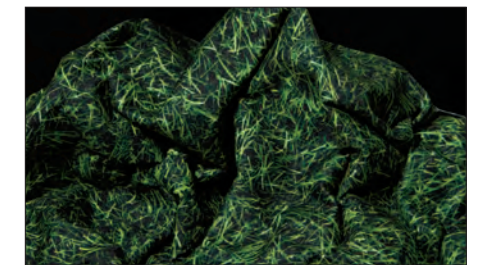

Printed Canvas/Grass



Printed Canvas/Volcano



Metallic/Gold



Metallic/Ice



Metallic/Melting Mirror



Metallic/Silver



Snow (Side View)



Photo of Red Velvet Ribbon in use

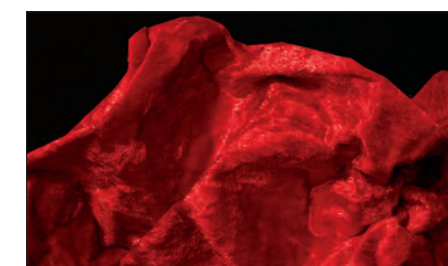

Red Velvet Ribbon

## MOLDING CLOTH

Innovative and re-usable. Fabric-coated aluminum core bends and molds easily and holds shape to make fabulous textured forms. The Natural Canvas Adhesive-Backed is an ideal substrate for the busy scene shop. The printed Earth, Stone, Forest, Volcano, Bark and Grass are ready to be molded into rocks, walls and trees. An incredible time saver in the shop or on-site. Sold by 10 yd. roll only.

Natural Canvas	Price Per Roll
48" FR Single-sided	470.00
48" FR Double-sided	525.00

Printed Canvas	Price Per Roll
48" FR Single-sided Earth	385.00
48" FR Single-sided Forest	385.00
48" FR Single-sided Stone	385.00
48" FR Single-sided Bark	385.00
48" FR Single-sided Grass	385.00
48" FR Single-sided Volcano	385.00

Metallic	Price Per Roll
48" FR Single-sided Gold	385.00
48" FR Single-sided Ice	375.00
48" FR Single-sided Melting Mirror	415.00
48" FR Single-sided Silver	385.00

Snow	Price Per Roll
47" FR Single-sided	385.00

Velvet Ribbon	Price Per Roll
48" FR Double-sided Red Velvet Ribbon	575.00

- Fabrics
- Black Masking
- Custom Stage Curtains & Backdrops
- Custom Special Event Sewing
- Digital Printing
- LED Star Drops
- Pipe & Base
- Rentals
- Projection Materials
- Flooring
- Curtain Track
- Stage Equipment, FXs & Mirrors
- DMX Winches
- Scenery Props
- Shop & Production Supplies
- Tape
- Film & Video Supplies
- Index





Products: Snow Blanket, Iridescent Confetti; *Bethlehem Blues*; Stage at Northside Christian Church, New Albany, IN; Producer/Director/Designer/Photo: Northside Connect Team



**IRIDESCENT CONFETTI**

Create a winter wonderland with this brilliant iridescent snow falling from our SnowStar machine. See page 296. Sparkles when sprinkled on our Snow Blanket.

	Price
FR 10 lb. box	55.00

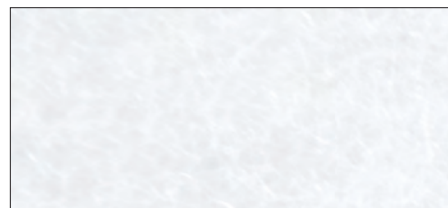

**SNOW BLANKET**

Flame Retardant 100% Dacron. Instantly transforms a space into a snowy landscape. Light weight and easy to use. Sprinkle with Iridescent Confetti for added sparkle. 1/2" thick.

	Price
FR 27 yard x 54" W	148.50



**FR PAPER CONFETTI**

A mixed assortment of loose, colorful, paper confetti in various sizes from 3/16" to 7/16". Mixed 25 lb. box includes yellow, orange, pink, red, blue, green, light yellow, teal, and dark green.

	Price
FR Paper Confetti - 25 lb. Box	265.00



**ICICLES**

Seasonal and festive, these icicles are highly realistic. Available either frosted or clear.

	Price
15"H x 48"W	14.25
36"H x 18"W	14.25



**FR SNOW**

Loose, white snowflakes. Also available in plastic flakes. Use with SnowStar machine, page 296.

	Price
FR Plastic Snow - 25 lb. Box	150.00
FR Paper Snow - 25 lb. Box	330.00



**ROSCO SILVER SHRINK MIRROR**

	Price
54" x 30" Roll	152.25

For Glassless Mirror Panels see page 307.



We can sew pieces of Camo Netting into larger custom backdrops. Call a Rose Brand sales rep for pricing.

**NFR CAMO NETTING**

	Size	Price
NFR Night, Snow, Urban, Desert	9'10" x 7'10"	50.00
NFR Woodland (small)	9'10" x 9'10"	77.00
NFR Woodland (large)	19'8" x 9'10"	142.00

**Front Side**



Snow White

**Reverse Side**



Woodland



Night

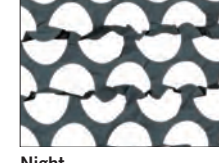

**Front Side**



Desert

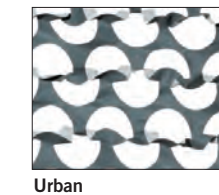

Urban

**Reverse Side**

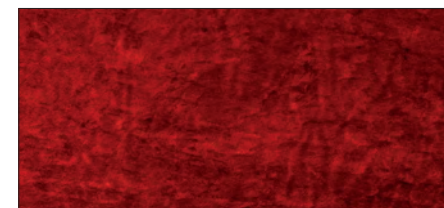
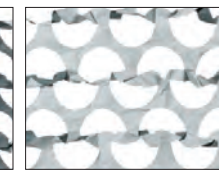

**DOUBLE-SIDED RED VELVET RIBBON MOLDING CLOTH**

Giant scale, 48" wide moldable Red Velvet. Build oversize ribbons and bows for holiday displays, floats, and decorations without the need for additional framing.

	Size	Price
48" FR Double-sided Red Velvet Ribbon	32 ft (10 m) rolls	575.00



**BRICK PATTERN SEAMLESS PAPER**

Realistic brick appearance. Ideal for theatrical and studio backdrops.

Available in **A** dark brown or **B** terracotta.

	Price
82" x 36' Roll	55.80



**LE FLAME**

Amazingly realistic flame effect using light, air flow and fabric. Non-dimmable circuit.

	Price
Le Flame (Unit without Bowl)	387.45
Le Flame/Stand/Bowl (Shown)	582.81
Le Flame/Hanging Bowl	415.80





Product: Inflatable Mirror Spheres; Supplier: Swag Decor; Designer: Tantawan Bloom; Photo: Ray Santana



Product: Inflatable Mirror Spheres; Supplier: Swag Decor; Designer: 50Fifty Creative Service; Event: Bascom Palmer Eye Institute Naples; Photo: 50Fifty Creative Service

### INFLATABLE MIRROR SPHERES NEW

A "wow" element for any event or party space. Highly reflective, mirrored spheres create a dynamic overhead design and add excitement to the lighting and decor. Easily inflated on site for lowered transport costs and worries. Mirrored surfaces are fragile and must be handled gently.

	Silver	Blue, Gold, Red
1 M (39")	225.00	245.00
2 M (78")	425.00	495.00
2.5 M (98")	550.00	625.00
	<b>Price</b>	
120 V Air Pump for Mirrored Spheres		49.95



## Stage Props

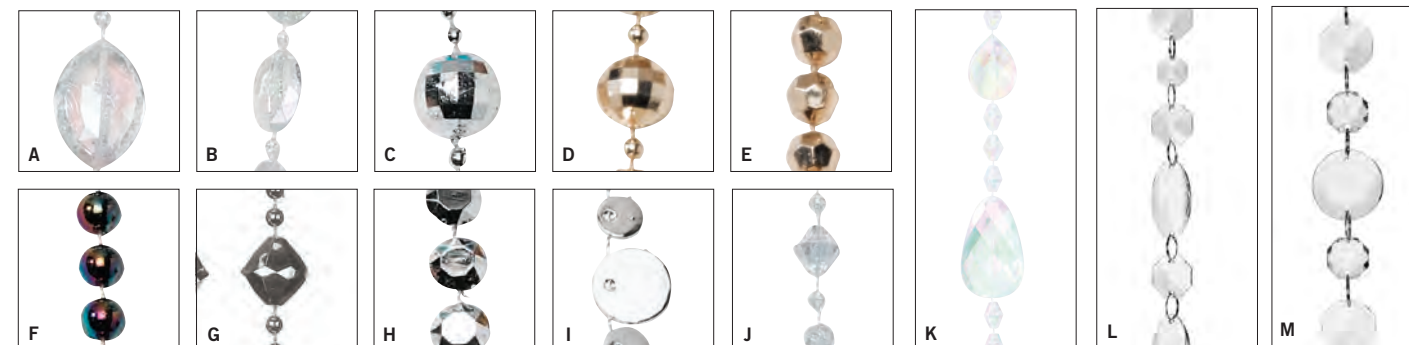

### BEADS BY THE ROLL

Make your own chandeliers, curtains or decorative accents.

	STYLE	COLOR	ROLL SIZE	PRICE
A	Lg. Faceted Oval	Iridescent	25 Yard Roll	96.00
		Gold, Silver	25 Yard Roll	87.50
B	Sm. Faceted Oval	Gold, Silver	22 Yard Roll	74.80
		Iridescent	22 Yard Roll	74.80
C	Disco Ball A	Silver	20 Yard Roll	60.00
		Iridescent	20 Yard Roll	60.00
D	Disco Ball B	Gold	25 Yard Roll	85.00
		Silver	20 Yard Roll	60.00
E	Mini Disco Ball	Gold	20 Yard Roll	60.00
F	10 mm Ball	Black Iridescent, Gold	25 Yard Roll	62.50
		Silver	20 Yard Roll	55.00
G	Tetra Diamond	Silver	25 Yard Roll	75.00
H	Diamond	Silver	30 Yard Roll	60.00
		Iridescent	30 Yard Roll	60.00
I	Disc	Silver	30 Yard Roll	60.00
J	Diamond Sphere	Iridescent	30 Yard Roll	60.00
K	Pear Beads	Gold, Silver	25 Yard Roll	90.00
K	Pear Beads	Iridescent	25 Yard Roll	100.00

### METAL LINK BEADS

Make your own chandeliers, curtains or decorative accents.

	STYLE	COLOR	PIECE SIZE	PRICE
L	Oval	Clear	30 Foot Piece	40.00
M	Circle	Clear	30 Foot Piece	40.00



### GLASS MIRROR BALLS

Perfect for parties, the traditional disco ball, made with glass mirrors, is available in 6 sizes. Made from pieces of mirror glass glued on a styrofoam ball. Rotator Motor sold separately.

	Diameter	Price
2"		4.50
4"		10.00
8"		35.00
12"		65.00
16"		120.00
20"		200.00
Rotator Motor for Disco Balls		17.60



# Shop & Production Supplies

Scenic Paints .....	320
Adhesive, Primers, Base Coats & Coatings.....	326
Adhesives .....	326
Primers & Base Coats.....	326
Coatings.....	327
Decorative Finishes .....	328
Studio Accessories .....	329
Faux Finishing .....	330
Theatrical Brushes .....	330
Sprayers .....	331
Flame Retardants .....	332
Topical Sealants .....	332
Flame Retardants .....	333
Certificate of Flame Resistance .....	334
Product Usage Recommendations .....	335
Tape .....	336
Production Supplies/Shop Supplies.....	340
Shop Papers.....	340
Load Out Supplies .....	341
Production Supplies/Sewing Supplies .....	342

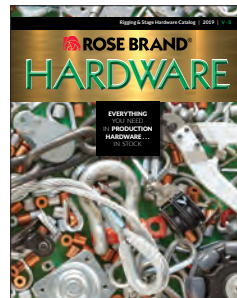

ORDER HARDWARE  
CATALOG ONLINE

**EVERYTHING YOU NEED IN  
PRODUCTION HARDWARE... IN STOCK**

Fabrics
Black Masking
Custom Stage Curtains & Backdrops
Custom Special Event Sewing
Digital Printing
LED Star Drops
Pipe & Base
Rentals
Projection Materials
Flooring
Curtain Track
Stage Equipment, FXs & Mirrors
DMX Winches
Scenery Props
Shop & Production Supplies
Tape
Film & Video Supplies
Index





**ROSCO SUPERSATURATED™ PAINT**

A highly-concentrated, vinyl acrylic system of brilliant theatrical colors. Supersaturated paints maintain their binder strength and vibrancy even when diluted with multiple parts of water. Use as a tint, opaque medium, or as an alternative to dyes.

Water-to-paint dilution ratio:  
1:1    3:1    10:1

For Complete Color Chart see RoseBrand.com



5988 Lemon Yellow



5968 Green Shade Blue



5982 Yellow Ochre



5981 Chrome Yellow



5991 Navy Blue



5993 Leather Lake



5984 Moly Orange



5989 Turquoise Blue



5983 Raw Sienna



5965 Red



5979 Purple



5987 Burnt Sienna



5977 Spectrum Red



5997 Hunter Green

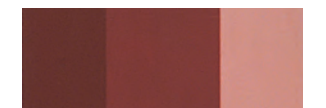

5980 Iron Red



5975 Magenta



5972 Emerald Green

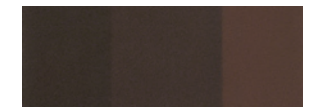

5985 Burnt Umber



5996 Cerulean Blue



5994 Grass Green

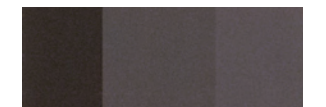

5998 Van Dyke Brown



5969 Ultramarine Blue



5973 Pthalo Green

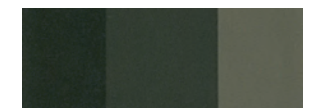

5986 Raw Umber



5990 Prussian Blue



5971 Chrome Green



6003 Velour Black

		Price	Qt.
5965	Red	43.85	
5968	Green Shade Blue	43.85	
5969	Ultramarine Blue	43.85	
5971	Chrome Green	43.85	
5972	Emerald Green	43.85	
5973	Pthalo Green	43.85	
5974	Imperial Green (not shown)	43.85	
5975	Magenta	43.85	
5976	Brilliant Red (not shown)	48.60	
5977	Spectrum Red	43.85	
5979	Purple	43.85	
5980	Iron Red	29.95	
5981	Chrome Yellow	43.85	
5982	Yellow Ochre	29.95	
5983	Raw Sienna	29.95	
5984	Moly Orange	43.85	
5985	Burnt Umber	29.95	
5986	Raw Umber	29.95	
5987	Burnt Sienna	29.95	
5988	Lemon Yellow	43.85	
5989	Turquoise Blue	43.85	
5990	Prussian Blue	40.95	
5991	Navy Blue	40.95	
5992	Payne's Grey (not shown)	43.85	
5993	Leather Lake	29.95	
5994	Grass Green	40.95	
5996	Cerulean Blue	40.95	
5997	Hunter Green	40.95	
5998	Van Dyke Brown	29.95	



**ROSCO SUPERSATURATED™ PAINT TEST KIT**

		Price
5935	Test Kit: 28-1 oz. samples. Neutral base not included.	85.25

**ROSCO SUPERSATURATED CONCENTRATED BASES™**

	Qt.	Gal.	Price
6001	Neutral	NA	49.10 NA
6002	White	NA	55.65 256.50
6003	Velour Black	24.70	70.10 306.10

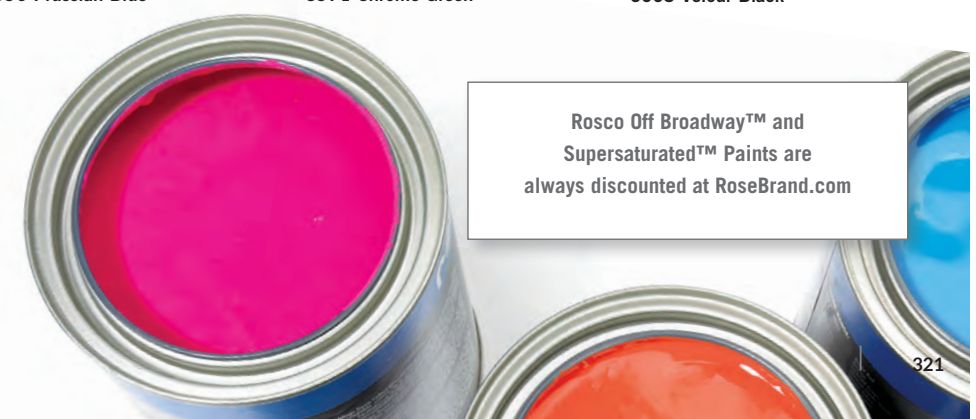

Rosco Off Broadway™ and Supersaturated™ Paints are always discounted at RoseBrand.com

- Fabrics
- Black Masking
- Custom Stage Curtains & Backdrops
- Custom Special Event Sewing
- Digital Printing
- LED Star Drops
- Pipe & Base
- Rentals
- Projection Materials
- Flooring
- Curtain Track
- Stage Equipment, FXs & Mirrors
- DMX Winches
- Scenery Props
- Shop & Production Supplies
- Tape
- Film & Video Supplies
- Index





NOTE: DO NOT USE FLAMEX PRODUCTS WITH METALLIC PAINTS.



**ROSCO OFF BROADWAY™ PAINT**

Quality scenic paints at an affordable price. Use these intense vinyl acrylic colors right out of the bucket, or dilute them. They adhere to a variety of surfaces and dry to a completely non-reflective, water-resistant finish.

		Qt.	Price Gal.
5353	Yellow Ochre	16.05	45.45
5354	Burnt Umber	16.05	45.45
5355	Raw Sienna	16.05	45.45
5356	Burnt Sienna	16.05	45.45
5357	Raw Umber	16.05	45.45
5358	Earth Umber	16.05	45.45
5359	Ultramarine Blue	22.85	65.10
5360	Fire Red	26.00	73.80
5361	Deep Red	25.75	73.00
5363	Orange	20.50	57.50
5364	Emerald Green	20.50	57.50
5365	Chrome Oxide Green	20.50	57.50
5366	Lemon Yellow	20.50	57.50
5367	Golden Yellow	20.50	57.50
5368	Purple	25.75	73.00
5369	Magenta	25.75	73.00
5371	Pthalo Green	20.50	57.50
5372	Sky Blue	20.50	57.50
5373	Pthalo Blue	20.50	57.50
5374	Imperial Green	27.30	77.45
5375	Navy	25.75	73.00
5376	Brilliant Red	27.30	77.45
5380	Van Dyke Brown	20.50	57.50
5382	Payne's Grey	27.30	77.45

		Pt.	Qt.	Price Gal.
5350	White	14.45	40.70	186.40
5351	White-White	17.10	49.10	218.95
5352	Black	16.05	45.45	202.65

		Pt.	Qt.	Price Gal.
5383	Bright Gold	26.25	40.95	116.85
5384	Gold	26.25	40.95	116.85
5385	Silver	26.25	40.95	116.85
5386	Copper	26.25	40.95	116.85
5387	Antique Gold	26.25	40.95	116.85

		Price
5300	Test Kit: 26-1 oz. samples plus Clear, Flat & Gloss.	85.25



**ROSCO FLUORESCENT PAINT**

Vivid under normal lighting conditions, fluorescent colors glow brightly when lit with an ultraviolet or black light.

	Pt.	Qt.	Price Gal.
5779	White	29.95	43.85 132.85
5780	Red	29.95	43.85 132.85
5781	Orange	29.95	43.85 132.85
5782	Yellow	29.95	43.85 132.85
5783	Green	29.95	43.85 132.85
5784	Blue	29.95	43.85 132.85
5785	Invis. Blue	31.25	47.00 163.05
5786	Pink	29.95	43.85 132.85
5787	Gold	31.25	47.25 139.65



**ROSCO FLUORESCENT PAINT TEST KIT**

	Price
6000	Test Kit: 9-1 oz. samples 58.20

**ROSCO VIVIDFX™ PAINT**

This ultra-violet special effects paint uses the highest quality fluorescent pigments available to give the artist an unparalleled combination of color choice, hiding power, fluorescence and versatility with one-coat coverage. The brilliant pigments are fluorescent under normal light, and stunningly vivid under UV or black light, intermixing cleanly to provide a wide array of intermediate fluorescent hues.

	Pt.	Qt.	Price Gal.
6250	Bright White	40.95	73.25 215.55
6251	Lem. Yellow	45.45	81.40 231.55
6252	Org. Sunset	40.95	73.25 215.55
6253	Orange	40.95	73.25 215.55
6254	Scarlet Red	40.95	73.25 215.55
6255	Hot Pink	40.95	73.25 215.55
6256	Magenta	40.95	73.25 215.55
6257	Violet	40.95	73.25 215.55
6258	Deep Blue	40.95	73.25 215.55
6259	Brilliant Blue	40.95	73.25 215.55
6260	Aquamarine	40.95	73.25 215.55
6261	Electric Grn.	40.95	73.25 215.55
6262	Deep Green	40.95	73.25 215.55



**ROSCO VIVIDFX™ PAINT TEST KIT**

	Price
6200	Test Kit: 13-1 oz. samples 72.10



**ROSCO IDDINGS DEEP COLORS™ PAINT TEST KIT**

	Price
5570	Test Kit: 25-1 oz. samples 87.05



**ROSCO IDDINGS DEEP COLORS™ PAINT**

Rich, concentrated scenic colors, made with a soy protein casein binder. Preferred by artists for over thirty years, Iddings renders brilliant results. Recommended for fabrics and porous surfaces. The addition of Clear Acrylics (diluted at a 1:1 ratio - See page 327) will enhance the paint's flexibility, permanence and resistance to water.

	Qt.	Gal.	Price 5 Gal.
5553	Yellow Ochre	23.40	65.10
5554	Burnt Umber	23.40	65.10
5555	Raw Sienna	23.40	65.10
5556	Burnt Sienna	23.40	65.10
5557	Raw Umber	23.40	65.10
5558	Van Dyke Brown	23.40	65.10
5559	Ultramarine Blue	29.95	81.40
5560	Red	29.95	81.40
5561	Dark Red	32.85	105.80
5562	Bright Red	32.85	105.80
5563	Orange	32.85	105.80
5564	Emerald Green	29.95	81.40
5565	Chr. Oxide Green	29.95	81.40
5566	Lemon Yellow	32.85	105.80
5567	Golden Yellow	32.85	105.80
5568	Purple	32.85	105.80
5569	Magenta	32.85	105.80
5570	Turquoise Blue	29.95	81.40
5571	Dark Green	29.95	81.40
5572	Cerulean Blue	29.95	81.40
5573	Navy Blue	29.95	81.40

	Qt.	Gal.	Price 5 Gal.
5551	White	19.95	57.50 256.20
5552	Black	23.40	65.10 291.65





## Scenic Paints



### WILDFIRE ULTRAVIOLET SENSITIVE PAINTS

The standard of quality for visual effect professionals. Wildfire fluoresces brilliantly under blacklight. The invisible paint colors will appear white under ordinary lighting changing to bright glowing colors when blacklight is applied. The visible colors show actual color in visible light and glowing in blacklight.

Wildfire Invisible Clear Color Polyurethane Top Coats are clear under ordinary light, but reveal their color under black light. Used as a top layer, the clear coat will allow the underlying layer to be visible in ordinary light. But under black light, the top paint coat reveals its color.

Invisible	Qt.	Price Gal.
Invisible Blue/Ice Blue	51.55	145.39
Invisible Glow Green	83.23	276.77
Invisible Green	256.83	733.07
Invisible Orange	239.82	991.95
Invisible Red	359.48	1,261.60
Invisible Yellow	94.96	316.65
Visible	Qt.	Price Gal.
Bright Green	51.55	145.39
Bright Orange	51.55	145.39
Bright Red	51.55	145.39
Brilliant Yellow	51.55	145.39
Deep Blue	51.55	145.39
Deep Violet	51.55	145.39
Deep Yellow	51.55	145.39
Hot Pink	51.55	145.39
Magenta	51.55	145.39
Optical White	69.15	198.17

Invisible Clear Colors	Qt.	Price Gal.
Invisible Clear Color Black	111.38	319.00
Invisible Clear Color Blue	111.38	319.00
Invisible Clear Color Yellow	140.70	402.28
Invisible Clear Color Green	209.92	600.52
Invisible Clear Color Red	221.64	633.36



### ARTIST'S CHOICE™

Artist's Choice™ water-based colors are made with a revolutionary resin and are designed to be extended with water or other paint products. These highly saturated hues are clean, crisp and vibrant. They blend smoothly and provide superior hiding, absorption and sag resistance.

	Qt.	Price Gal.
7701 Daylight Blue	22.07	65.12
7702 Midnight Blue	24.08	67.41
7703 Pthalo Blue	22.07	65.71
7704 Ultramarine Blue	26.76	74.79
7705 Royal Purple	26.63	84.13
7706 Magenta	26.63	84.13
7707 Rich Red	26.63	84.13
7708 Bright Red	25.16	78.60
7709 Orange	25.16	78.60
7710 Golden Yellow	24.60	76.61
7711 Primary Yellow	24.60	76.61
7712 Primary Green	22.61	65.45
7713 Pthalo Green	25.95	76.10
7714 Oxide Green	23.95	67.55
7715 Yellow Ochre	18.45	50.66
7716 Raw Sienna	18.45	50.66
7717 Burnt Sienna	18.45	50.66
7718 Burnt Umber	18.45	50.66
7719 Raw Umber	18.45	50.66
7728 Van Dyke Brown	18.45	50.66
7730 Navy Blue	23.95	65.71
7731 Dark Red	26.63	84.13
7732 Emerald Green	23.95	67.55

	Qt.	Gal.	Price 5 Gal.
7720 Mask Black	18.45	48.60	210.39
7721 N. Tone Grey	18.12	45.85	200.39
7722 White	17.10	45.19	197.23
7723 Dbl. White	18.72	50.31	226.42
7724 Met. Gold	33.06	98.00	
7725 Met. Silver	33.06	98.00	
7727 Met Copper	33.06	98.00	

7726 Starter Test Kit: 79.95  
30-piece kit contains 1 oz. samples of Artist's Choice™, Plastic Varnish™ Gloss & Flat, Sculpt or Coat® and Primer.

7701 Daylight Blue	7715 Yellow Ochre
7702 Midnight Blue	7716 Raw Sienna
7703 Pthalo Blue	7717 Burnt Sienna
7704 Ultramarine	7718 Burnt Umber
7705 Royal Purple	7719 Raw Umber
7706 Magenta	7721 Neutral Tone Grey
7707 Rich Red	7724 Metallic Gold
7708 Bright Red	7725 Metallic Silver
7709 Orange	7727 Metallic Copper
7710 Golden Yellow	7728 Van Dyke Brown
7711 Primary Yellow	7730 Navy Blue
7712 Primary Green	7731 Dark Red
7713 Pthalo Green	7732 Emerald Green
7714 Oxide Green	

**NOTE:**  
DO NOT USE FLAMEX PRODUCTS WITH METALLIC PAINTS.

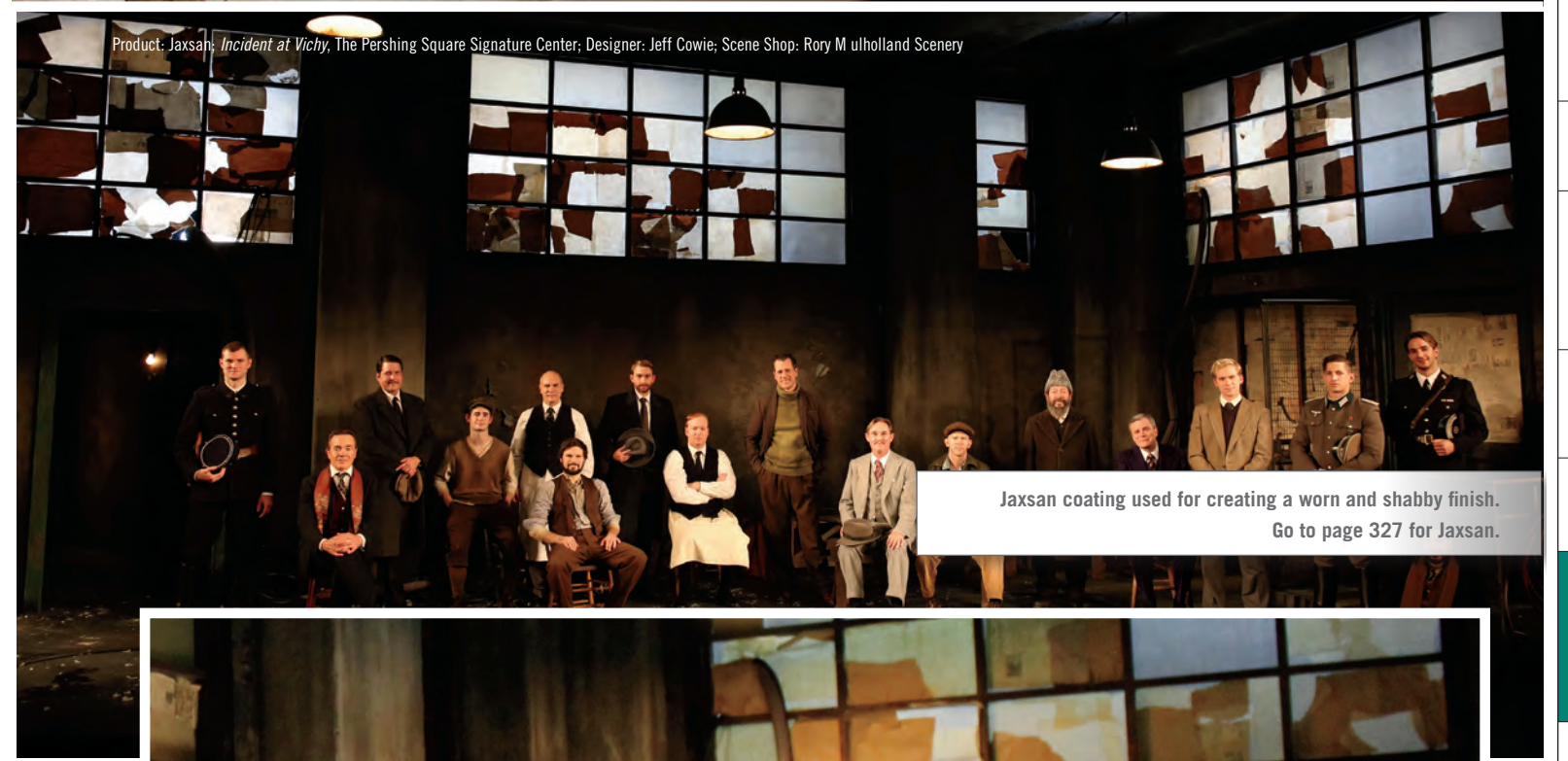

- Fabrics
- Black Masking
- Custom Stage Curtains & Backdrops
- Custom Special Event Sewing
- Digital Printing
- LED Star Drops
- Pipe & Base
- Rentals
- Projection Materials
- Flooring
- Curtain Track
- Stage Equipment, FXs & Mirrors
- DMX Winches
- Scenery Props
- Shop & Production Supplies
- Tape
- Film & Video Supplies
- Index



## Adhesives



### ROBO GLUE

A fast setting, non-toxic, water-based, general purpose adhesive that dries clear and remains flexible. Use for bonding fabrics, paper, non-porous surfaces and wood to metals. Can be used for porous substrate to difficult-to-bond synthetic materials. Robo Glue is great for bonding scenery netting to cut drops.

	Price		
	Pint	Gal.	55 Gal. Drum
	6.00	33.50	1,455.40



### ROSE BRAND GLUE

Our general purpose, water-based white glue sets quickly and dries clear. This non-flexible glue bonds most porous and non-porous items. The perfect shop glue.

	Price		
	Gal.	5 Gal.	55 Gal. Drum*
	15.60	69.60	700.00
			*475 lbs.



### ROSCO FLEXBOND™

A water-based scenic glue that dries to a clear, pliable coating. Used on paper, fabric, wood and foam surfaces it can be thinned, tinted or added to other coatings.

	Price	
	Gal.	5 Gal.
	49.55	221.30



### FLEX GLUE

Water-based adhesive. Use where a "white" glue with flexibility is needed. Dries clear in approx. 1 hour. Great clear coating for fabrics. Adding Mixol Tints or dry pigments creates color coatings.

	Price	
	Gal.	5 Gal.
		59.60

## Primers & Base Coats



### ROSCO TOUGH PRIME™

A unique water-based primer, Tough Prime bonds to just about any surface, including PVC pipe, aluminum, steel, wood, foams and plastics. Tough Prime is tintable and blocks water stains and dyes. Can be used for interior and exterior applications. Black is perfect for stage flooring or metal structures.

	Price	
	Gal.	5 Gal.
White, Black	60.15	271.45



### TOUGH'N WHITE PRIMER™ & METAL PRIMER™

Tintable primer-sealer with outstanding adhesion. Can be used for interior or exterior applications, under water-based or oil-based top coats. The metal primer is rust-inhibitive and has super adhesion on hard-to-grip and metal surfaces.

	Price	
	Qt.	Gal.
Tough'N White Primer™	17.79	49.36
Metal Primer™	24.24	54.72



### ARGO® STARCH

Recipe for Sizing Drops: Slowly and continuously stir 1 lb. Box of Argo Starch into ½ gallon cold water. Boil 3½ gallons water in large pot. When boiling, slowly stir in cold starch mixture. Reboil and then remove pot from stove. Use the starch as follows: 1. Strain it and use it warm; this will soak through the muslin. Good for opaque drops. 2. Cool it, strain it and use it; this will sit on top of the muslin. Good for translucent drops. 4 gallons covers approx. 400 sq. ft.

	Price	
	Qt.	Gal.
1 lb. Box		3.75
Case - 24 1 lb. Boxes		72.00



### SCULPT OR COAT™

Versatile, non-toxic, water-based plastic cream for tough, flexible coating, texturing and sculpting. Use as an adhesive, a sculpting medium, a filler or a texture. Air dries to a clear finish.

	Price		
	Qt.	Gal.	5 Gal.
	31.03	60.89	272.35



### PLASTIC VARNISH™

An exceptional, non-toxic plastic liquid for clear coating of scenery, props, furniture, floors, walls and crafts. Water-extendable. Dries to a clear, durable, hard finish.

	Price		
	Qt.	Gal.	5 Gal.
Flat or Gloss	21.48	44.66	199.36



### JAXSAN 600

Flame Retardant. Flexible acrylic latex coating for wood, cloth, plastic, masonry and various foams. Water-thinnable. Non-toxic, water-proof, weather resistant. Tintable. Stocked in White and Black. Available by special order in Aluminum, Light Grey, and Tan.

	Price	
	2 Gal.	5 Gal.
White	75.00	180.00
Black	NA	180.00



### ROSCO PREMIERE CLEAR

Water-borne urethane coating for sealing & protecting painted finishes, floors and high-traffic surfaces. Virtually odorless. Water-extendable. Cures to hard, durable, abrasive finish. Excellent for faux finishes & glazing applications.

	Price	
	Qt.	Gal.
Flat, Satin or Gloss	24.70	72.45



### ROSCO FOAMCOAT™

Inherently Flame Retardant. Provides a hard, durable finish for styrofoam, polystyrene and other surfaces. Ideal substitute for joint compound or plaster. Non-toxic. Water-based.

	Price	
	Gal.	3.5 Gal.
IFR	68.75	228.75

### ROSCO FLEXCOAT™

Inherently Flame Retardant. Non-toxic water based coating for polyurethane, foam, styrofoam and ethafoam. 100% acrylic. Provides excellent adhesion. Will not become brittle with exterior exposure. Weatherproof.

	Price	
	Gal.	5 Gal.
IFR	68.75	308.25



### ROSCO CLEAR ACRYLIC GLAZES™

Versatile acrylic mediums that can be used to protect other painted finishes, provide additional strength and adhesion to other scenic paints or to create transparent glazes or color washes. Can be used with Rosco Flamex PA FR Additive.

	Price	
	Gal.	5 Gal.
Flat or Gloss	50.95	228.15



### ROSCO CRYSTAL GEL

Non-toxic, water-based. Provides a clear plastic-like coating. Air dries to a flexible, translucent surface. Can be painted or carved when dry. Texture can be added.

	Price	
	Gal.	5 Gal.
	68.75	308.25



### STREET SHOE FLOOR FINISH

Commercial Wood Floor Finish with XL Catalyst is a water based system formulated especially for high traffic wood floors. It provides a clear finish that remains unmatched in performance and durability. Apply to bare or stained wood and painted floors. Coverage is 550 -700 ft²/gal. Dry time is 2-3 hrs between coats.

	Price	
	1 Gal.	
Gloss or Super Matte		110.25



### MICROSPERSION 31®

An additive which imparts scuff and abrasion-resistant qualities to water-based paint. Good for high traffic areas. Will not affect the color or texture of paints. One 12 oz. bottle treats one gallon of paint.

	Price	
	12 oz. Bottle	
		9.75



### AQUA RESIN

Inherently Flame Retardant. Easy-to-use, non-toxic, water-based resin. 2 components, Liquid L and Powder S3. Mix 2-3 parts "S3" to 1 part "L". This opaque material is mixable as a gel coat, a laminating resin for use with fiber reinforcement, or as a putty. Accelerator, thickener, and separative also available. Permanent in both interior and exterior applications. Cuts, shapes and sands easily. Compatible with virtually all tints, paints and finishes. Easy clean-up. Class "A" fire rating.

Laminating & Gel Coat	Price
Liquid L-2.2, 2.2 lbs. (Quart)	24.65
Liquid L-8.8, 8.8 lbs. (Gallon)	73.00
Liquid L-43, 43 lbs. (5 Gallon Pail)	296.05
Liquid L-55, 473 lbs. (Drum)	2,770.00
Powder S3-6.6, 6.6 lbs.	36.25
Powder S3-26, 26.4 lbs.	108.75
Powder S3-43, 43 lbs. (Pail)	138.00
Powder S3-55, 473 lbs. (Drum)	1,335.00
Accelerator X-8, (8 fl. oz.)	17.00
Thickener TH-6, (8 fl. oz.)	24.65
Separative SP-8, (8 fl. oz.)	15.00



## Decorative Finishes



### KOLCAUSTICO™ PLASTER

Water-based, waxless, synthetic Venetian plaster. Kolcaustico™ is used to achieve a variety of faux-finishing techniques. Applied in multiple coats, Kolcaustico™ remains translucent, creating surfaces with an unparalleled visual depth. Accepts universal tints including Mixol® Tints. Can be burnished to a mirror-like finish with an application blade. Kit contains 1 qt. of Kolcaustico™, 3 colors of Mica Powder, 1 50 ml. can of Liberon Black Bison Neutral Paste wax and 1 Surface Knife.

	Price
	1 Gal. 2 Gal. 5 Gal.
	92.00 164.00 390.00

### Price

Steel Surface Blades, Set of 4	40.00
Plastic Surface Blades, Set of 4	7.00

Call for Tech Sheet on Kolcaustico™.



### MIXOL® TINTS

Highly concentrated, versatile tint system, MIXOL® can be added (up to 10% by volume) to almost any type of paint, varnish or Kolcaustico™. Suitable for interior or exterior applications, MIXOL® is highly resistant to frost or heat damage.

	Price	200 ml.	500 ml.
(01) Black	30.70	68.50	
(02) Umber	30.70	68.50	
(03) Oxide Brown	30.70	68.50	
(04) Oxide Red	30.70	68.50	
(05) Oxide Yellow	30.70	68.50	
(06) Maize Yellow	44.50	102.00	
(07) Canary Yellow	44.50	102.00	
(08) Green	40.50	92.50	
(09) Blue	40.50	92.50	
(10) Red	40.50	92.50	
(11) Violet	44.50	102.00	
(12) Fir Green	40.50	92.50	
(13) Grass Green	40.50	92.50	
(14) Oxide Green	40.50	92.50	
(15) Olive Green	34.00	73.00	
(16) Lime Green	34.00	73.00	
(17) Mustard	34.00	73.00	
(18) Orange	44.50	102.00	
(19) Camel	34.00	73.00	
(20) Oxide Chestnut	34.00	73.00	
(21) Oxide Terra Brown	34.00	73.00	
(22) Oxide Tobacco	34.00	73.00	
(23) Oxide Dark Brown	34.00	73.00	
(24) Oxide Stone Grey	34.00	73.00	
(25) Oxide White	34.00	73.00	
(26) True Yellow	62.00	143.00	
(27) True Red	62.00	143.00	
(28) True Pink	62.00	143.00	
(29) Oxide Brilliant Black	40.50	N.A.	
(30) Oxide Brilliant Yellow	129.00	N.A.	
(31) Oxide Brilliant Green	129.00	N.A.	
(32) Oxide Brilliant Blue	129.00	N.A.	
(99) Ocean Blue	40.50	92.50	

200 ml. Mixol® Tints sold in sets: 1-12, 13-24, 1-24. Call for pricing or visit rosebrand.com.



### MICA POWDER

Non-tarnishing Mica Powders can be added to varnishes, shellacs and wax to be used as metallic coatings. Dry Mica powders can also be applied directly onto a sized surface (Flash Gilding). These powders are non-toxic and environmentally safe.

24 colors available in 100 g, 500 g, 1 kg and 5 kg jars. Call for color/price list.

	Price
24 Colors – ½ oz. Samples	75.00
Mica Color Chart – 24 Colors	30.00
Color Chart + Samples	120.00



7 most popular colors shown.



### MICA POWDER INTRODUCTORY KIT

The Mica Powder Kit contains easy to follow, step-by-step instructions, tools and materials to produce outstanding results. Kit contains 24 colors – ½ oz. samples, 4 oz. can of Gilding Size, Leaf Adhesive, Acrylic Clear Coat, 2 Natural Hair Brushes, Cheesecloth and Mixing Sticks.

Price
80.00

## Decorative Finishes



### METAL LEAF

Copper, Aluminum, Imitation Gold Color #2½. Also available in rolls of 50m or 75m sizes between ¼" and 6¼". Copper not available in 75m rolls. Call for roll pricing. Pack of 500 leaves (5½" x 5½") covers approx. 105 sq. ft.

	Price
Pack of 500 Leaves Silver, Gold	123.75
Pack of 500 Leaves Copper	150.00

Call for roll pricing or visit rosebrand.com.



### GILDING SIZE

Water-based leaf adhesive, designed for Imitation Gold, Aluminum, Copper Leaf and Mica Powder. Quick tack time: ready for gilding after 15-30 minutes.

	Price
	4 oz. Qt. Gal.
	10.25 20.50 60.00



### WUNDA SIZE

Water-based, synthetic size for gilding. Reaches tack in 15 min. Can thin with water up to 10%. Open time up to 36 hours.

	Price
	Qt. Gal.
	22.50 55.00

### Kit A



### Kit B



### GILDING KITS

**Kit A:** The Basic Gilding Kit includes the tools and materials to apply imitation leaf to a properly prepared surface. Kit contains 4 oz. Gilding Size, Natural Hair Brush, 600 Wet/Dry Sandpaper, Cotton and Mixing Sticks, and a Book of Leaf and step-by-step instructions.

**Kit B:** The Gilding Project Kit contains the required tools and materials to produce outstanding results. Kit contains 4 oz Gilding Primer, 4 oz. Leaf adhesive, 4 oz. Acrylic Clear Coat, Natural Hair Brush, 600 Wet/Dry Paper, Cotton Gloves, Cheesecloth and Mixing Sticks and a Book of Leaf.

	Price
Kit A	30.00
Kit B	44.25

Specify type of leaf when ordering kits A and B.

### PLASTIC GLITTER

Vibrant colors. .040 particle size. 1 lb Jar.

	Price
Colors	12.00
Fluorescent Colors	14.50
Stardust	34.00

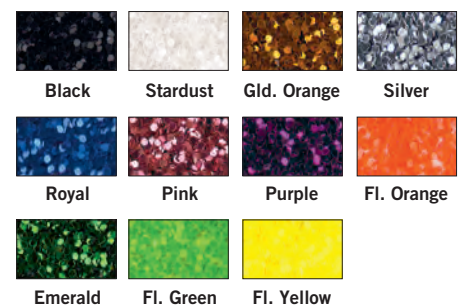

## Studio Accessories



### SEA SPONGE

First quality natural sponge. 6½" Diameter.

Price
8.00



### BOX-O-RAGS

T-shirt wipers.

	Price
50 lb. Box	105.00



### BAMBOO DRAWING STICKS

4' lengths. Dimensions vary slightly.

	Price
Sold in 5-piece lots.	
1" Large	16.00



### WILLOW CHARCOAL

	Price
Powdered Vine - 6 oz. Jar	10.50
Jumbo Vine Sticks - 10 pc., ½" Dia.	11.00
Vine Charcoal - 25 pc., ¼" Dia.	22.50



### POUNCE WHEEL

For perforating patterns.

	Price
	16.00



## Faux Finishing

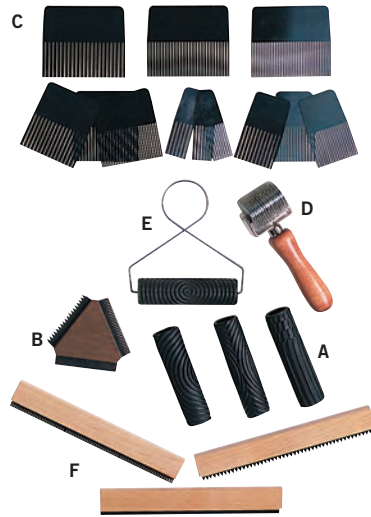

### WOOD GRAINERS

Simulate natural wood grain effects quickly and easily with these professional quality graining tools. Call for instructional tech sheet.

	Price
<b>A</b> Graining Rollers, set of 3	17.10
<b>B</b> Triangular Comb	10.80
<b>C</b> Steel Combs, set of 12	24.50
<b>D</b> Check Roller, oak effects	30.00
<b>E</b> Wire Handle Graining Roller	9.10
<b>F</b> 9", 3 pc. Graining Bar Set	21.00

See Page 336 for Pro-Scenic Blue Mask Painter's Tape.

## Theatrical Brushes



### PURDY XL BLUE JAY PAINT BRUSHES

Nylon/Polyester brushes with a round-edged ferrule and hand-chiseled bristles. Great for lining and general painting.

	Price
2"	22.50
3"	22.50



### PURDY SYNTAX

For use with all clear coatings. Long natural handle with a square edge stainless steel ferrule.

	Price
2½"	17.85



### PURDY DALE ELITE PAINT BRUSHES

Polyester, hand-chiseled bristles. Ferrule is square-edged. Recommended for both interior and exterior projects and made to be used with all paints. Great for lining and general painting.

	Price
1"	12.15
2"	16.75



### FOAM BRUSHES

Wood handles. 10 Piece set.

	Price
1"	5.00
2"	7.00
3"	8.60
4"	10.80



### CHIP BRUSHES

All purpose, natural bristle brushes with wood handles.

	Price Per Case
½" - 36 pieces	10.08
1" - 36 pieces	13.00
1½" - 36 pieces	15.00
2" - 24 pieces	11.70
3" - 12 pieces	14.00
4" - 12 pieces	25.00



### ROSCO FITCH BRUSHES

Professional quality scenic liners. Seamless, stainless steel ferrules and natural hog bristles.

	Price
¼"	7.25
½"	9.00
¾"	14.00
1"	19.00
1¼"	24.75
1½"	30.00
2"	37.00
3"	58.50
7 pc. Brush Set: ¼" - 2"	117.25
8 pc. Brush Set: ¼" - 3"	159.00



### PREVAL SPRAYER

Handheld sprayer. Use with paints, clear coatings, cleaners, solvents, gel coats and dyes. Reusable glass jar. Each replaceable power unit sprays up to 16 oz. of liquid. Ground shipping only.

	Price
Kit	6.65
Replacement Cartridge	5.25



### P-50 SPRAYER

Ergonomically designed hand-held sprayer with a capacity of 48 oz. Features an adjustable nozzle for different spray settings.

	Price
	62.00

## Sprayers



### GLORIA FLORETTA 89 SPRAYER

Sturdy Design with large base for standing stability. Adjustable brass nozzle has variable positions and rotates for the most spraying options.

	Price
	65.00



### HUDSON STAINLESS STEEL SPRAYER

Hudson 3.5 gallon sprayers are a standard in every scene shop, with hose, flat fan nozzle, pump and long extension for easy spraying. Available in both durable, corrosion resistant stainless steel, or the more economical galvanized steel. Cone Nozzle also available.

	Price
Stainless Steel	240.00
Galvanized	165.00
Cone Nozzle	8.00

See Page 340 for Bogus Paper.



**FIRE SAFETY IS SERIOUS BUSINESS**

Rose Brand offers years of experience, dedicated support and practical solutions for your scenic flame retardant needs. Our goal is to guide your choices of fabrics and FR chemicals so you and your audiences are safe.

Your local fire marshal or building inspector is the final authority to approve your use of these products. Fire safety laws tell them to be guided by established codes and laboratory testing. However, fire marshals are allowed to use their field observations and match tests to override certificates and lab test reports. You should treat and pre-test samples of all your substrates and have them approved by the fire marshal prior to installation. Rose Brand only warrants that we have accurately represented the manufacturers' claims about the fabrics and chemicals that we sell. Our staff will be glad to assist you by phone or e-mail with product selection, approval procedures, and documentation requirements.

The chart on page 317 is intended as a starting guide for product selection. Satisfactory fire resistance depends on proper identification of the substrate and proper application of the chemical according to manufacturer's directions.

The following charts show our most popular products only. For a complete, up-to-date list of chemical options, see RoseBrand.com. On our website you will find the NYC and California registration numbers for these and other chemicals and for our registered fabrics. Our website also has sample FR certificates for our fabrics.

**Topical Sealants**

Topical Sealants work by coating substrates, making an FR barrier between the substrate and the source of ignition, such as with back-painting scenery. Since the substrate itself may not be previously treated and remains untreated throughout, some fire marshals may not accept topical treatment for temporary decorative and scenic materials, although most do. Topical treatments alone are almost never acceptable by building code for permanent construction materials.

Paint additives will not change opacity or color of paints and sealants or change the coverage. They are ideal for non-porous substrates, untreated wood products, or previously painted scenery. Add to a clear acrylic glaze to create an FR sealant. Each yields a "Class A" or "I" rating to your coating.

See page 333 for FR scenic coatings and use the product usage chart on page 335 for other FR coating options.

PAINT ADDITIVES				
PRODUCT	SPECIFICATIONS			
TOPICAL SEALANTS	Application	Coverage	Quantity	Price
FR-1	Liquid additive for water-based paints. Not registered for use in NYC or the state of California.	Treats 1 Gallon	8 oz.	9.75
		Treats 12 Gallons	12 pack	111.15
		Treats 16 Gallons	1 gal.	139.00
ROSCO FLAMEX PA FDNY CAFM	Compatible with all water-based, acrylic paints including Clear Acrylic Glazes™. CAFM	Treats 1 Gallon	8 oz.	17.85
		Treats 12 Gallons	12 pack	189.30
		Treats 80 Gallons	5 gal.	1,160.20

NOTE: Do not use Flamex Paint Additive with metallic paints.

Liquid flame retardants are effective by penetrating into the raw, porous substrate to inhibit its ignition. They are water-based and non-durable (will wash out). All dry clear. The products for fabrics will make the fabrics passable for NFPA 701.

LIQUID FLAME RETARDANTS				
PRODUCT	SPECIFICATIONS			
ABSORBENTS FOR FIBERS	Application	Coverage	Quantity	Price
ROSCO FLAMEX NF FDNY CAFM	For use on most natural fibers. Apply by pad or spray.	500 sq.ft./gal.	1 gal. Container	48.75
			5 gal. Bucket	224.05
ROSCO FLAMEX DF FDNY CAFM	Pre-mixed for use on sheers, fine weave synthetics, rayon and silks. Apply by pad or spray.	600 sq.ft./gal.	1 gal. Container	72.40
			5 gal. Bucket	336.05
ROSCO FLAMEX SF FDNY CAFM	Pre-mixed for use on many synthetic fabrics or blends. Apply by pad or spray.	500 sq.ft./gal.	1 gal. Container	72.40
			5 gal. Bucket	336.05
ROSCO FLAMEX PC FDNY CAFM	Pre-mixed for use on paper, unwaxed cardboard and other similar materials. Apply by pad, roller, brush or spray.	400 sq.ft./gal.	1 gal. Container	72.40
			5 gal. Bucket	336.05
ROSCO FLAMEX WD CAFM	Pre-mixed for use on unsealed raw wood, straw, and other cellulose materials, but not on materials containing pitch, such as bark or Christmas trees. Apply by pad, roller, brush or spray. Effective treatment usually needs two coats.	300 sq.ft./gal.	1 gal. Container	72.40
			5 gal. Bucket	336.05
FF-4L FDNY CAFM	Pre-mixed, multi-purpose liquid for natural and synthetic fibers and blends. Gives Class B Rating to wood.	150-200 sq.ft./gal.	1 qt. Spray Bottle	23.00
			1 gal. w/Sprayer	49.00
			5 gal. Bucket	230.00
FF-6 FDNY CAFM	Pre-measured liquid concentrate for natural fibers. Ships in a convenient 5-gal bucket with 11.6 oz of concentrate—just fill with water, mix and apply. The most economical flame retardant you can buy. Ships from CA.	150-200 sq.ft./gal.	5 gal. Bucket	75.00
MG-702 NFPA 701 for cottons Calif. Title 19 for cottons & synthetics	Pre-mixed for multiple uses.	300 sq.ft./gal.	1 qt. Spray Bottle	18.00
			1 gal. w/Sprayer	38.00
			5 gal. Bucket 55 gal. Drum	160.00 1,595.00
MG-790	Pre-mixed liquid for raw wood and wood products. Dries clear. Exterior use.	100-150 sq.ft./gal.	1 gal. Container	38.00
			5 gal. Bucket	160.00



FDNY APPROVED & REGISTERED BY CITY OF NEW YORK FIRE DEPT. CAFM APPROVED & REGISTERED BY THE CALIFORNIA STATE FIRE MARSHALL. ALL ROSE BRAND FLAME RESISTANT FABRICS PASS NFPA 701 TESTING. SEE ROSEBRAND.COM FOR ADDITIONAL FR STANDARDS AND REGISTRATION NUMBERS.

Fabrics  
Black Masking  
Custom Stage Curtains & Backdrops  
Custom Special Event Sewing  
Digital Printing  
LED Star Drops  
Pipe & Base  
Rentals  
Projection Materials  
Flooring  
Curtain Track  
Stage Equipment, FXs & Mirrors  
DMX Winches  
Scenery Props  
Shop & Production Supplies  
Tape  
Film & Video Supplies  
Index



INSTANT FLAME RETARDANTS - just add water!				
Pre-measured packets quickly dissolve in water for spraying, painting, rolling or immersion treatments. Concentrations are pre-determined - no measuring.				
PRODUCT	SPECIFICATIONS			
ABSORBENTS FOR FIBERS	Application	Coverage	Quantity	Price
<b>FF-2</b> <b>FDNY</b> <b>CAFM</b>	Instant. For natural fibers with reduced absorbency, such as silk and rayon. One gallon packet has 11½ oz. of chemical.	150-200 sq. ft./ mixed gallon	Packet for 1 gal. Packet for 5 gal. Packet for 50 gal.	22.00 97.00 785.00
<b>FF-3</b> <b>FDNY</b> <b>CAFM</b>	Instant. For natural and synthetic fibers that have good absorbency, such as muslin drops. One gallon packet has 20½ oz. of chemical.	150-200 sq. ft./ mixed gallon	Packet for 1 gal. Packet for 5 gal. Packet for 50 gal.	36.00 165.00 1,308.00
<b>FF-4P</b> <b>FDNY</b> <b>CAFM</b>	Instant. Makes the strongest solution for natural and synthetic fibers, blends and wood. One gallon packet has 33½ oz. of chemical.	150-200 sq. ft./ mixed gallon	Packet for 1 gal. Packet for 5 gal. Packet for 50 gal.	49.00 230.00 1,670.00

DID YOU KNOW?

All our fabrics have a downloadable, sample flame-retardant certificate online. Use these samples to show your local fire inspector before you purchase.

With each shipment of our Flame Retardant fabrics or drapes, Rose Brand includes a copy of the appropriate FR certificate with the shipping documents. For additional or replacement copies of FR certificates email [FRcertificates@RoseBrand.com](mailto:FRcertificates@RoseBrand.com).

Safety Data Sheets (SDS) for chemicals are also available via the website, by phone or by email request. Other useful tips about applying FR chemicals are also online.

If you need to get FR testing done on your draperies or need to clean and retreat your stage curtains, Rose Brand can help you do it yourself or find a local company to do it for you. Call or e-mail for more information. Recommendations on the care and maintenance of your draperies are available as downloads from the Rose Brand website.

With each shipment Rose Brand will send the buyer an email version of the FR certificate automatically. Special New York City suitable FR certificates are issued if the shipping address is to NYC. If you need a NYC version of any FR certificate, place your request with [FRcertificates@RoseBrand.com](mailto:FRcertificates@RoseBrand.com).

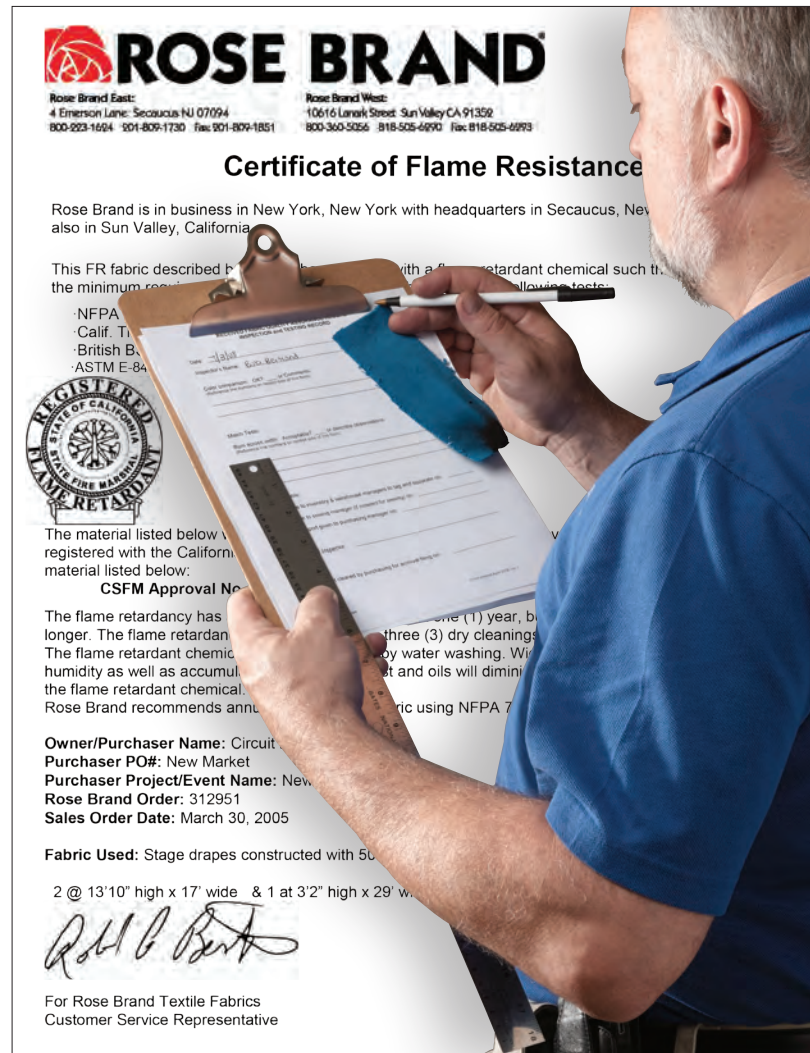

PRODUCT USAGE RECOMMENDATIONS																	
'A' = Approved For Use By Laboratory Testing      'E' = Effective Treatment Based On Field Testing																	
SUBSTRATE	FF-2	FF-3	FF-4 (L&P)	FF-6	RF- NF	RF-SF	RF-DF	RF-PC	RF-WD	MG-702	RF-PA	FR-1	FOAM COAT	FLEX COAT	JAXSAN	AQUA RESIN	
<b>FABRICS</b>																	
Acrylic							A										
Burlap	A	A	A	A	A				A	E							
Cotton	A	A	A	A	A					A							
Duvetyn	A	A	A	A	A					A							
Erosion Cloth											E						
Felt (Wool)	E	E	E	E	E	E				E							
Jute	E	E	A	E	E				A								
Linen	E	E	E	A	A	A	E										
Metallic			A	A			E	E									
Muslin, 1 Side Painted	E	E	E	E	A					E							
Muslin, Unfinished	A	A	A	A	A					A							
Nylon							E										
Polyesters, Selected	A	A	A				A	A									
Polyester/Cotton Blend			A				A	A		E							
Polyester/Rayon Blend			E				A	A		E							
Ramie	E	E	A	E	E	E				E							
Rayon	A	A	A	A	A	A	E			E							
Scrim, Cotton	A	A	A	A	A	A	A			E							
Silk	A	A	A	A		A	A			E							
Velour, Cotton	E			A	A					A							
Velvet, Natural	E	E	E	A	A					A							
Velvet, Synthetic	E	E	E				A	A									
Wool		E	A		A	E				E							
<b>WOOD PRODUCTS</b>																	
Bamboo										E							
Branches																	
Cardboard			E	A				A	E	E							
Cellulose Boards								A	E								
Evergreens																	
Hemp Rope			E						E	E							
Lumber (Raw Wood)			A						A	A					E	E	
Plywood			A						A	A					E	E	
Raffia		E	E	E					E	E							
<b>PAPERS</b>																	
Crepe Paper	E	E	E	E				E	A		E						
Confetti	E	E	E	E				E	A		E						
Maché								E	A				E	E	E	E	
Streamers	E	E	E	E	E			E	A		E						
Tissue	E	E	E	A				E	A		E						
<b>FOAM PRODUCTS</b>																	
Ethafoam														E	E	E	E
Foamcore													E	E	E	E	
Polyurethane Foam													E	E	E	E	
Polystyrene													E	E	E	E	
Styrofoam													E	E	E	E	
<b>OTHER PRODUCTS</b>																	
Artificial Flowers							E	E									
Hay (Immersion Only)			E						A	E							
Leather, Unfinished			E		E					E							
Pre-Painted Surfaces													E	E	E	E	
Spanish Moss			E							E	E						
Paint, Water-Based											A	A					
Paint, Oil-Based																	







Fabrics  
Black Masking  
Custom Stage Curtains & Backdrops  
Custom Special Event Sewing  
Digital Printing  
LED Star Drops  
Pipe & Base  
Rentals  
Projection Materials  
Flooring  
Curtain Track  
Stage Equipment, FXs & Mirrors  
DMX Winches  
Scenery Props  
Shop & Production Supplies  
Tape  
Film & Video Supplies  
Index



Tape



**PURCHASE 2" GAFFER'S TAPE BY THE CASE & SAVE! (24 ROLLS)**

TAPE STYLE	SPECIFICATIONS				PRICE			
	Name	Description	Colors	Roll Size	Per Roll			
<b>GAFFER'S TAPE</b> 	<b>PRO-GAFFER'S</b> 	Economic Vinyl Cloth Matte Finish	Teal, Burgundy, Dk Green, Red, Olive, Blue, White*, Purple, Tan, Grey, Yellow, Brown, Electric Blue, Black <small>30 Yd Roll Black Only * White not available 3"</small>	1" x 55 yds. 2" x 30 yds. 2" x 55 yds. 3" x 55 yds.	8.86 12.05 15.20 23.48			
	<b>PRO-GAFFER'S FLUORESCENT</b>	Brilliant in Ultraviolet Light Vivid in Normal Light	Green, Pink, Yellow, Orange, Blue	1" x 50 yds. 2" x 50 yds. 3" x 50 yds.	9.17 18.44 27.30			
	<b>PRO-GAFFER'S CHROMA KEY GREEN</b> 	Use within green screen environments for repairs, mounting objects, or to tape over and hide elements.	Green	2" x 55 yards	21.75			
	<b>SHURTAPE® A&amp;E P-665</b>	Vinyl Cloth Matte Finish General Purpose	Black, White, Grey <small>30 Yd Roll Black Only</small>	1" x 55 yds. 2" x 30 yds. 2" x 55 yds. 3" x 55 yds.	9.99 10.85 17.10 24.93			
	<b>SHURTAPE® A&amp;E PROFESSIONAL GRADE GAFFER'S</b>	Vinyl Cloth Matte Finish Waterproof	Black, White, Grey <small>25 Yd Roll Black Only</small>	1" x 50 yds. 2" x 25 yds. 2" x 50 yds.	14.47 15.80 24.25			
	<b>CAMO GAFFER'S</b>	Pro-Gaffer's Tape in Camouflage Patterns	Woodland, Desert	2" x 20 yds.	13.13			
<b>NFG TAPE</b> 	<b>NFG TAPE</b>	Printed with NFG every 12" for easy identification. Simply tear off the desired amount and apply to a road box.	Fluorescent Orange	2" x 25 yds.	16.98			
<b>SPIKE TAPE</b> 	<b>CLOTH SPIKE</b>	Economic, Matte Finish Used to Spike Stages and Color Code	Black, Brown, Dk. Blue, Lt. Grey, Dk. Green, Red, White, Electric Blue, Purple, Olive, Burgundy, Yellow, Teal, Tan	½" x 45 yds.	6.14			
	<b>CLOTH SPIKE FLUORESCENT</b>	Brilliant in Ultraviolet Light Vivid in Normal Light	Green, Pink, Yellow, Orange, Blue	½" x 45 yds.	7.51			
<b>PAPER TAPE</b> 	<b>ARTIST'S/ CONSOLE</b>	Premium Paper Tape Markable Leaves No Residue	White	¾" x 60 yds.	5.56			
			Black, Blue, Orange, Red, Yellow, Green	¾" x 60 yds.	5.66			
			White	½" x 60 yds.	4.29			
			Black	1" x 60 yds.	7.65			
<b>ARTIST'S/ CONSOLE FLUORESCENT</b>	Ultraviolet Light Sensitive Paper Tape	Green, Pink, Yellow, Orange	1" x 60 yds.	7.55	8.11			
<b>BLACK MASKING</b>	TV And Film Use Economy Grade	Black	2" x 60 yds.	8.15				
<b>MASKING TAPE</b> 	<b>SHURTAPE® A&amp;E P-743</b>	Photo-Grade Opaque Masking	Ultra-Black Matte	1" x 60 yds. 2" x 60 yds.	11.50 22.95			
			<b>NATURAL MASKING</b>	General Purpose	Natural	¾" x 60 yds. 1" x 60 yds. 1½" x 60 yds. 2" x 60 yds. 3" x 60 yds.	1.73 1.94 2.75 3.83 5.83	
	<b>PRO-SCENIC BLUE MASK™</b>	Professional Grade Low Tack Easy Removal			Blue	1" x 60 yds. 2" x 60 yds. 3" x 60 yds.	5.00 7.75 11.55	
					<b>GLOW TAPE</b>	Continuous Strip	Flexible Vinyl Tape That Glows in Blackout After Exposure to Light. Rechargeable.	1" x 5 yds. 1" x 10 yds. 2" x 10 yds.
	<b>SHURTAPE® A&amp;E GLOW GAFF</b>	Continuous Strip	The great quality of Gaffer's Tape with the luminosity of Glow Tape. 4 additional sizes at RoseBrand.com.	1" x 10 yds. 2" x 10 yds.	16.54 29.40			

**TAPE BARGAINS\***

2" Pro Gaffer's..... 14.10/roll  
 2" Pro Gaffer's Fluorescent..... 16.40/roll  
 2" P-665 ..... 15.90/roll  
 2" Shurtape A&E Professional Grade Gaffer's..... 22.35/roll







*\*Must purchase a full case (24 rolls). One Color Per Case.*



- Fabrics
- Masking
- Custom Stage Curtains & Backdrops
- Custom Special Event Sewing
- Digital Printing
- LED Star Drops
- Pipe & Base
- Rentals
- Projection Materials
- Flooring
- Curtain Track
- Stage Equipment, FXs & Mirrors
- DMX Winches
- Scenery Props
- Shop & Production Supplies
- Tape**
- Film & Video Supplies
- Index



## Tape

TAPE STYLE	SPECIFICATIONS				PRICE
	Name	Description	Colors	Roll Size	
<b>ELECTRICIAN'S TAPE</b> 	<b>ECONOMY GRADE</b>	Vinyl For Wire Splicing Color Coding	Black, Orange, Yellow, Blue, Green, Red, White, Grey, Brown, Purple	¾" x 66 ft.	1.40
	<b>3M-33/3M-35</b>	Premium Grade Minimal Residue	Black, Orange, Yellow, Blue, Green, Red, White, Violet, Grey, Brown	¾" x 66 ft.	6.25
	<b>FRICITION</b>	Coated Cotton Tape For Cable Bonding	Black	¾" x 60 ft.	3.70
	<b>J-LAR GEL REPAIR</b>	Gel Repair Tape, Non-Yellowing Brilliantly Glossy, Clear to the core.	Clear.	1" x 72 yds. 2" x 72 yds.	9.80 19.70
<b>SAFETY TAPE</b> 	<b>SAFETY</b>	OSHA Approved; Vinyl	Black/Yellow	2" x 18 yds.	9.90
	<b>CABLE PATH™</b>	High-Quality Cloth Gaffer's Adhesive on Edges Only Durable and Easy-to-Tear	Black, Yellow, Printed Black on Yellow	4" x 30 yds. 6" x 30 yds.	29.14 43.79
	<b>STRIPED CABLE PATH™</b>	Safety-Striped Gaffer Adhesive on Edges Only	Black/Yellow Stripe	4" x 30 yds. 6" x 30 yds.	29.14 43.79
	<b>BARRICADE</b>	Non-Adhesive 3 Mil Thick	Yellow with "Caution" Printed in Black	3" x 1000 ft.	16.38
<b>DUCT TAPE</b> 	<b>DUCT</b>	Reinforced Poly/Cloth General Purpose	Red, Brown, Green, Blue, Olive Drab, Yellow, Black, Silver, White, Tan, Orange, Burgundy	2" x 60 yds.	8.09
				3" x 60 yds.	12.18
<b>SET TAPE</b> 	<b>DOUBLE SIDED</b>	A unique double sided tape for safe but secure temporary attachment to delicate floors, walls, windows and more - the ideal solution for working in event spaces. One side has a gentle painter's tape adhesive that won't damage or mar sensitive surfaces. The other uses an aggressive carpet tape adhesive to securely hold porous and non-porous materials alike. Use Set Tape on location, in ballrooms, churches and public spaces, or on stage - anywhere a safe but secure attachment is needed.		2" x 20 yds.	18.00
<b>DOUBLE-FACED TAPE</b> 	<b>GENERAL PURPOSE CLOTH</b>	Great All-Around Tape For Conventions, Theater and Multi-Media	White with Blue liner	2" x 25 yds.	10.50
	<b>HIGH TACK/ LOW TACK</b>	High Tack One Side, Low Tack Second Side. Great for Floors.	White	1" x 25 yds. 1½" x 25 yds. 2" x 25 yds.	9.45 13.00 17.75
	<b>PERMACEL P-50®</b>	Premium Grade High Tack Both Sides	White	2" x 25 yds.	28.10
	<b>DOUBLE-COATED FOAM</b>	½" Thick Foam	White	1" x 18 yds. 2" x 18 yds.	16.55 33.00
<b>SPECIALTY TAPE</b> 	<b>DUVE PRO™</b>	Polyester Felt Fabric w/Acrylic Adhesive Quick Repairs on Duvetyn, Commando or Lt.Weight Velour (Special Sizes Available up to 48" Wide)	Matte Black	2" x 5 yds. 3" x 5 yds. 6" x 5 yds. 2" x 25 yds. 3" x 25 yds. 6" x 25 yds.	6.35 9.55 18.15 23.15 34.45 67.65
	<b>DANCE FLOOR</b>	Vinyl, Satin Finish	Black, White, Grey, Clear (Additional Colors Available By Special Order)	2" x 36 yds.	7.35
	<b>PRO SHEEN™</b>	Self-Wound Metallized Film Acrylic Adhesive for Cueing and Splicing	Red, Blue, Green, Black, Silver, Gold, Copper	1" x 36 yds. 2" x 36 yds.	9.10 18.20
<b>PACKING TAPE</b> 	<b>PACKING TAPE PRO919</b>	Economy Grade	Clear	2" x 60 yds.	6.17



Product: Argo® Starch, Rosco Supersaturated™ Paint, Rosco Flexbond™; Miami City Ballet; Designer: Isabel + Ruben Toledo; Scene Shop: Scenic Art Studios

- Fabrics
- Black Masking
- Custom Stage Curtains & Backdrops
- Custom Special Event Sewing
- Digital Printing
- LED Star Drops
- Pipe & Base
- Rentals
- Projection Materials
- Flooring
- Curtain Track
- Stage Equipment, FXs & Mirrors
- DMX Winches
- Scenery Props
- Shop & Production Supplies
- Tape**
- Film & Video Supplies
- Index



Shop Papers

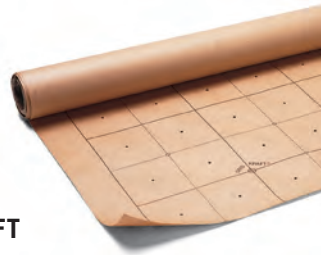

**GRID KRAFT**

A Rose Brand exclusive, Grid Kraft shop paper eliminates the time required to snap out grid lines. Grid registration is printed at 1 ft., 6" & 3" intervals on high quality kraft paper. Ideal for cartooning, patterning and general layout. Actual grid size - 72" wide. Roll has a 2" overlap edge for laying out larger areas.

	Price Per Roll
74" x 340' roll	150.00



**KRAFT PAPER**

All purpose brown shop paper. 50 lb. basis paper weight for maximum durability. All rolls yield approx. 326 linear yards of paper.

	Price Per Roll
24"	37.25
48"	75.00
60"	94.00
72"	115.00

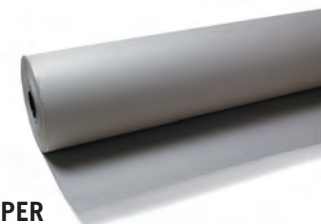

**BOGUS PAPER**

A heavy weight, extra-wide floor liner. Used extensively in scenic art shops under fabric to protect surfaces and to assist in the speedy drying of drops. Grey.

	Price Per Roll
54" Approx. 167 yds. roll	145.00

**SAVE 10%**

**BOGUS PAPER BARGAIN**

5 Rolls or more .....10% Discount



**TUFF MASK**

Also known as Frisket Paper. Heavy-duty adhesive-backed masking paper for spray painting. The low tack adhesive makes the paper easily removable after the paint application has dried. Custom slit widths available up to 48" maximum width.

	Price Per Roll
48" x 100 yd. roll	236.25
48" x 50 yd. roll (with liner)	295.00



**SEMI-WAX PAPER**

Rose Brand's exclusive semi-wax system. Water resistant, won't stick to painted drops or leave behind a waxy residue.

	Price Per Roll
60" x 512' roll	148.00
60" x 1,025' roll	270.00



**POLY SHEETING**

All purpose, clear. (AKA Visqueen) shop grade.

	Price Per Roll
10' x 100' roll, 4mil	55.00
20' x 100' roll, 4mil	85.00
20' x 200' roll, 2mil	85.00
20' x 100' roll, 6mil	120.00



**APPLE BOXES**

Apple boxes are commonly used in the entertainment industry to block up equipment, props and scenery, and even people. Their light weight, strong construction and standard industry sizes make Rose Brand apple boxes a highly useful tool in any production, shop, photo and film studios.

Our apple boxes are made in the USA with quality maple ply.

	Size	Price
HWAP0001	Full 8" x 12" x 20"	35.00
HWAP0002	Half 4" x 12" x 20"	33.00



**DOLLY**

Solid top with handles cut in for easy handling. High capacity casters provide uniform load capacity of up to 3000 lbs.

	Size	Price
	12 1/2" x 32" x 7"	241.80



**SPEED CLIPS**

Allows you to quickly secure a backdrop or overhead rag to pipe without much effort. Simply place the desired fabric against the pipe and snap on the speed clip! In addition, the 1 1/2" clip works on the edge of 2 x 4" lumber and the 1 1/4" clip works on the edge of 5/4" lumber.

	Size	Price
1 1/4"	White, Black, Digital Key Green	5.00
1 1/2"	White, Black, Digital Key Green	6.00



**DRAPE BAG**

Rose Brand's rental drape bags are available for sale (in red only). Made of coated nylon with drawstring closure.

	Size	Price
	30" x 40"	15.00



**CANVAS TRAVEL / STORAGE BAGS**

Made from heavy weight canvas, these sturdy storage bags feature grommet and drawstring construction. Keeps soft goods clean.

	Size	Price
	Standard, 3' H x 2'6" Dia.	55.00
	Small, 2'6" H x 1'8" Dia.	45.00



**QUILTED PACKING WRAP**

Pads and protects scenic elements to be shipped or stored.

	Size	Price
	80"	22.50/yd.
	80" x 25 yd. roll	562.50



**HAMPERS**

Heavy weight canvas hampers with hinged wooden tops, reinforced bottoms and 4" swivel casters (44 Bushel has 5" casters). Ideal for soft goods storage and moving.

Size	L (Top) x W (Top) x Depth	Price
8 Bushel	34" x 22" x 23"	288.75
12 Bushel	36" x 26" x 27 1/2"	335.00
16 Bushel	40" x 28" x 30"	370.00
20 Bushel	44" x 32" x 33"	387.00
24 Bushel	54" x 34" x 30"	499.50
44 Bushel	82" x 31" x 33"	958.75



**U-HOOK RATCHET STRAPS**

Polyester webbing assembly logistic straps.

Size	Color	Rating	Price
1" x 10'	Black	700 lbs.	13.75
1" x 20'	Black	700 lbs.	15.65
2" x 27'	Yellow	1600 lbs.	25.70



**PACKING BLANKET SCENERY COVERS**

Great for protecting scenery in transit or storage. Call us for a quote on custom sizes.



**PACKING BLANKETS**

Excellent for packing scenery. Approx. 72" x 78"

	Price
Set of 2	38.00
Dozen	190.00



**CASTER DONUTS**

Bolt these to hamper lids to allow safe stacking of hampers. Sold in sets of 4.

	Price
Set of 4	18.00

Fabrics
Black Masking
Custom Stage Curtains & Backdrops
Custom Special Event Sewing
Digital Printing
LED Star Drops
Pipe & Base
Rentals
Projection Materials
Flooring
Curtain Track
Stage Equipment, FXs & Mirrors
DMX Winches
Scenery Props
Shop & Production Supplies
Tape
Film & Video Supplies
Index





**POLY PRO WEBBING**

Heavy weight polypropylene webbing. 100 yd. rolls only.

	Price Per Roll
2" Black, White	45.00
3" Black, White	65.00



**JUTE WEBBING**

	Price Per Roll
3 1/2" x 72 yds.	25.00



**STEEL RIBBON WEIGHTS**

	Price
#90S	59.15
#105	59.15

**DID YOU KNOW?**

Grommets		
TRADE	HOLE SIZE	
#2	3/8"	
#3	7/16"	
#4	1/2"	

Lead Tape		
LEAD TAPE	YARDAGE	WGT. PER YD.
#20	100	1.8 oz.
#40	36	5 oz.
#90	25	7.9 oz.
#200	12	10.1 oz.



**STRETCH LOOP**

40 yard rolls only.

Standard		Price
1"	Female Loop Only Black or White	120.00
1 1/2"	Female Loop Only Black or White	140.00
2"	Female Loop Only Black or White	235.00



**GROMMETS & ACCESSORIES**

	Price
#2 Brass Grommets, Plain	11.55/gross
#3 Brass Grommets, Plain	17.00/gross
#4 Brass Grommets, Plain	21.00/gross
#2 Grommet Hole Cutter and Setting Die	90.00/set
#3 Grommet Hole Cutter and Setting Die	105.00/set



**S-HOOKS**

	Price
2" S-Hook	1.90/dz
1" S-Hook	1.10/dz



**CHAIN**

	Price
#8 Plated Jack Chain	.75/ft
#10 Plated Jack Chain	.63/ft
#8 Stainless Steel Chain	3.50/ft



**LEAD TAPE**

	Price
#20 Lead Tape, 100 yds.	180.00/reel
#40 Lead Tape, 36 yds.	98.00/reel
#90 Lead Tape, 25 yds.	118.00/reel
#200 Lead Tape, 12 yds.	140.00/reel



**HOOK AND LOOP**

25 yard rolls only. Black or White.

	Std.	Pressure Sensitive
3/4" Male Hook or Female Loop	12.25	23.00
1" Male Hook or Female Loop	14.90	27.50
2" Male Hook or Female Loop	29.50	47.50
1" Acrylic Male Hook or Female Loop	N.A.	28.75
2" Acrylic Male Hook or Female Loop	N.A.	62.50



**LOW PROFILE PRESSURE SENSITIVE HOOK & LOOP**

Ultra-low profile hook and loop tape is virtually undetectable. Less than 1/16" clearance. White loop (female). Clear hook (male).

	Price
1" Set of Male & Female - 25 yds.	119.95



**BLANKET PINS**

Perfect for pinning back draperies. No hardware kit should be without. Caution: May leave large holes in fabric.

	Price Per Dozen
	7.00



**ELEPHANT EARS**

Inside dimensions 2 1/2" x 1/2" at the smallest point

	Price
	1.80



**TIE LINE**

Also known as "trick" line, #4 Tie Line is available in hanks or reels of various sizes.

Prices are for coated Tie Line. Uncoated Tie Line available in 600' and 3000' reels.

	Size	Price Per Unit
96' Natural	#4	8.25/Hank
96' Black	#4	9.60/Hank
600' Natural	#4	43.65/Reel
600' Black	#4	43.65/Reel
3000' Natural	#4	143.30/Reel
3000' Black	#4	143.30/Reel

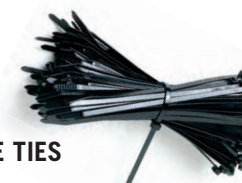

**NYLON CABLE TIES**

7" long. Black.

	Price
Pack of 100	6.00



**ONE-WRAP STRAPS**

A unique back-to-back Velcro® fastening system. Black, White.

	Price
Die Cut 50 pcs. 1/2" W x 8"L	25.00
Die Cut 900 pcs. 1/2" W x 8"L	255.00
Die Cut 50 pcs. 1/2" W x 12"L	25.00
Die Cut 600 pcs. 1/2" W x 12"L	255.00
25 yd. continuous roll 1/2" W	26.25



**RIPPLEFOLD® TAPE**

Make your own Ripplefold® Curtains.

	Price Per Yard
	3.85



**BUNGEE CORD**

Available in solid black and solid white.

	Price
5/16" x 250' Black	55.00
5/16" x 250' White	50.00
1/4" x 250' Black	45.00
1/4" x 250' White	40.00



**HOLDON™**

A quick temporary attachment that functions like a grommet. For lightweight fabrics use the Mini and for heavier fabrics use the Midi. No tools required. Sold in packs of 10 in either black or white.

	Price
Mini	11.00
Midi	16.00



**PIPE SNAP**

Clever, self-loading clamp for fast mounting and relocation of theatre legs, borders and backdrops. Tube max diameter 2 1/4". Complete with swiveling hook. Available in Black and White. Load 33 lbs.

	Price
	5.00



**CABLE GUIDE CLIPS**

For drapes, scrims and backdrops to help correct hour-glassed edges; can accommodate up to 3/16" cable. Clips are 1 1/4" long.

	Price
Pack of 10	18.05



**JIB CLAMP**

Heavy duty clamp to help correct hour-glassed edges of drapes, scrims and backdrops. Traditionally used with 1/8" cable. Available Black and White.

	Price
	6.95



Bungee with Ball and Hook



Bongo Ties

**MULTI-PURPOSE FASTENERS**

Maintain constant tension between screens and supporting structures. Bongo Ties are approx. 5" long; Stretch-N-Hook are approx. 10" long.

	Price
Bongo Ties Set of 10	6.99
Bungee with Ball & Hook	18.00/dz



**SPRING CLAMPS**

Convenient clamps to hold any material quickly and efficiently. Hand pressure spreads jaws to grip work. Use wherever relatively light pressure is adequate and where speedy application and removal are important.

	Price
1"	3.25
2"	5.00
3"	9.00
4"	15.40



# Film & Video Supplies

Masking .....346  
Diffusions .....347  
Backdrops .....348  
Keying .....349



Fabrics
Black Masking
Custom Stage Curtains & Backdrops
Custom Special Event Sewing
Digital Printing
LED Star Drops
Pipe & Base
Rentals
Projection Materials
Flooring
Curtain Track
Stage Equipment, FXs & Mirrors
DMX Winches
Scenery Props
Shop & Production Supplies
Tape
Film & Video Supplies
Index



# Masking

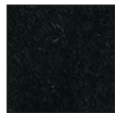

Commando Black

COMMANDO								
FABRIC	SPECIFICATIONS				PRICE PER YARD			
	Width	Weight	Color	Description	Approximate Roll / Piece Size	Cut	Full Piece	500+ yds.
<b>FR COMMANDO 100% COTTON</b>	54"	16 oz.	Black	Known on the West Coast as Duvetyn. The most widely used black masking fabric in the entertainment industry.	50 or 100 yds.	9.20	5.25	4.95
	60"	16 oz.	Black	5' width saves sewing time and prevents waste on many common sizes of finished backings.	50 or 100 yds.	11.20	8.00	6.90
	78"	16 oz.	Black	Extra width allows for fewer seams.	50 or 100 yds.	19.50	13.00	11.25
<b>FR DOUBLE FACED COMMANDO 100% COTTON</b>	118"	18 oz.	Black	Brushed finish on both sides. Extra width allows for 9' seamless panels. Cut yardage may be folded for UPS shipping.	65 yds.	22.50	15.00	13.50
<b>62" IFR COMMANDO</b>	62"	16 oz.	Black	Permanently flame resistant alternative to regular commando. Narrow width. Not compatible with 118".	50 - 60 yds.	12.75	8.75	7.60
<b>118" IFR COMMANDO</b>	118"	16 oz.	Black	Permanently flame resistant alternative to regular commando. Wide width. Not compatible with 62".	50 - 60 yds.	27.50	21.95	17.20
<b>FR LIGHTWEIGHT COMMANDO 100% COTTON</b>	54"	12 oz.	Black	Between 8 oz. Duvetyn and 16 oz. Commando Cloth in weight. Ideal for Backdrops on a limited budget.	50 or 100 yds.	7.50	5.00	4.25
	118"	12 oz.	Black	Cut yardage may be folded for UPS shipping.	50 - 70 yds.	18.48	14.45	12.75



Duvetyn Black

DUVETYN								
FABRIC	SPECIFICATIONS				PRICE PER YARD			
	Width	Weight	Color	Description	Approximate Roll / Piece Size	Cut	Full Piece	500+ yds.
<b>FR DUVETYN 100% COTTON</b>	54"	8 oz.	Black	The most economical masking fabric available. With a brushed matte finish. For masking below stages and other areas where there is no light source behind the material.	50 or 100 yds.	6.75	4.50	3.85
<b>FR DUVETYN EXTRA WIDE 100% COTTON</b>	118"	8 oz.	Black	Cut yardage may be folded for UPS shipping.	65 yds.	13.57	10.60	9.55

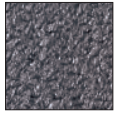

HD Grey

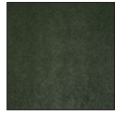

Encore Black

VELOURS								
FABRIC	SPECIFICATIONS				PRICE PER YARD			
	Width	Weight	Color	Description	Approximate Roll / Piece Size	Cut	Full Piece	500+ yds.
<b>IFR ENCORE</b>	62"	15 oz.	Black	Lightweight brushed polyester. Drapes beautifully.	60 yds.	17.53	13.50	
<b>IFR ENCORE</b>	64"	22 oz.	Black	Medium weight brushed 100% polyester. Totally opaque, durable and wrinkle resistant. Ideal for outdoor venues and high humidity climates.	65 yds.	22.23	18.50	
<b>IFR HD GREY™</b>	62"	15 oz.	HD Grey	Developed specifically as a "Night Grey" masking fabric with all the soft, matte properties of a typical velour or duvetyn.	60 yds.	17.53	13.50	

BLACKOUT, BOUNCES & REFLECTORS								
FABRIC	SPECIFICATIONS				PRICE PER YARD			
	Width	Color	Properties	Approximate Roll / Piece Size	Cut	Full Piece	500+ yds.	
<b>IFR LITEOUT</b>	120"	Black	The lightest weight IFR blackout fabric available. Can be used as a liner or as a stand-alone blackout. Water and tear resistant.	54 yds.	35.00	25.00		
<b>IFR LITEOUT B/W</b>	122"	Black/White	Black on one side for blackout, white reverse side for superior projection. Significant sound blocking.	54 yds.	39.00	29.00		
<b>FR JD CLOTH</b>	60"	Black/White	Black/White opaque. Coated for weather proofing. Use as a bounce or blackout.	100 yds.	15.00	12.75		
<b>NFR UNDERWATER BLACK</b>	60"	Black	Color safe for use in pools and tanks.	50 yds.	10.00	8.50		
<b>NFR NUGGET LAME</b>	58"	Gold, Silver	Used as a reflective fabric. The Gold typically gives off a warming effect.	80 yds.	12.25	7.00		
<b>NFR RICOCHET</b>	60"	Black/Pewter	Black/Pewter opaque ripstop. Coated for weather proofing. Soft bounce reflector provides a flattering fill, or flip and use as blackout.	100 yds.	13.00	11.00		

HEAT SHIELDS								
FABRIC	SPECIFICATIONS				PRICE PER YARD			
	Width	Color	Properties	Approximate Roll / Piece Size	Cut	Full Piece	500+ yds.	
<b>FR AMI-SIL</b>	35"	Tan	Rose Brand's version of Refrasil, this heat protective cloth provides continuous protection to 1800°F.	50 yds.	23.12	19.65		
<b>FR AMI-SIL</b>	35"	Black	Rose Brand's version of Refrasil, this heat protective cloth provides continuous protection to 1800°F.	50 yds.	34.50	27.60		
<b>FR KEVLAR</b>	40"	Black	Black heat shield providing continuous protection to 600°F.	50 yds.	27.47	23.35		

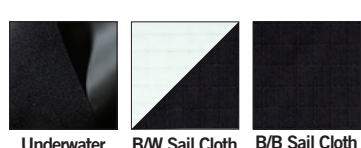
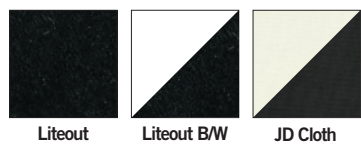

# Diffusions

DIFFUSIONS					
FABRIC	SPECIFICATIONS			PRICE PER YARD	
	Width	Color	Approximate Roll / Piece Size	Cut	Full Piece
<b>FR ARTIFICIAL SILK (FULL SILK)</b>	60"	White, Black	50 yds.	8.97	6.90
<b>IFR ARTIFICIAL SILK (FULL SILK) ALLEGRO</b>	119"	White	65 yds.	14.65	9.75
<b>IFR ARTIFICIAL SILK (FULL SILK) POLY SILK PLUS</b>	125"	White	135 yds.	12.90	10.30
<b>IFR ARTIFICIAL (FULL SILK) SUPERSILK</b>	16'6"	White	65 yds.	30.80	22.00
<b>NFR CHINA SILK (HALF SILK)</b>	54"	White, Black	55 yds.	15.65	12.50
<b>FR CHINA SILK (HALF SILK)</b>	54"	White, Black	55 yds.	18.65	15.50
<b>IFR QUARTER STOP SILK</b>	118"	White	60 yds.	6.30	5.25
<b>IFR QUARTER STOP SILK TREVIRA</b>	139"	White	55-70 yds.	35.00	28.00
<b>FR SNAPSHOT</b>	60"	White	100 yds.	13.00	11.00
<b>FR PHOTOSCREEN (USED FOR LIGHT BOXES)</b>	60"	White	50 yds.	15.00	12.00

SAIL CLOTH					
FABRIC	SPECIFICATIONS			PRICE PER YARD	
	Width	Color	Approximate Roll / Piece Size	Cut	Full Piece
<b>NFR FULL GRID</b>	60"	White	100 yds.	7.00	6.00
<b>NFR HALF GRID</b>	60"	White	100 yds.	7.00	6.00
<b>NFR QUARTER GRID</b>	60"	White	100 yds.	16.00	12.80
<b>NFR FULL GRID SILENT</b>	60"	White	100 yds.	7.00	6.00
<b>NFR HALF GRID SILENT</b>	60"	White	100 yds.	7.00	6.00
<b>NFR QUARTER GRID SILENT</b>	60"	White	100 yds.	12.00	9.60
<b>FR B/W SAIL CLOTH</b>	60"	Black/White	100 yds.	11.85	9.85
		Black/Black	100 yds.	10.52	8.95
<b>FR SPINNAKER (FULL GRID)</b>	122"	White	55 yds.	17.50	14.00
	16'4"			27.50	22.00

CINENET					
FABRIC	SPECIFICATIONS			PRICE PER YARD	
	Width	Color	Approximate Roll / Piece Size	Cut	Full Piece
<b>FR SINGLE CINENET</b>	72"	Black, White	35 yds.	37.05	29.65
	144"	Black, White	35 yds.	68.90	55.10
	216"	Black, White	35 yds.	101.35	81.10
	288"	Black, White	35 yds.	125.70	102.00
<b>NFR LAVENDER NYLON NET</b>	330"	Black	50 yds.	144.38	117.50
<b>FR DOUBLE CINENET</b>	108"	Lavender	50 yds.	2.40	2.05
<b>FR DOUBLE CINENET</b>	240"	Black	19-24 yds.	N.A.	230.98
<b>IFR TEXTILENE®</b>	98"	Black, White	60 yds.	24.00	16.00

SHARKTOOTH SCRIM			
FABRIC	Width	Color	Approximate Roll / Piece Size
<b>FR SHARKTOOTH SCRIM</b>	10'9"	All available Black, White * Day Grey, Night Blue † Day Blue	60 yds.
	15'6"		
	19'6"		
	25'		
	31'*		
	35'†		
	39'		

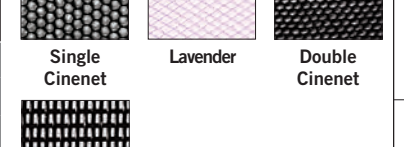
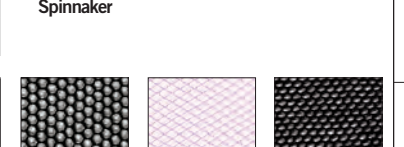
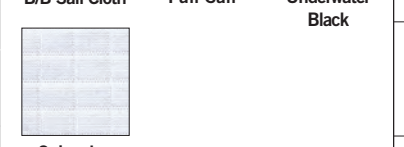
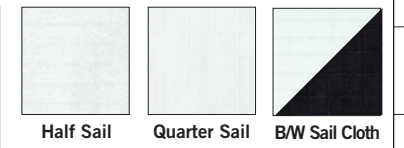
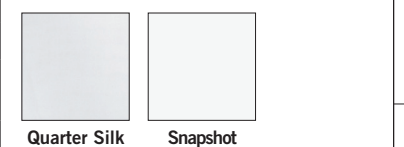



# Backdrops & Expendables

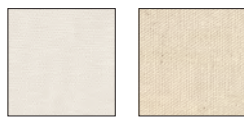

Bleached White Unbleached **MOST POPULAR** FR MOVIE MUSLIN

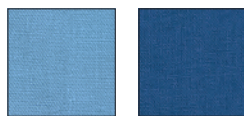

Day Blue Night Blue

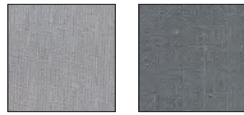

Day Grey Night Grey



Black

For other Muslin widths see pages 54, 56, and 57.



Bleached White Unbleached

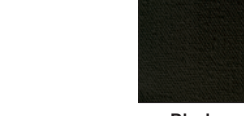

Black



FR MOVIE MUSLIN					
FABRIC	SPECIFICATIONS				Approximate Roll / Piece Size
	Width	Weight	Color		
FR MOVIE MUSLIN	108"	Movie Weight	Bleached White, Unbleached, Day Blue, Night Blue, Day Grey, Night Grey, Black		100 yds.

HEAVYWEIGHT MUSLIN					
FABRIC	SPECIFICATIONS				Approximate Roll / Piece Size
	Width	Weight	Color		
NFR MUSLIN	108"	Heavy	Unbleached, Bleached White		100 yds.
	120"	Heavy	Unbleached		100 yds.
	140"	Heavy	Unbleached		100 yds.
	12'	Heavy	Unbleached		65 yds.
	21'	Heavy	Unbleached		65 yds.
	32'9"	Heavy	Unbleached		65 yds.
	39'0"	Heavy	Unbleached		65 yds.
FR MUSLIN	98"	Heavy	Unbleached		100 yds.
	110"	Heavy	Unbleached		125 yds.
	126"	Heavy	Unbleached, Bleached White, Black, Day Grey		65 yds.
	12'	Heavy	Unbleached, Bleached White, Black, Day Blue, Day Grey		65 yds.
	21'	Heavy	Unbleached, Bleached White, Black, Day Blue, Day Grey		65 yds.
	32'9"	Heavy	Unbleached, Bleached White, Black, Day Blue, Day Grey		65 yds.
	39'0"	Heavy	Unbleached, Bleached White, Day Blue, Day Grey		65 yds.

CANVAS					
FABRIC	SPECIFICATIONS				Approximate Roll / Piece Size
	Width	Weight	Color		
NFR CANVAS	72"	7 oz. (#16)	Unbleached		125 yds.
	128"	10 1/2 oz. (#14)	Unbleached		100 yds.
	72"	12 oz. (#12)	Unbleached		100 yds.
	84"	12 oz. (#12)	Unbleached		100 yds.
	120"	12 oz. (#12)	Unbleached		50 yds.
FR CANVAS	144"	12 oz. (#12)	Unbleached		50 yds.
	108"	6 oz.	Bleached White		55 yds.
	68"	7 oz. (#16)	Unbleached		100 yds.
	70"	12 oz. (#12)	Unbleached		100 yds.
	68"	8 oz.	Black		100 yds.
	68"	15 oz.	Black		100 yds.

TAPE						
ITEM	SPECIFICATIONS				Roll Size	Price Per Roll
	Color	Description				
GAFFER'S TAPE <b>MOST POPULAR</b>	Black, White, Grey	Vinyl coated cloth tape		2" x 55 yds.	15.20	
DUVE PRO™ REPAIR TAPE <b>MOST POPULAR</b>	Matte Black	Polyester Felt Fabric w/Acrylic Adhesive Quick Repairs on Duvetyn, Commando or Lt. Weight Velour (Special Sizes Available up to 48" Wide)		2" x 5 yds.	6.35	
				3" x 5 yds.	9.55	
				6" x 5 yds.	18.15	
				2" x 25 yds.	23.15	
				3" x 25 yds.	34.45	
				6" x 25 yds.	67.65	

FILM & VIDEO SANDBAGS			
ITEM	Description	Size	Price
FILM & VIDEO SANDBAG <b>MOST POPULAR</b>	Constructed from Cordura, equipped with one carry handle. Other sizes and styles available by special order.	15 lbs	41.00
		25 lbs	45.00

# Keying

KEYING FABRICS								
FABRIC	SPECIFICATIONS					PRICE PER YARD		
	Width	Weight	Color		Description	Approximate Roll / Piece Size	Cut	Full Piece
IFR POLY PRO <b>MOST POPULAR</b>	62"	Medium	CK Blue, CK Green, DK Blue, DK Green		Preferred by major movie studios (matte finish, wrinkle resistant).	62 yds.	14.05	11.25
IFR RB CLOTH	72"	Medium	CK Blue, CK Green, DK Blue, DK Green		Woven fabric; excellent color consistency	90 yds.	12.75	8.50
IFR POLY CYC	128"	Medium	CK Blue, CK Green, DK Blue, DK Green		Wide Width. Good for Cycloramas.	120 yds.	16.50	11.00
IFR POLY MUSLIN	128"	Medium	CK Blue, CK Green, DK Blue, DK Green		Good substitute for cotton muslin.	115 yds.	16.50	11.00
NFR KEYING SPANDEX	92"	Heavy	CK Blue, CK Green, DK Blue, DK Green		Can be stretched & molded. Ideal for wardrobe or underwater shots. Matte side to camera.	50 yds.	48.95	37.65
IFR TENDO	122"	Medium	CK Blue, CK Green, DK Blue, DK Green		Four way stretch in a medium weight.	100 yds.	35.00	25.00

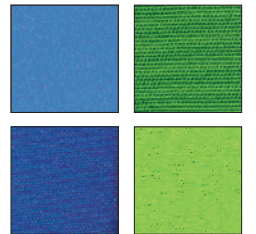

KEYING TAPE					
ITEM	SPECIFICATIONS			Size	Price
	Color	Description			
POLY PRO TAPE	CK Blue, CK Green, DK Blue, DK Green	Match this tape with our Chroma and Digital Key Blue and Green Poly Pro for a perfect fit.		2" x 10 yds.	22.00
				2" x 20 yds.	37.90
				4" x 10 yds.	44.00
				6" x 10 yds.	66.00
PRO-GAFFER'S <b>NEW</b>	Chroma Key Green	Use within green screen environments for repairs, mounting objects, or to tape over and hide elements.		2" x 55 yds.	21.75
				3" x 55 yds.	33.32



KEYING FLOORING							
ITEM	SPECIFICATIONS				Approx. Roll Size	Cut Price	Full Roll
	Color	Description					
ROSCO BLUE/GREEN CHROMA FLOOR	CK Blue/CK Green	Rosco's Chroma Floor solves the long-standing problem of repainting your studio floors for every shoot. Chroma Key Blue on one side and Chroma Key Green on the other make Chroma Floor an ideal addition to any studio. Precise color matching with Rosco Chroma Key paints allows for seamless compositing. Manufactured of lightweight portable vinyl, the floor is easy to install, easy to clean and easy to maintain. Chroma Floors are also great for location shots.		131 ft	21.95	1,695.00	



KEYING PAINT						
ITEM	SPECIFICATIONS				Size	Price
	Color	Description				
CHROMA KEY	CK Blue	Formulated to provide high luminance values and color saturation for keying effects, Chroma Key paints are water-based and feature one coat coverage.		Gallon	91.70	
CHROMA KEY	CK Green			Gallon	91.70	
TV PAINT	White	Specifically formulated for the sensitive requirements of standard television systems, these versatile acrylic paints can be applied to a variety of surfaces. T.V. white and black can be mixed in stepped proportions to achieve multiple grey scale values. TV White is a light neutral grey that meets specifications for 60% reflectance, the maximum brightness for use in video white balancing. TV Black is a rich matte black which meets specifications for 3% reflectance, the minimum brightness intended for transmission balancing.		Gallon	55.40	
	Black			Gallon	55.40	
DIGICOMP HD	DigiBlue	Designed to allow seamless compositing for film, video and digital use. Ideal for a wide variety of uses both in the studio and on location.		Gallon	102.00	
	DigiBlue			5 Gallon	473.80	
	DigiGreen			Gallon	133.40	
	DigiGreen			5 Gallon	602.55	



- Fabrics
- Black Masking
- Custom Stage Curtains & Backdrops
- Custom Special Event Sewing
- Digital Printing
- LED Star Drops
- Pipe & Base
- Rentals
- Projection Materials
- Flooring
- Curtain Track
- Stage Equipment, FXs & Mirrors
- DMX Winches
- Scenery Props
- Shop & Production Supplies
- Tape
- Film & Video Supplies
- Index



# Discount Store Online

Bargain hunters rejoice! Visit our Rose Brand Discount Store Online at <http://bit.ly/RB-discounts>

The Discount Store offers incredible bargains with items priced at 50-75% off regular prices. Products are added frequently and don't last long so check back often.

You'll find a broad collection of products, many of which are one-of-a-kind offers. Our selection varies but includes fabric remnants, closeouts, ready-made curtains, seconds, as well as non-fabric items.\*

Follow Rose Brand on Twitter and be the first to know about new discounted items. We tweet new items as they're listed.

 @RoseBrand

 How Donyale Werle, Tony Award-winning Scenic Designer, Uses The Rose Brand Discount Store



\*Since Rose Brand cannot be sure of the date of manufacture of FR fabrics and draperies, flame retardant certificates will not be issued for remnant purchases. All sales on closeouts and remnants are final.

Fabrics
Black Masking
Custom Stage Curtains & Backdrops
Custom Special Event Sewing
Digital Printing
LED Star Drops
Pipe & Base
Rentals
Projection Materials
Flooring
Curtain Track
Stage Equipment, FXs & Mirrors
DMX Winches
Scenery Props
Shop & Production Supplies
Tape
Film & Video Supplies
Index



# Index / Ordering Information

Rose Brand prides itself on having the best customer service in the industry. You'll see a listing of our sales and customer service representatives on the following pages.

**To Order:**

**Call** 800-223-1624

**Visit** [RoseBrand.com](http://RoseBrand.com)

**Questions or Concerns:**

**Call** 800-223-1624

**Email** [customerservice@rosebrand.com](mailto:customerservice@rosebrand.com)

To find any product in our catalog, use the index that appears in this section. If you don't see what you're looking for, contact us so that we can consider carrying the product in the future or suggest a suitable alternative.

We thank you for your consideration and your business.

Hablamos Inglés y Español, Nuestros representantes estarán encantados de atenderle.



Fabrics
Black Masking
Custom Stage Curtains & Backdrops
Custom Special Event Sewing
Digital Printing
LED Star Drops
Pipe & Base
Rentals
Projection Materials
Flooring
Curtain Track
Stage Equipment, FXs & Mirrors
DMX Winches
Scenery Props
Shop & Production Supplies
Tape
Film & Video Supplies
Index



Product	Page #
<b>A</b>	
Absorbents For Fibers, Flame Retardants	333-334
Acoustical Fabrics	134-137
Acoustical Foam	137
Acrylic Glazes, Rosco	327
Adagio Floor, Rosco	256, 261
Adagio Tour, Rosco	256, 261
ADC 132/220/113 Track	285
ADC 140 Rig-I-Flex Track	284
ADC 170/260 Track	282-283
ADC 280 Silent Steel Track	229, 280-281
ADC Draw Curtain Machines	286
ADC Logistop	286
ADC Model 1483UNI Wall Bracket	287
ADC Track	280-286
ADC Track Wall Bracket	287
Adhesives	326
Adhesives, Primers & Coatings	326-327
Adjustable Beam Clamps	HW
Adjustable Uprights	212-213, 217
Aglo	78, 243
Air Flow Fabric	76
Aircraft Cable	HW
All Purpose Floor Cleaner, Rosco	260
Allegro Silk	95, 243, 347
Allen, Wrench	HW
Aluminum Strut Channel	HW
Alyssa	109
Ami-Sil	346
Angle Mounted Crown, Pipe & Base 2.0	214
Animation Curtains/Waterproof	207
Apollo Velour	40, 49, 51, 134
Apple Boxes	340
Aqua Resin	327
Arena Cloth	31, 49
Argo Starch	326
Artist's /Console Tape	336
Artist's Choice Paint	324
Artist's Choice Paint Test Kit	324
Athena	37, 49, 134
Augusta	104
Austrian Curtain	146, 225
Avora Lining	45
Avora Polyester	45
<b>B</b>	
Backdrop, Overhead & Butterfly Fabrics	348
Backdrops, Custom Sewn	140-157
Bags, Travel	HW
Bail Cap, Pipe & Base	211
Ballare Dance Floor	252, 261
Ballet Studio Floor	254, 261
Banjo Cloth	127
Barricade Tape	338
Barrier & Climbing Nets	70
Base Bag	218
Base Coats & Primer	326-327
Base Plate Boxes	218
Base Sand Bag	219
Bases	212, 216
Basic White or Grey, Screen Goo	245
Batiste	91
Batten Cap	HW
Batten Clamp	HW
Batten Pipe Hardware	HW
Beads by the Roll	317
Beads, Metal	174-175, 317
Beam Clamps, Adjustable	HW
Beam Clamps, Strut	HW
Bending, Custom	289
Besteel, ADC 170 Series	282-283
Bijou	97
Binder Samples	138
Black Masking Fabrics	346-347
Black Masking Tape	336
Black/White Sail Cloth	81, 132, 347
Blackout Lining	45, 243
Blackout Sateen	80, 243
Blackout Satin	45, 108
Blade, Rope Cutter	HW
Blanket Pins	342
Blankets, Packing	341
Blizzard Series Stretch Shapes	186
Blow Through	59, 81, 243

Blue Masking Tape	336
Bluewater	HW
Bobbinette	58, 62
Bogus Paper	340
Bongo Ties	343
Boost, Stretch Fabric	75, 181, 243
Bottom Finishes, Curtain	152
Bottom Hanging Iron	HW
Bottom Pipe	249
Bounces, Reflectors	343
Box Pleat Fullness	148-149
Box Pleats	148
Box-O-Rags	329
Brail Lift Curtain	147, 158
Brava Velour	41, 49, 134
Brick Panels, Vacuform	310
Brick Pattern Seamless Paper	315
Brushes, Paint	330
Bucket Sling	HW
Budget Liner	126
Bullion Tassels, Classic Theatre	155
Bungee Cords	343
Bunting	132
Burlap	67, 122
Burlap Colors	67, 122
Burn Sample Testing	152
<b>C</b>	
Cable Accessories/Wire Rope	HW
Cable Cutters	HW
Cable Guide Clips	343
Cable Hem	151
Cable Management	WEB
Cable Path Tape	338
Cable SRL, 30'	WEB
Cable Ties	343
Cable, Aircraft	HW
Cablesafe Safety Hook	WEB
Cam Cleats	HW
Camo Gaffers Tape	336
Camo Netting	315
Covers, Pipe & Base	187
Covers, Scenery Blanket	341
Canvas Colors	53
Canvas Travel/ Storage Bags	341
Carabiners	HW, WEB
Carpet Custom Inlay	265
Carpet Runners	265
Cartmaster Casters	HW
Casein Paint, see Iddings	323
Cases, Road	218
Caster Donuts	341
Caster Release Plate	HW
Casters	HW
Casters, Stagmaster	HW
Ceiling Fabric, see Melt Out	77, 130
Ceiling Plate with Ring	HW
Celebration Cloth	128
Celtic Cloth	78, 243
Celtic Cloth, Heavyweight	78
Chain	342
Chain Curtains	168-169
Chain Hoists	HW
Chain Rail, Triple E	278
Chainbeam, Triple E	277
Chainette Tassels & Fringe	154-157
Chaintrack, Triple E	277
Chair Tie-Back Tassels	156-157
Chalk Bag	HW
Chameleon ShowLED	204-205
Chameleon™ Scrim	235
Charcoal, Artist's	329
Charisma Velour	30, 49, 134
Charm	105
Cheeseborough	HW
Cheesecloth	66
Chenille	40
Chevy Metal	115
Chicago Hardware	HW
Chiffon	88
Chiffon Substitute, see Voile	83
China Silk	97, 347
Chincha	66
Chip Brushes	330
Christmas Bow Wrap	313, 315
Chroma Key Dance Floor	258, 261, 349
Chroma Key Fabrics	349

Chroma Key Green	
Pro Gaffer's Tape	336, 349
Cinder Block Panels, Vacuform	310
Cinemet	58, 347
Circle Wall	183
Circles, Stretch	184
Clamps	343
Class 1 Manila Rope	HW
Classic ShowLED	202-203
Cleasers, Floor	260
Clear Acrylic Glazes, Rosco	327
Clear Gloss and Clear Flat Acrylics	327
ClikMagnet	186
Climb Spec Webbing Runner	HW
Clips, Cable Guide	343
Clips, Drape	214
Clips, Wire Rope	HW
Closeout Fabrics	WEB
Cloth Spike Tape	336
CM Lode Star Motor	HW
CM Motor	347
CM Prostar Motor	HW
Coatings, Adhesives & Primers	326-327
Cobblestone Panels, Vacuform	310
Coffin Lock	HW
Coffin Lock Key	HW
Columns, Hoop	182
Commando Cloth	46, 49, 346
Compression Dies	HW
Confetti	296, 314
Confetti Drop	296
Connection Hardware	HW
Console Tape	336
Controllable Rotator	297
Controller	203
Cool White Projection	236
Cord, Decorative	154-157
Cordura	80, 132
Corner Casters	HW
Cotton Scrim	66, 122
Cotton Velour	42-43
Couplers	HW
Covers, Pipe & Base	187
Covers, Scenery Blanket	341
Cracked Ice Rain Curtains, Vinyl	177
Crackle Tendo	75, 181
Crescent Velour	30, 49, 50, 134
Crown, Pipe & Base 2.0	211
Crushed Elegance	99
Crushed Gloss Satin	102
Crushed Satin	104
Crushed Trevira Silk	96
Crushed Velvet	40
Crushed Voile	91, 243
Crystal	85
Crystal Gel	327
Crystal Vel	31
Cueable DMX Lift	303
Cup Swivel Caster	HW
Curtain Controller, Hudson	WEB
Curtain Finishes	150-152, 249
Curtain Fullness, pleats	148-149
Curtain Inspection	158
Curtain Track	266-288
Curtain Track Motors	286
Curtains	146-157
Curtains, String	170-173
Curved Pipe & Base	217
Curved Track, ADC 170 Series	282
Curved Wall	185
Custom Carpet	265
Custom Dyed Extra-Wide Muslin	50, 56
Custom Hardware Components	289
Custom Jacquard Fabrics	166-167
Custom Non-DMX Roll Drum	299
Custom Projection Screens	236-241
Custom Rain Curtains	177
Custom Special Event Sewing	160-187
Custom Stage Curtains & Backdrops	140-157
Cut Drops, see Scenery Net	59, 64
Cutting Die	HW
Cyc, Muslin & Canvas Fabric	53-57
<b>D</b>	
D Ring and Keeper Plate	HW
Dacron Snow	314

Daisy Chains Webbing	WEB
Dance Floor Tape	338
Dance Mirror	307
Dance Studio Floor	252-258
Dance, Expo Floor & Event Carpet	252-264
Darknet™ Projection Fabrics	234-235
Darnell-Rose Casters	HW
DC Motor with DMX	303
Deck Chain	HW
Deco Crown, Pipe & Base 2.0	211
Decorative Finishes	328-329
Decorative Rope	154-157
Design, Specify & Build Services	16-25
Designer Rain Curtain	176-179
Designer String Curtain	172
Designer Trim	154-156
Designer Vinyl by the Roll	177
Design-Weight Fringe	154-157
Diffraction Rain Curtains, Vinyl	177
Diffusion Fabrics	347
Diffusion Screen	237
Diffusion Silks	347
Digicomp Paint	349
Digital Printing	188-199
Digitally Printed Fabric by the Yard	92, 194
Dimensional Shapes	180-185
Directional Sign Base	WEB
Disco Ball	316, 317
Discount Store Online	350-351
Display Felt	132
Display Walls	185
DJ Rotator	297
DMX Column Lift	303
DMX Controller ShowLED	WEB
DMX Mini Motor	303
DMX Mini Roll Drum	299
DMX Roll Drum	298-299
DMX Rotator	297
DMX Scenery Rotator	297
DMX Scenery Rotator LX	297
DMX Winches	300-302
Dolce Plus™ Floor	254, 261
Dolce™ Floor	254, 261
Dolly	340
Dolly, Mega-Truss	HW
Domino	115
Doral, see Duval	WEB
Double Cinemet	347
Double Faced Commando Cloth	46, 346
Double Faced Curtain	153
Double Faced Screen	79
Double Faced Tape	338
Double Pulley	HW
Double-Coated Foam Tape	338
Double-Ended Gripper	HW
Double-Sided Low Tack Tape	338
Drape Bag	152, 341
Drape Box	218
Drape Clips	214
Drape Supports	210-213, 217
Drapery Fabrics	28-43
Drapery Hooks	151
Drapery Motors, ADC	286
Drapes, Rental	224-225
Draw Curtain Motor	278, 286
Drizzle	109
Drop System, Kabuki	228, 294-295
Dual Lock	HW
Dual Wheel Casters, 30 Series	HW
Duct Tape	338
Duet	119
Durastron	HW
Dura™ Floor	252, 261
Duval	WEB
Duve Pro Tape	338, 348
Duvetyn	46, 346
<b>E</b>	
E Rail, Triple E	270-271
Easel	WEB
Eclipse Satin	102
Eco Liner	126
EEE Track	270-277
Electric Rope Cutter	HW
Electrician's Tape	338

Elegance	99
Elephant Ear	151, 342
Eliza	101
Embossed Crystal	85
Empress Velour	34, 51
Enclosed Scenery Motor with Shaft	303
Encore Velour	33, 49, 134-135, 346
Endura 12	HW
E-Rail, Triple E	270-271
Erosion Cloth	67
E-Strap	HW
Etrier	WEB
Even Image Projection Screen	236
Event & Display Fabrics	82
Event Carpet, Dance & Expo Floor	252-264
Event Décor	180-185
Exhibit Roll Drum	299
Exhibit Vertical Lift	303
Exhibition Floor	254, 261
Expanding Batten Splice	HW
Expendables, Film & Video	348-349
Expo & Outdoor Fabric	130-132
Expo Gloss™ Floor	255, 261
Expo, Dance Floor & Event Carpet	252-264
Expo™ Floor	252, 261
Extenda	75
Extra Wide Burlap	67
Extra Wide Canvas	53, 243
Extra Wide Muslin	50, 56, 243
Extra Wide Muslin, Custom Dyed	50, 56
Extra Wide Tight Weave Muslin	57, 243
<b>F</b>	
Fabric Clips	214
Fabric Sample Binder	138
Fabrics	26-139
Fabrics, Projection	79-81, 234-235, 243
Fake Brick Paper	315
Fall Arrest Lanyards	WEB
Fasteners, Drape to Pipe	343
Faux Finishing Tools	330
Faux Painted Grass	313
Felt, Display	102
FF-2, FF-3, FF4 Powdered	334
Flame Retardants	333
FF-4, FF-6 Liquid	333
Fiber Rope	HW
Fiberglass Heat Border	158
Filled Scrim	50, 58, 61
Filled Steel Shot Bag	HW
Film & Video Sandbag, Filled or Unfilled	219, 348
Film & Video Supplies	344-349
Film & Video Swatch Book	WEB
Fine Gauze	66, 121
Finishes, Decorative	328-329
Fire Curtains	158
Fire Effects	315
Firecracker	111
Firesist, Sunbrella	131
Fitch Brushes	330
Flag Bunting Fans	132
Flakes, Scattered	WEB
Flame Retardancy Info, Chart	139
Flame Retardants	332-335
Flamex	333
Flat Cover	54-57
Flat Wall	185
Flat Washer	WEB
Flex Glue	326
Flexbond, Rosco	326
Flexcoat, Rosco	327
Flex-I-Trac ADC 132 Series	285
Flock Tape	WEB
Floor Cleaners	260
Floor Comparison Chart	261
Floor Lock	HW
Floor Plate	HW
Floor Storage Cart	260
Flooring	250-265
Floral Flash	179
Floretta Sprayer	331
Flow Release, Screen Goo	WEB
Fluorescent Paint, Rosco	322
Fluorescent Rain Curtains, Vinyl	177
Fluorescent Tape	336

Flurry Stretch Shapes	186
Foam Brushes	330
Foam, Acoustical	137
Foamcoat, Rosco	327
Focus Tools	HW
Foil Embossed Fabrics	WEB
Folding Easel	WEB
Footape Foot Loop	WEB
Fork	HW
Frame Components	249
Framing & Rail Fittings	HW
Frazzle	117
Friction Tape	338
Fringe & Trim	154-157
Fringe Curtain	170-173
Front Projection	238-239
Frosty Stretch Shapes	186
Full Grid & Silk, Film & Video	347
Fullness, Curtain	148-149



# Index

Product	Page #
Mirror Ball.....	316, 317
Mirror Ball Rotator.....	297
Mirror Floor, Vinyl.....	255, 261
Mirror, Glassless.....	306-307
Mirror, Molding Cloth.....	313
Mirror, Silver Shrink.....	314
Mirror Spheres.....	316
Mixol Tints.....	328
Molding Cloth.....	313
Molding Cloth Bark.....	313
Molding Cloth Grass.....	313
Molding Cloth Metallic.....	313
Molding Cloth Stone.....	313
Mongo-Wrench, Light Source.....	HW
Monk's Cloth.....	52
Motors, Drapery, Triple E.....	278
Mounting Bracket.....	287
Movie Screens, see Projection.....	230
Mule Blocks.....	HW
Multi Sizzle.....	112
Multiline II.....	HW
Multi-Purpose Fasteners.....	343
Muslin.....	54-57, 348
Muslin, Custom Dyed Extra Wide.....	50, 56
Muslin, Extra Wide IFR.....	57
Muslin, Poly.....	126, 349
Muslin, Trevira.....	56

**N**

Napkin Tassels.....	154-157
Natural Masking Tape.....	336
Natural Silk.....	97
Nebula™ Net.....	235
Neoprene Rubber Casters.....	HW
Netting & Gauze.....	63-66
Netting, Camo.....	315
Netting, Scenery.....	59, 64
New England Ropes.....	HW
NFG Tape.....	218, 336
NFR Silent Grid.....	347
Nicopress.....	HW
No Spin Square Plate Washer.....	WEB
Noise Reduction, Fabrics.....	134-137
Non-PPE (Utility) Gear.....	WEB
Nugget Lame.....	346
Nylon Cable Ties.....	343
Nylon, Rip Stop.....	131

**O**

Off Broadway Paint, Rosco.....	322
Omega Pacific.....	HW
One-Wrap Straps.....	343
Opaque Back Projection Screen.....	240
Opaque Velour.....	30-42
Opera Blue 140.....	236
Organdy.....	86
Organza.....	85
Orient.....	99
Outdoor & Expo Fabric.....	130-132
Oz Beam Clamps.....	HW

**P**

P-50 Sprayers.....	331
P-665 Tape.....	336, 337
Packing Blanket Scenery Covers.....	341
Packing Supplies.....	341
Packing Tape.....	338
Packing Wrap.....	341
Paint.....	320-324
Paint Additives, Flame Retardants.....	332
Paint Brushes.....	330
Paint Sampler Kits, Rosco.....	321-323
Paint Sprayers.....	331
Paint, Screen.....	244-245
Painter's Leno.....	61
Painter's Linen.....	52
Painter's Muslin.....	54-57, 348
Painter's Scrim.....	58, 61
Paladin.....	111
Pallet Master Caster.....	HW
Panel Lock.....	HW
Paper Confetti, FR.....	296, 314
Paper Snow, FR.....	296, 314
Paper Tape.....	336
Papers, Shop.....	340
Parallel Coupler.....	HW
Party Décor.....	164-181

Product	Page #
Party Knit.....	129
Passform, see Blackout Lining.....	45, 243
Pear Ring.....	HW
Penn Elcom Casters.....	HW
PepperScrim.....	235
Performance Floor, Rosco.....	256, 261
Permacel P-50 Double-Faced Tape.....	338
Permanent Roll Drum.....	299
Personal Protective Equipment.....	WEB
Photoscreen.....	347
Picture Hanging Hook & Socket.....	HW
Pin Hinges.....	HW
Pin Wire.....	HW
Pinch Pleats.....	149
Pinehurst.....	111
Pins, Blanket.....	342
Pipe & Base 1.0.....	216-217
Pipe & Base 2.0.....	212-215, 228
Pipe & Base Accessories.....	214
Pipe & Base Covers.....	187
Pipe & Base.....	208-217
Pipe & Base Storage.....	218
Pipe & Grommet Curtains.....	149-150
Pipe & Tube Clamps.....	HW
Pipe & Tube Hardware.....	HW
Pipe Bending.....	289
Pipe Clamps, Strut.....	HW
Pipe Crown, Pipe & Base 2.0.....	211
Pipe Pocket Finish.....	152, 237
Pipe Snap Clamp.....	343
Plasma Universal Mount, The Light Source.....	HW
Plaster, Kolcaustico.....	328
Plastic Glitter.....	329
Plastic Snow, FR.....	296, 314
Plastic Varnish.....	327
Plate Pick.....	HW
Pleats, Drapery.....	148-149
Pneumatic Lift Caster.....	HW
Podgers.....	HW
Poly Chintz.....	127
Poly Cyc.....	128
Poly Knit.....	126
Poly Muslin.....	126, 349
Poly Premier.....	45, 127
Poly Pro Fabric & Tape.....	349
Poly Pro Webbing.....	342
Poly Sheen.....	108
Poly Sheeting.....	340
Poly Silk.....	95, 347
Poly Stretch.....	75
Polyanna.....	45, 97
Polysilk Plus.....	WEB
Polyvel.....	41
Pounce Wheel.....	329
Powdered Flame Retardant.....	334
Precision Cut Fabrics.....	164-165
Premier Primer 2.0, Screen Goo.....	245
Premiere Clear, Rosco.....	327
Premiere String Curtains.....	173
Prestige Velour.....	30, 50, 135
Preval Sprayer.....	331
Primers, Adhesives & Coatings.....	326-327
Princess Velour.....	43, 51
Printed Fabric by the yard.....	92, 194
Printhead Studio.....	190-199
Printing, Digital.....	188-199
Pro Gaffer's Tape.....	336, 348
Pro Sheen Tape.....	338
Proclean NS Cleanser.....	260
Prod Supplies/Sewing Supplies.....	342-343
Prod Supplies/Shop Supplies.....	340-341
Production Swatch Book.....	139
Project Management, Stage Rigging.....	290-291
Projection Fabrics.....	79-81, 234-235, 243
Projection Materials.....	232-249
Projection Mesh.....	76
Projection Netting.....	235
Projection Point.....	245
Projection Screen, Extra Wide.....	240
Projection Scrim.....	235
Projection Surfaces.....	234-243
Proof Coil Chain.....	HW
Prop Gift Wrap.....	313, 315
Prop Lift.....	303
Prop Tree Bark.....	313

**Q**

Quarter Grid Fabric, Film & Video.....	347
Quarter Stop Silk, Film & Video.....	347
Quattro Tile Series.....	183
Quilted Packing Wrap.....	341

**R**

Räder Busch.....	HW
Radiance.....	109, 243
Rags, Box-O.....	329
Rail & Framing Fittings.....	HW
Rain Curtains & Designer Vinyl.....	176-179
Ranger Lining.....	45
Rappel Gloves.....	WEB
Ratchet Podgers.....	HW
Ratchet Strap Extender.....	HW
Ratchet Straps.....	HW
Rated Quick Links.....	HW
RB Cloth.....	45, 128, 349
Rear Projection.....	236-237
Rear Projection Coat, Screen Goo.....	244-245
Rear Projection Coating, Screen Goo.....	245
Rectangle Stretch Shapes.....	184
Red Carpet Runners.....	265
Red Velvet Ribbon.....	313, 315
Reference White Coat, Screen Goo.....	245
Reflective Fabric.....	83, 117
Reflectors, Bounces.....	343
Rental Department.....	220-229
Rental Event Drapes.....	224-225
Rental Masking.....	222
Replacement Spindle, Track.....	HW
Repp, Nassau Chevron.....	WEB
Resin, Aqua.....	327
Retail Display Roller.....	299
Retractable Tool Lanyard.....	HW
Reversible Dance Floor, Rosco.....	256, 261
Rhapsody.....	137
Ricochet.....	59, 64
Rigging Accessories.....	HW
Rigging Assembly Accessories.....	HW
Rigging Hardware, Scenic.....	HW
Rigging Ropes.....	HW
Rigging Supplies.....	HW
Right Angle Bracket Track.....	HW
Rig-I-Flex, ADC 140 Series Track.....	284
Rip Stop Nylon.....	131
Rip Stop Nylon Extra Wide, see Spinnaker.....	81
Ripplefold Curtains.....	149
Ripplefold Tape.....	343
Road Case.....	218
Robo Glue.....	326
Roll Drum Push Button Control.....	299
Roman Shade Curtain.....	147
Rope Clamps.....	WEB
Rope Cutter, Electric.....	HW
Rope Thimbles.....	HW
Rope Tools.....	340
Rope, Decorative.....	154-157
Rope, Designer.....	155-157
Rope, Fiber.....	HW
Rope, Splicing Kits.....	HW
Rope, Wire.....	HW
Rosco Adagio, Adagio Tour.....	256, 261
Rosco All Purpose Floor Cleaner.....	260
Rosco Clear Acrylic Coating.....	327
Rosco Crystal Gel.....	327
Rosco Flexbond.....	326
Rosco Flexcoat.....	327
Rosco Fluorescent Paint.....	322
Rosco Foamcoat Coating.....	327
Rosco Heavy-Duty Floor Cleaner.....	260
Rosco Iddings Deep Colors Paint.....	323
Rosco Off Broadway Paint.....	322
Rosco Paint Sampler Kits.....	321-323
Rosco Performance Floor.....	257, 261
Rosco Premiere Clear.....	327

Product	Page #
Rosco PVC Projection Screens.....	240
Rosco Reversible Dance Floor.....	256, 261
Rosco Show Floor.....	257, 261
Rosco Slit Drape.....	178
Rosco Studio Floor.....	257, 261
Rosco Supersaturated Bases.....	321
Rosco Supersaturated Paint.....	321
Rosco Supersaturated Paint Test Kit.....	321
Rosco Tough Prime.....	326
Rosco VividFX Paint.....	323
Roscotile Flooring.....	258, 261
Rose Brand Framing System, SpanFrame™.....	304-305
Rose Brand Glue.....	326
Rose Brand Kabuki.....	228, 294-295
Rose Brand Premium Projection 236-241.....	138
Rose Brand Sample Binder.....	138
Rose Brand Stretcher.....	248-249
Rose Brand Touch Panel Controller.....	279
Rota Pipe Lock.....	HW
Roto Casters.....	HW
Round Sling.....	HW
Royale Velour.....	29, 49, 50, 135
Rubber Casters.....	HW
Runway Floor.....	252, 261
Rustica.....	121

**S**

Saddle Bag.....	HW
Saddlebag Box.....	218
Safety Hook.....	WEB
Safety Tape.....	338
Safety/Rescue Rope.....	HW
Sail Cloth.....	81, 132, 347
Sample Binder.....	138
Sample Cards.....	138
Sand Bags.....	219
Sash Cord.....	347
Sateen Substitute, see Poly Chintz.....	127
Sateen, White Blackout.....	80
Satin Fabrics.....	102-111
Sausage Weight Bag.....	HW
Scaffold Anchor.....	WEB
Scenery Covers.....	341
Scenery Hardware.....	HW
Scenery Netting.....	59, 64
Scenery Props.....	308-317
Scenery Rotator.....	297
Scenic & Shop Supplies.....	340-343
Scenic Fabrics.....	52
Scenic Paints.....	320-324
Scenic Rigging Hardware.....	HW
Screen Goo 2.0.....	244-245
Screen Goo Kits.....	75, 349
Screen Goo Projection.....	244-245
Screen Scrim™.....	235
Screens.....	236-241
Scrim, Sharkstooth.....	60-61
Sculpt or Coat.....	50, 58, 60, 243, 347
Sea Sponge.....	329
Seamless Paper, Brick Pattern.....	315
SEG Framing.....	195
Semi-Gloss Rain Curtains, Vinyl.....	177
Semi-Wax Paper.....	342-343
Sequin Fabric.....	112
Sereno.....	91
Serge, Wool.....	46, 49, 135
Set Tape.....	338
Sewing Supplies/Prod Supplies.....	342-343
Sewing, Custom.....	142-157
Shackle.....	HW
Shackle Plate.....	HW
Shapes, Stretch.....	180-181
Sharkstooth Scrim.....	50, 58, 60, 243, 347
Sheave Blocks.....	HW
Sheer Fabrics.....	83-91
Sheeting, Poly.....	340
Shimmer Organza.....	85
Shimmer Scrim.....	116
Shimmer Voile.....	83, 243
Shimmerlite.....	116
Shindig Carpet.....	263
Shirring Fullness.....	149

Product	Page #
S-Hooks.....	151, 342
Shop & Production Supplies.....	320-343
Shop Papers.....	340
Shot Bag.....	218-219
Shoulder Eye Bolts.....	HW
Shoulder Mount, Pipe & Base 2.0.....	214
Show Floor, Rosco.....	257, 261
Show Taffeta Drapery.....	WEB
ShowLED Control.....	203
ShowLED Curtain.....	202-207
Showstopper.....	118
Shrink Mirror.....	314
Shurtape A&E.....	336, 337
Side Finishes, Curtains.....	151
Sidarm, Pipe & Base 2.0.....	214
Sign Base.....	WEB
Sign Hooks.....	WEB
Silent Sail Cloth.....	347
Silent Steel, ADC 280 Track.....	280-281
Silk Fabrics.....	95-101
Silks, Video.....	347
Silver Shimmer Voile.....	83
Tints, Mixol.....	314
Single MagMover.....	186
Single Pulley.....	HW
Single Wheel Casters.....	HW
Six Point / Three Thread Scrim.....	58, 61
Six Step Etriers.....	WEB
Sizzle.....	112
Skulls, Vacuum.....	310
Sling.....	HW
Slip Nomor 2000C.....	260
Slit Drape, Rosco.....	178
Small Diameter Rope Clamps/Descenders.....	WEB
Small Hardware Box, Pipe & Base.....	218
Small Scenery Motor.....	303
Smoke Out.....	130
Snap Hook.....	151
Snapshot.....	347
Snow.....	296, 314
Snow Blanket.....	314
Snow Machine, Tumbler.....	296
Snow, Molding Cloth.....	313
Snowflakes Stretch Shapes.....	186
SnowStar Tumbler.....	228, 296
Socket Clip, Versatop.....	214
Socket, Hanging.....	HW
Softfloor, SoftCarpet.....	WEB
SoftScreen.....	78, 243
Solid Braid Utility Rope.....	HW
Sonex.....	137
Sonic Stretch.....	75
Sonostop.....	137
Sound Absorption.....	134-137
Spandex.....	75, 349
Spandex, Keying.....	349
SpanFrame™.....	304-305
Spangle Curtain.....	178
Spanset.....	HW
Spark Chalk Bag.....	HW
Sparkle Tendo.....	75, 181
Sparkler.....	113
Speaker Cloth.....	65
Special Effects.....	310-317
Special Event Floor.....	252, 261
Specialty Tape.....	338
Specifine ADC 113 Series Track.....	285
Speed Clips.....	340
Spheres, Clear Plastic.....	WEB
Spike Tape.....	336
Spindle, Track.....	HW
Spinnaker.....	81, 347
Splats, Stretch Shapes.....	180-181
Splatters, Stretch Shapes.....	WEB
Splicing Kit.....	HW
Split Lock Washer.....	WEB
Sponge, Sea.....	329
Sprayers.....	331
Spring Clamps.....	343
Sprinkle Stretch Shape.....	186
Sputnik.....	HW
Square Gauze.....	59, 64, 243
Square Plate Washer.....	WEB
Stage Curtain Information.....	146-147
Stage Curtain Types.....	146-147
Stage Equipment, FXs & Mirrors.....	292-307

**T**

Tab Curtain.....	146
Tab Panel Lock.....	HW
Taffeta.....	108
Tape.....	336-338
Tape by the Case.....	337
Tape, Lead.....	342
Tassels.....	155-157
Tassels, Trim & Fringe.....	154-157
TC Clamp.....	HW
Teatro™ Floor.....	253, 261
Tendo.....	75, 181, 349
Tensioned Shapes.....	180-181
Tent Liner.....	126
Tergalet.....	98, 243
Textilene.....	59, 64, 77, 130, 243, 347
Textured & Matte Fabric.....	124-129
T-Handle Allen Wrench.....	HW

Product	Page #
Stage Floor.....	252-258
Stage Plug.....	HW
Stage Props.....	314-317
Stage Screw.....	HW
Stage Set X.....	HW
Stage Track.....	268
Stagemaster Casters.....	HW
Stanchion Top With Pin.....	214
Standard Muslin.....	50, 54, 348
Standard String Curtain.....	171
Standard Uprights.....	217
Star Drop Controller.....	203
Star Drops.....	200-207
Star Series, Stretch.....	WEB
Starmaze Laser Projector.....	WEB
Sta-Set.....	WEB
Static Brake Caster.....	HW
Steel Channel, Strut.....	HW
Steel Ribbon Weights.....	342
Steel Shot Bag.....	219
Stem Caster Sockets.....	HW
Stone Wall Panels, Vacuum.....	310
Storage Bags.....	341
Storage, Pipe & Base.....	218
Straight Lift Curtain.....	146-147
Street Shoe Floor Finish.....	260, 327
Stretch Fabrics.....	74-75
Stretch Loop.....	342
Stretch Netting.....	74
Stretch Shapes.....	180-181
Stretch Walls.....	183
Stretcher Frames.....	248-249
Stretch-Resistant Sash Cord.....	HW
String Curtains.....	170-173
Striped Cable Path Tape.....	338
Strut Beam Clamps.....	HW
Strut Channel Fasteners.....	HW
Strut Channel Framing Fittings.....	HW
Strut Channels & Accessories.....	HW
Strut Clamps.....	HW
Strut Nuts.....	HW
Strut Pipe Clamps.....	HW
Studio Accessories.....	329
Studio Floor, Rosco.....	257, 261
Studio Roller.....	299
Studio Track.....	



## Staff / Ordering Information and Terms & Conditions

### STAFF

\*Habla Español

<b>Ext.</b>	<b>East Coast Sales - Ext. 355</b>	<b>@RoseBrand.com</b>
138	Brandi Vold	brandi.vold
168	Brendalee Gonzalez*	brendalee.gonzalez
158	Brian Grabowski	brian.grabowski
139	Eyan Gottlieb	eyan.gottlieb
108	George Jacobstein	george.jacobstein
210	Greg Schaefer	greg.schaefer
130	Jennifer Perez*	jennifer.perez
140	John Nicastro	john.nicastro
274	Joshua Alemany	joshua.alemany
296	Josh Jacobstein	josh.jacobstein
118	Lisa Coulouris*	lisa.coulouris
202	Mary Katherine Vandiver	mk.vandiver
161	Matt Biringer	matt.biringer
163	Onis McHenry	onis.mchenry
112	Peter Finder	peter.finder
101	Renee Vero	renee.vero
125	Roger Claman	roger.claman
110	Stella Gomez*	stella.gomez
124	Tom Coulouris	tom.coulouris
243	Tom Sullivan	tom.sullivan
	<b>East Coast Rentals - Ext. 350</b>	<b>@RoseBrand.com</b>
191	Betty Villanueva	betty.villanueva
172	Carlene Carty	carlene.carty
216	Jennifer Luna	jennifer.luna
171	Michael Johansen	michael.johansen
135	Zoe Paine	zoe.paine
	<b>East Coast Customer Service - Ext. 352</b>	<b>@RoseBrand.com</b>
131	Brenda Gonzalez*	brenda.gonzalez
213	Maria Francis*	maria.francis
137	Nicole Greene	nicole.greene
	<b>CA Sales - Ext. 355</b>	<b>@RoseBrand.com</b>
416	Blanca Vargas*	blanca.vargas
439	Carrie Johns	carrie.johns
465	Corey Womack	corey.womack
427	Doug Harvey	doug.harvey
454	Jeff Flowers	jeff.flowers
451	Jeri-Dawn Youngblood	jd.youngblood
426	Mariana Slutzky*	mariana.slutzky
482	Sasha Venola	sasha.venola
415	Tina C. Wright	tina.wright
467	Tonie Fiorito	tonie.fiorito
443	Zach Tysinger	zach.tysinger
	<b>CA Rentals - Ext. 350</b>	<b>@RoseBrand.com</b>
435	Ed Lennon	ed.lennon
434	Sean Finley	sean.finley
	<b>CA Customer Service - Ext. 352</b>	<b>@RoseBrand.com</b>
464	Daisy Estrada*	daisy.estrada
455	Greg Valencia	greg.valencia
	<b>Canadian Sales</b>	<b>@RoseBrand.com</b>
175	Colin Sangster	colin.sangster
175	Tony Devai	tony.devai
175	Rhonda Holmes	rhonda.holmes
	<b>Printhead Studio - Ext. 354</b>	<b>@PrintheadStudio.com</b>
242	Adam Walker	adam.walker
194	Ernesto Gomez*	ernesto.gomez
211	Jason Tibbetts	jason.tibbetts
484	Megan Ribeiro*	megan.ribeiro
229	Mike All	mike.all
128	Mike Reed	michael.reed
155	Molly Block	molly.block
	<b>Technical Project Management</b>	<b>@RoseBrand.com</b>
483	Angela Millwood	angela.millwood
318	Bob Casey	bob.casey
466	Chris Poyourow	chris.poyourow
149	Dan Browder	dan.browder
146	Jesse Adams	jesse.adams
441	Kevin Twomey	kevin.twomey
173	Mark O'Brien	mark.obrien
241	Mike Cucciarre	mike.cucciarre
	<b>Flame Retardant Certificates - Ext. 268</b>	<b>@RoseBrand.com</b>
134	Mercedes Betances*	mercedes.betances
137	Nicole Greene	nicole.greene

### FOR COMPLETE DETAILS VISIT [RoseBrand.com](http://RoseBrand.com)

Warehouse Hours - 8:15 am - 5:00 pm. Warehouse breaks 12:15 - 1:00 pm for lunch.

#### Ordering

- We may change prices, specifications, or discontinue any item without notice.
- You may place orders by phone, fax, e-mail, postal mail, or internet, subject to confirmation from us.
- We can ship in-stock items the same day, for orders placed before 1 p.m.
- All prices are FOB ship point.
- Most, but not all, items are stocked in both warehouses.
- Cut fabric orders (less than full roll) will be cut to the nearest full yard.
- When purchasing a full roll or more of stock or custom material, up to a 10% overage is allowed.

#### Custom/Special Orders

- Please plan ahead. Some items featured in our catalog are available by special order only or are made-to-order.
- Custom orders require credit card, non-refundable deposit.

#### Payment



- We accept all major credit cards.
- When using debit cards, please tell your salesperson at the time of purchase so to avoid your bank freezing more than your purchase amount.
- We charge your card with final charges only at the time of shipment.
- Will-call and delivery orders are prepared only with the guarantee of a credit card.
- Institutional purchase orders may be accepted by fax, postal mail, or email attachment.
- We accept company checks, but not personal checks.
- Returned company checks will incur a \$25 bank and processing fee.
- Net 30 accounts may be established prior to shipping by submitting bank and trade references by fax or mail for review.
- The number of states that require assessment of sales tax grows each year. If required, sales (use) tax will be assessed, unless you have registered your tax exempt/resale certificate via our Avalara Tax Portal. Call or email TaxExemptCerts@RoseBrand.com for details.
- We are unable to ship C.O.D.

#### Shipping

- Please specify your carrier of choice and level of service when you order.
- Most packages ship UPS, unless specified.
- Prepaid freight charges will be added to your invoice.
- A handling surcharge fee is added to all shipments.
- When you request that we choose a freight carrier, we will try to find the least expensive carrier that can reliably deliver your shipment.
- We cannot be held responsible for the performance of any shipper, whether our choice or yours.
- The customer has the responsibility to inspect each shipment; they must sign for a shipment as damaged in order for freight claims to be filed.
- Standard shipper's insurance for the replacement value of each shipment is added to freight charges.

#### Returns

- All orders must be opened and inspected within 5 days of receipt.
- Report any discrepancy with your order within 30 days of receiving your order.
- No returns on cut merchandise, special orders, custom fabrications, remnants or closeouts.
- Returnable (unused and unaltered) goods incur a 25% restocking charge.
- Only pre-authorized returns will be accepted. Please call customer service to obtain the Return Material Authorization number (RMA #) needed before making a return shipment.
- Defective products may be replaced or repaired, at our discretion.
- Defective products must be returned within 30 days of shipping.
- All will-call orders must be picked up within 30 days.
- Rose Brand guarantees that the textile products specified are not misbranded nor falsely or deceptively advertised or invoiced under the provisions of the Textile Identification Act.

Florida's leading event and decor company is now a member of the Rose Brand family.

*Swag* DECOR®  
a Rose Brand company



Swag Decor provides picture perfect drape and decor, as well as expert design collaboration and full service delivery, setup and strike. Specializing in social and corporate events, Swag Decor is your go to source for events in Florida and a member of the Rose Brand family of companies.







PO Box 1536  
Secaucus, NJ 07096-1536

800.223.1624  
800.360.5056  
RoseBrand.com

Cover Photo: Products: Rain Curtains; Custom Curved Track and Installation Services; *The Let Go* by Nick Cave at Park Avenue Armory, June 2018; Director of Production: Paul King; Photo by James Prinz Photography. Courtesy of the artist and Jack Shainman Gallery, New York.

Back Photo: Products: Prestige Velour, Avora Lining, Antique Gold Design Weight Bullion Fringe, Custom Applique; Sandusky State Theatre; Photo: Rob Turner

## CURTAINS, FABRICS AND PRODUCTION SUPPLIES FOR

THEATRE  
EVENTS/PARTIES  
SCHOOLS/UNIVERSITIES  
SCENE SHOPS  
HOUSES OF WORSHIP  
TOURING PRODUCTIONS  
FILM & VIDEO  
THEME PARKS  
MUSEUMS  
TRADE SHOWS  
SPORTS VENUES  
EXHIBITS  
ARCHITECTURAL ENVIRONMENTS  
CONCERTS  
VISUAL MERCHANDISING  
DANCE  
HAUNTED HOUSES  
ART INSTALLATIONS

STAGE CURTAINS/BACKDROPS  
FABRICS  
RENTALS CURTAINS  
DIGITAL PRINTING  
LED STAR DROPS  
PROJECTION SURFACES  
STAGE HARDWARE & RIGGING  
GAFFERS, SPIKE & GLOW TAPE  
SCENIC PAINT & FLAME RETARDANTS  
DMX WINCHES & ROLL DROPS  
CURTAIN TRACK  
PIPE & BASE  
DANCE FLOOR/EVENT CARPET  
PRODUCTION SUPPLIES  
FLOORING  
RENTAL CURTAINS

